

## 阅读申明

- 1.本站收集的数据手册和产品资料都来自互联网，版权归原作者所有。如读者和版权方有任何异议请及时告之，我们将妥善解决。
- 2.本站提供的中文数据手册是英文数据手册的中文翻译，其目的是协助用户阅读，该译文无法自动跟随原稿更新，同时也可能存在翻译上的不当。建议读者以英文原稿为参考以便获得更精准的信息。
- 3.本站提供的产品资料，来自厂商的技术支持或者使用者的心得体会等，其内容可能存在描述上的差异，建议读者做出适当判断。
- 4.如需与我们联系，请发邮件到marketing@iczoom.com，主题请标有“数据手册”字样。

## Read Statement

1. The datasheets and other product information on the site are all from network reference or other public materials, and the copyright belongs to the original author and original published source. If readers and copyright owners have any objections, please contact us and we will deal with it in a timely manner.
2. The Chinese datasheets provided on the website is a Chinese translation of the English datasheets. Its purpose is for reader's learning exchange only and do not involve commercial purposes. The translation cannot be automatically updated with the original manuscript, and there may also be improper translations. Readers are advised to use the English manuscript as a reference for more accurate information.
3. All product information provided on the website refer to solutions from manufacturers' technical support or users the contents may have differences in description, and readers are advised to take the original article as the standard.
4. If you have any questions, please contact us at marketing@iczoom.com and mark the subject with "Datasheets" .

# Common Mode Choke Coils(Line Filters) for AC Power Supply

## Compact and Separable Bobbin Type UF Series

Conformity to RoHS Directive

TDK common mode choke coils(line filters) are used in a wide range of prevention of electromagnetic interference(EMI) and radio frequency interference(RFI) from power supply lines and for prevention of multifunctioning of products such as measuring equipment and system equipment.

### FEATURES

- Wide range of selection.
- High impedance at applicable frequency.
- High self-resonant frequency.

### PRODUCT IDENTIFICATION

UF □□□□ V - A □□□Y □R□ - 01  
 (1) (2) (3) (4) (5) (6) (7)

- (1) Core shape  
UF: U-type core
- (2) Dimensional code  
Length×Height
- (3) External shape code  
V: Vertical type H: Horizontal type
- (4) High  $\mu$  material
- (5) Inductance value  
Example) 133:13mH
- (6) Rated current value  
Example) 3R0:3.0A
- (7) Product management number

### SELECTION CHART

Series	Configuration	Type	Inductance value min.	Rated current (A)	Handling power* $L \times I^2$ (mH×A <sup>2</sup> )	Weight (g)typ.	Minimum package quantity (pieces/box)
UF	Two sections bobbin types	UF1717V	0.2 to 10mH	0.25 to 1.6	0.6	3.5	640
		UF1717H	0.2 to 10mH	0.25 to 1.6	0.6	3.5	480
	Two sections bobbin types (For high frequency)	UF1717V	10 to 60 $\mu$ H	1 to 3	0.08	3	640
		UF1815SG	50 to 350 $\mu$ H	1 to 5	1.2	4.6	1280

\* Handling power=(Inductance value)×(Current)<sup>2</sup>. It is possible to design within the range below this value.  
 [Example] The coil for 2A can make even the inductance of 2.5mH or less a product for handling power 10.

• Conformity to RoHS Directive: This means that, in conformity with EU Directive 2002/95/EC, lead, cadmium, mercury, hexavalent chromium, and specific bromine-based flame retardants, PBB and PBDE, have not been used, except for exempted applications.

• All specifications are subject to change without notice.

## Two Sections Bobbin Type UF Series

### FEATURES

- This series is compact in size due to its use of high permeability ferrite core.

### UF1717V/UF1717H(2 SEPARABLE BOBBIN) TYPES SHAPES AND DIMENSIONS/CIRCUIT DIAGRAM

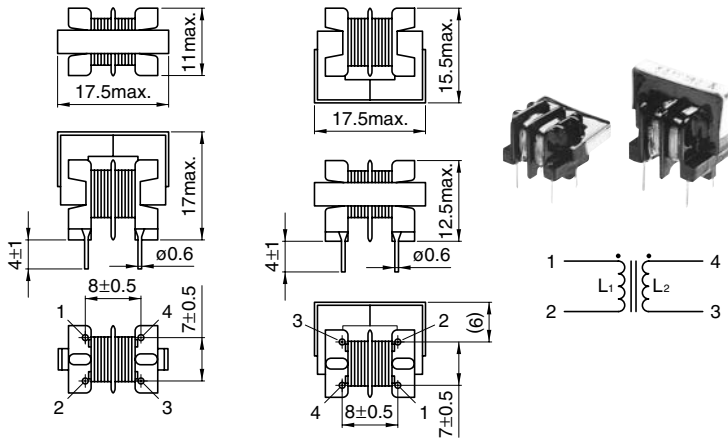

Weight: 3.5g typ.

Recommended hole diameter:  $\phi 1.1$   
Dimensions in mm

### TYPICAL ELECTRICAL CHARACTERISTICS IMPEDANCE vs. FREQUENCY CHARACTERISTICS

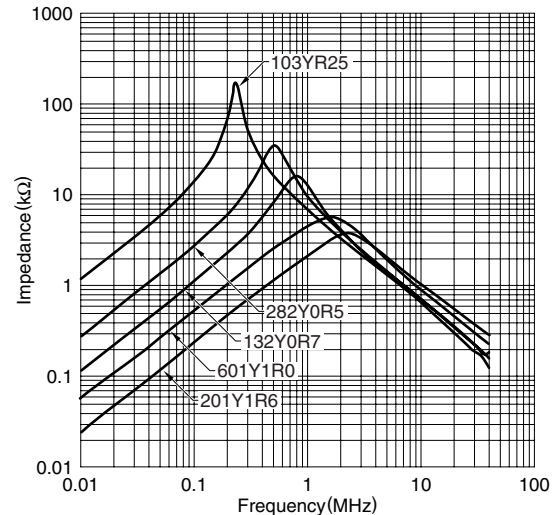

### ELECTRICAL CHARACTERISTICS (STANDARD LINE UP)

Part No.	Inductance (mH)min.	DC resistance ( $\Omega$ )max.	Rated current Iac(A)max.
UF1717V-103YR25-02	10	3.5	0.25
UF1717V-702Y0R3-01	7	2.5	0.3
UF1717V-342Y0R4-01	3.4	1.3	0.4
UF1717V-282Y0R5-01	2.8	1	0.5
UF1717V-152Y0R6-01	1.5	0.55	0.6
UF1717V-132Y0R7-01	1.3	0.5	0.7
UF1717V-601Y1R0-01	0.6	0.2	1
UF1717V-201Y1R6-01	0.2	0.1	1.6
UF1717H-103YR25-01	10	3.5	0.25
UF1717H-702Y0R3-01	7	2.5	0.3
UF1717H-342Y0R4-01	3.4	1.3	0.4
UF1717H-282Y0R5-01	2.8	1	0.5
UF1717H-152Y0R6-01	1.5	0.55	0.6
UF1717H-132Y0R7-01	1.3	0.5	0.7
UF1717H-601Y1R0-01	0.6	0.2	1
UF1717H-201Y1R6-01	0.2	0.1	1.6

- Measuring equipment of inductance value:  
LCR meter(HP4261A, HP4263B or equivalent)[f=1kHz]

### PACKAGING QUANTITIES

UF1717V	640pieces/box
UF1717H	480pieces/box

### RATINGS

Item	Standard value	Conditions
Rated voltage(V)	80 to 280	50Hz/60Hz
Dielectric withstanding voltage(V)	2000	Between each winding for 1 minute
Insulation resistance (M $\Omega$ )	100min.	Between each winding for DC.500V
Temperature rise( $^{\circ}$ C)	45max.	With line resistance
Operating temperature range( $^{\circ}$ C)	-20 to +120	Including self-temperature rise
Storage temperature range( $^{\circ}$ C)	-20 to +85	
Resistance to soldering temperature*1	260 $\pm$ 5 $^{\circ}$ C, 10 $\pm$ 1sec	Solder bath method
	350 $\pm$ 5 $^{\circ}$ C, 5sec max.	Soldering iron method
Applicable safety standard*2	Electrical Appliance and Material Safety Law ("DENAN"), IEC60065, UL6500, CSA C22.2	

\*1 Pb free solder(Sn-3Ag-0.5Cu)

\*2 However, this product is not recognized by each regulations.

## Two Sections Bobbin Type(For High Frequency) UF Series

### FEATURES

- This series is designed to reduce stray capacity between windings by using a single-layer coil construction on Ni-Zn ferrite cores, which offer excellent high frequency characteristics.
- This series provides excellent noise suppression for high frequency ranges including the FM band.
- Since the windings are divided into two sections, this filter can also be used as a signal line with excellent withstanding voltage.

### UF1717V(2 SEPARABLE BOBBIN FOR HIGH FREQUENCY) TYPE SHAPES AND DIMENSIONS/CIRCUIT DIAGRAM

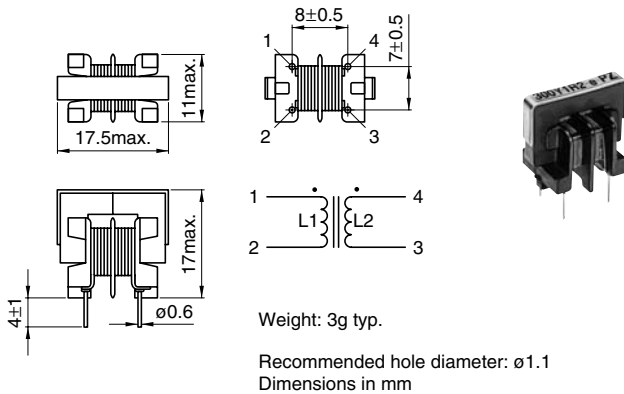

### TYPICAL ELECTRICAL CHARACTERISTICS IMPEDANCE vs. FREQUENCY CHARACTERISTICS

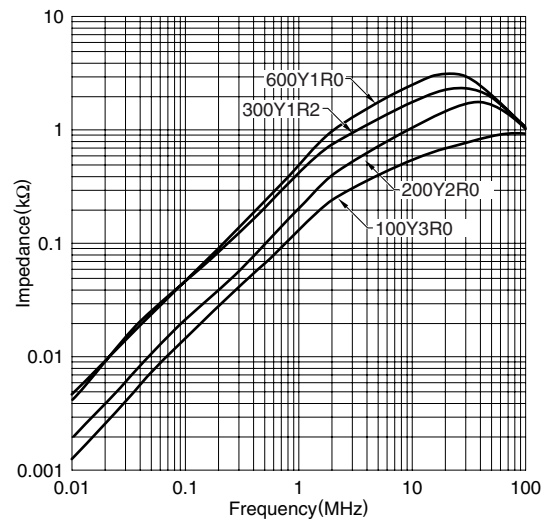

### ELECTRICAL CHARACTERISTICS (STANDARD LINE UP)

Part No.	Inductance ( $\mu$ H)min.	DC resistance ( $m\Omega$ )max.	Rated current Iac(A)max.
UF1717V-600Y1R0-03	60	300	1
UF1717V-300Y1R2-03	30	150	1.2
UF1717V-200Y2R0-03	20	100	2
UF1717V-100Y3R0-03	10	50	3

- Measuring equipment of inductance value:  
LCR meter(HP4261A, HP4263B or equivalent)[f=1kHz]

### PACKAGING QUANTITIES

UF1717V	640pieces/box
---------	---------------

### RATINGS

Item	Standard value	Conditions
Rated voltage(V)	80 to 280	50Hz/60Hz
Dielectric withstanding voltage(V)	2000	Between each winding for 1 minute
Insulation resistance ( $M\Omega$ )	100min.	Between each winding for DC.500V
Temperature rise( $^{\circ}$ C)	45max.	With line resistance
Operating temperature range( $^{\circ}$ C)	-20 to +120	Including self-temperature rise
Storage temperature range( $^{\circ}$ C)	-20 to +85	
Resistance to soldering temperature*1	260 $\pm$ 5 $^{\circ}$ C, 10 $\pm$ 1sec	Solder bath method
	350 $\pm$ 5 $^{\circ}$ C, 5sec max.	Soldering iron method
Applicable safety standard*2	Electrical Appliance and Material Safety Law ("DENAN"), IEC60065, UL6500, CSA C22.2	

\*1 Pb free solder(Sn-3Ag-0.5Cu)

\*2 However, this product is not recognized by each regulations.

## Two Sections Bobbin Type(For High Frequency) UF Series

### FEATURES

- This series uses a Mn-Zn ferrite core and yet it offers excellent noise suppression into the high frequencies due to its low distributed inductance construction based on a single layer winding.
- This compact filter's inductance has been improved by as much as 50% compared to existing products of comparable size while its high profile has been reduced by approximately 30%.

### UF1815SG(2 SEPARABLE BOBBIN FOR HIGH FREQUENCY) TYPE SHAPES AND DIMENSIONS/CIRCUIT DIAGRAM

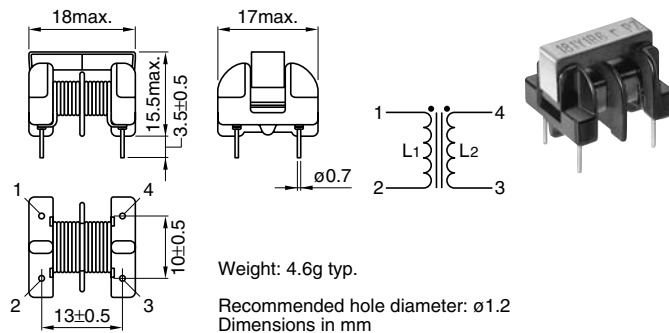

### TYPICAL ELECTRICAL CHARACTERISTICS IMPEDANCE vs. FREQUENCY CHARACTERISTICS

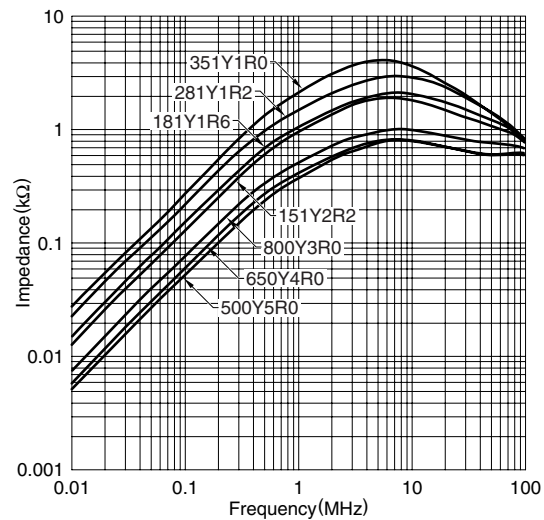

### ELECTRICAL CHARACTERISTICS (STANDARD LINE UP)

Part No.	Inductance ( $\mu$ H)min.	DC resistance (m $\Omega$ )max.	Rated current Iac(A)max.
UF1815SG-351Y1R0-01	350	300	1
UF1815SG-281Y1R2-01	280	250	1.2
UF1815SG-181Y1R6-01	180	130	1.6
UF1815SG-151Y2R2-01	150	100	2.2
UF1815SG-800Y3R0-01	80	50	3
UF1815SG-650Y4R0-01	65	30	4
UF1815SG-500Y5R0-01	50	25	5

- Measuring equipment of inductance value:  
LCR meter(HP4261A, HP4263B or equivalent)[f]=1kHz]

### PACKAGING QUANTITIES

UF1815SG	1280pieces/box
----------	----------------

### RATINGS

Item	Standard value	Conditions
Rated voltage(V)	80 to 280	50Hz/60Hz
Dielectric withstanding voltage(V)	2000	Between each winding for 1 minute
Insulation resistance (M $\Omega$ )	100min.	Between each winding for DC.500V
Temperature rise( $^{\circ}$ C)	45max.	With line resistance
Operating temperature range( $^{\circ}$ C)	-20 to +120	Including self-temperature rise
Storage temperature range( $^{\circ}$ C)	-20 to +85	
Resistance to soldering temperature*1	260 $\pm$ 5 $^{\circ}$ C, 10 $\pm$ 1sec	Solder bath method
Applicable safety standard*2	350 $\pm$ 5 $^{\circ}$ C, 5sec max.	Soldering iron method
	Law ("DENAN"), IEC60065, UL6500, CSA C22.2	

\*1 Pb free solder(Sn-3Ag-0.5Cu)

\*2 However, this product is not recognized by each regulations.