

阅读申明

- 1.本站收集的数据手册和产品资料都来自互联网，版权归原作者所有。如读者和版权方有任何异议请及时告之，我们将妥善解决。
- 2.本站提供的中文数据手册是英文数据手册的中文翻译，其目的是协助用户阅读，该译文无法自动跟随原稿更新，同时也可能存在翻译上的不当。建议读者以英文原稿为参考以便获得更精准的信息。
- 3.本站提供的产品资料，来自厂商的技术支持或者使用者的心得体会等，其内容可能存在描述上的差异，建议读者做出适当判断。
- 4.如需与我们联系，请发邮件到marketing@iczoom.com，主题请标有“数据手册”字样。

Read Statement

1. The datasheets and other product information on the site are all from network reference or other public materials, and the copyright belongs to the original author and original published source. If readers and copyright owners have any objections, please contact us and we will deal with it in a timely manner.
2. The Chinese datasheets provided on the website is a Chinese translation of the English datasheets. Its purpose is for reader's learning exchange only and do not involve commercial purposes. The translation cannot be automatically updated with the original manuscript, and there may also be improper translations. Readers are advised to use the English manuscript as a reference for more accurate information.
3. All product information provided on the website refer to solutions from manufacturers' technical support or users the contents may have differences in description, and readers are advised to take the original article as the standard.
4. If you have any questions, please contact us at marketing@iczoom.com and mark the subject with "Datasheets" .

Common Mode Filters

For general signal line/power line

ZJY series

Type: **ZJY51R5**

Issue date: September 2011

- All specifications are subject to change without notice.
 - Conformity to RoHS Directive: This means that, in conformity with EU Directive 2002/95/EC, lead, cadmium, mercury, hexavalent chromium, and specific bromine-based flame retardants, PBB and PBDE, have not been used, except for exempted applications.
-

Common Mode Filters

For General Signal Line / Power Line

Conformity to RoHS Directive

ZJY Series ZJY51R5

FEATURES

- A common mode filter for distortion-free removal of noise from transmitted signals. Best common mode filter for transmission of high quality signals.
- Best filter for countering the common mode noise resulting from data signal processing by PCs, phone equipment, etc.
- Highly appropriate for IC board mounting due to DIP type structure.
- Due to a maximum current tolerance of 2A, can also be used to counter power line noise.

APPLICATIONS

Personal computers, telephones, LANs, ISDNs, digital PBXs, electronic games, CTVs, CD-ROM drives, 8mm video equipment, and other electronic devices

PACKAGING STYLE AND QUANTITIES(Tube style)

Part No.	Quantity
ZJY51R5-2P-01	80 pieces
ZJY51R5-2PB-01	80 pieces
ZJY51R5-2PL-01	80 pieces
ZJY51R5-4P-01	40 pieces
ZJY51R5-M4PA-01	40 pieces
ZJY51R5-8PA-01	20 pieces

RECOMMENDED SOLDERING CONDITION

RECOMMENDED FLOW TEMPERATURE PROFILE FOR LEAD-FREE SOLDER

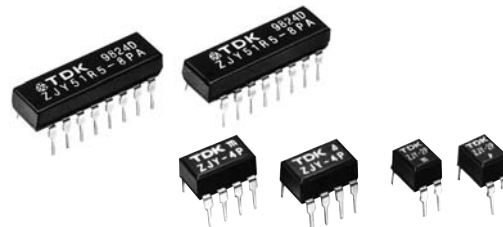
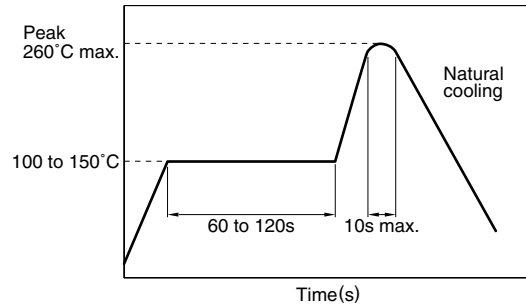

SHAPES AND DIMENSIONS

TRANSFER MOLD

ZJY51R5-2P-01, -2PB-01, -2PL-01

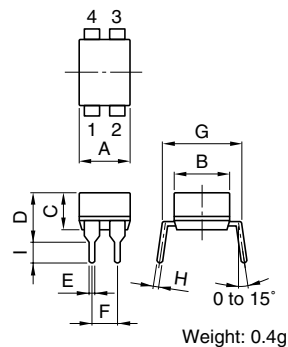

ZJY51R5-4P-01, -M4PA-01

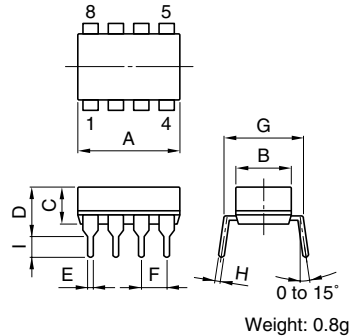

PLASTIC CASE

ZJY51R5-8PA-01

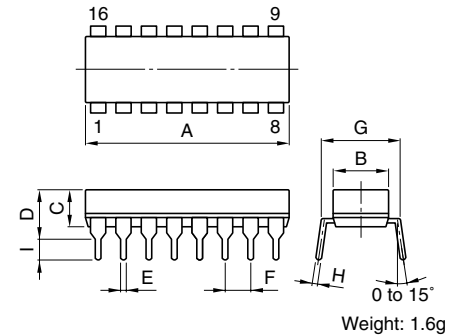

Part No.	Dimensions in mm									
	A max.	B max.	C max.	D max.	E	F±0.25	G	H	I	
ZJY51R5-2P-01, -2PB-01, -2PL-01*	5.5	6.86	4.57	5.84	0.5	2.54	7.62	0.25	2.54	
ZJY51R5-4P-01, -M4PA-01	10.5	6.86	4.57	5.84	0.5	2.54	7.62	0.25	2.54	
ZJY51R5-8PA-01	23.5	7	4.6	6.3	0.5	2.54	7.62	0.25	2.54	

* The ".01" designation at the end of the product code indicates Lead-free compatible product.

CIRCUIT DIAGRAMS

ZJY51R5-2P-01, -2PB-01, -2PL-01

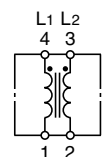

ZJY51R5-4P-01, -M4PA-01

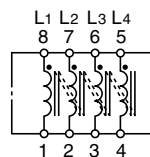

ZJY51R5-8PA-01

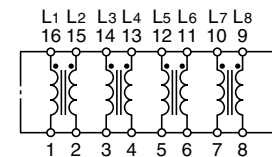

• Conformity to RoHS Directive: This means that, in conformity with EU Directive 2002/95/EC, lead, cadmium, mercury, hexavalent chromium, and specific bromine-based flame retardants, PBB and PBDE, have not been used, except for exempted applications.

• All specifications are subject to change without notice.

ELECTRICAL CHARACTERISTICS

Part No.	ZJY51R5-2P-01, -4P-01	ZJY51R5-2PB-01*1	ZJY51R5-2PL-01*2	ZJY51R5-M4PA-01	ZJY51R5-8PA-01
Rated voltage Edc(V)	50	50	50	50	50
Rated current (A)	2	2	2	0.5	0.5
Test voltage Edc(V) [Between terminals for 5s]	125	125	250	125	250
Insulation resistance (MΩ) [Between terminals at DC.50V for 1min]	100 min.	100 min.	100 min.	100 min.	100 min.
DC resistance (Ω) [Each line]	0.12 max.	0.12 max.	0.10 max.	0.25 max.	0.07 max.
Operating temperature range (°C)	-25 to +85	-25 to +85	-25 to +85	-25 to +85	-25 to +85
Storage temperature range(After mount)(°C)	-25 to +85	-25 to +85	-25 to +85	-25 to +85	-25 to +85
Impedance (Ω) [+5 to +35°C]	[20 to 300MHz]	[6 to 20MHz]	[20 to 100MHz]	[20 to 300MHz]	[20 to 300MHz]

*1 This type has improved low-range characteristics.

*2 This type is wrapped separately (for communication lines).

TYPICAL ELECTRICAL CHARACTERISTICS

IMPEDANCE CHARACTERISTICS (for 1 element)

ZJY51R5-2P-01, -4P-01, -8PA-01

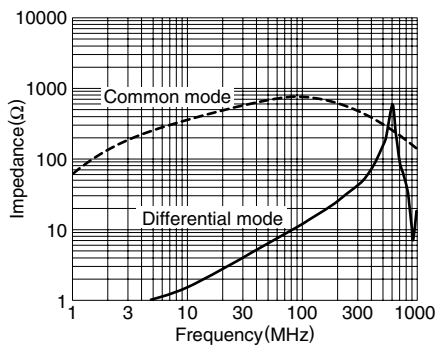

ZJY51R5-2PB-01

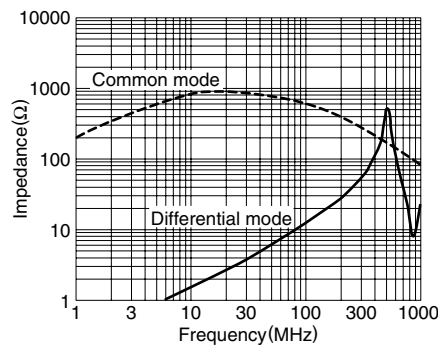

ZJY51R5-2PL-01

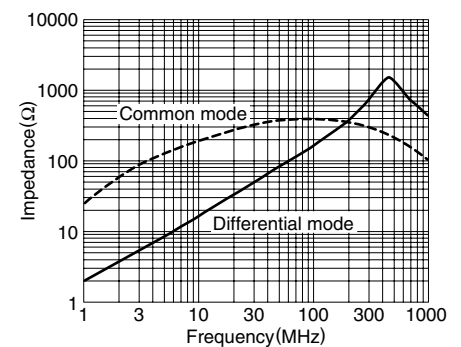

ZJY51R5-M4PA-01

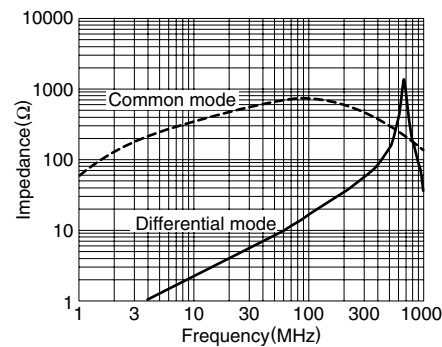

MEASURING CIRCUIT

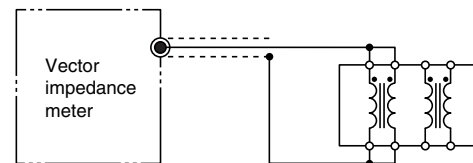

Vector impedance meter(YHP 4191A equivalent)
Measuring at each Common mode choke coil

TYPICAL APPLICATION

An application example showing how radiation noise is prevented when transmitter and receiver are connected via twisted pair cables.

