

阅读申明

- 1.本站收集的数据手册和产品资料都来自互联网，版权归原作者所有。如读者和版权方有任何异议请及时告之，我们将妥善解决。
- 2.本站提供的中文数据手册是英文数据手册的中文翻译，其目的是协助用户阅读，该译文无法自动跟随原稿更新，同时也可能存在翻译上的不当。建议读者以英文原稿为参考以便获得更精准的信息。
- 3.本站提供的产品资料，来自厂商的技术支持或者使用者的心得体会等，其内容可能存在描述上的差异，建议读者做出适当判断。
- 4.如需与我们联系，请发邮件到marketing@iczoom.com，主题请标有“数据手册”字样。

Read Statement

1. The datasheets and other product information on the site are all from network reference or other public materials, and the copyright belongs to the original author and original published source. If readers and copyright owners have any objections, please contact us and we will deal with it in a timely manner.
2. The Chinese datasheets provided on the website is a Chinese translation of the English datasheets. Its purpose is for reader's learning exchange only and do not involve commercial purposes. The translation cannot be automatically updated with the original manuscript, and there may also be improper translations. Readers are advised to use the English manuscript as a reference for more accurate information.
3. All product information provided on the website refer to solutions from manufacturers' technical support or users the contents may have differences in description, and readers are advised to take the original article as the standard.
4. If you have any questions, please contact us at marketing@iczoom.com and mark the subject with "Datasheets" .

MCR-SL-S-...00-U(I)-(LP)

Current Measuring Transducer for Sinusoidal and Non-Sinusoidal Alternating Currents



INTERFACE

Data Sheet

© PHOENIX CONTACT - 05/2006

Description

The **MCR-SL-S-...** current measuring transducers provide the user with the opportunity of retrofitting the current measuring transducer in an existing system without interruption. This is made possible by an open up coil that functions on the Rogowski principle. Insulated conductors on the primary side with a diameter of up to 18.5 mm can be embraced. The current measuring transducers are electrically isolated from one another on the input and output side.

The **MCR-SL-S-...-U** current measuring transducers convert sinusoidal and non-sinusoidal alternating currents up to 400 A into analog standard signals of 0...5 V or 0...10 V. The measuring ranges for input and output can be selected via a switch.

The **MCR-SL-S-...-I-LP** current measuring transducers convert sinusoidal and non-sinusoidal alternating currents up to 400 A into the analog standard signal of 4...20 mA. The measuring range at the output is set with a switch. On the output side, the current measuring transducers are operated in a 4...20 mA current loop, which simultaneously provides the power supply for the modules, which is necessary for signal conversion.

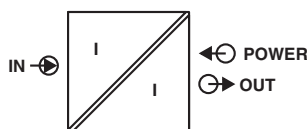
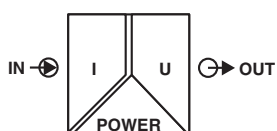

Make sure you always use the latest documentation.
It can be downloaded at www.download.phoenixcontact.com.
A conversion table is available on the Internet at
www.download.phoenixcontact.com/general/7000_en_00.pdf.



This data sheet is valid for all products listed on the following page:

Ordering Data

Description	Type	Order No.	Pcs./Pkt
MCR current measuring transducer, for measuring sinusoidal and non-sinusoidal alternating currents, input current 0...100 A, output voltage 0...(5) 10 V	MCR-SL-S-100-U	2813457	1
MCR current measuring transducer, for measuring sinusoidal and non-sinusoidal alternating currents, input current 0...200 A, output voltage 0...(5) 10 V	MCR-SL-S-200-U	2813460	1
MCR current measuring transducer, for measuring sinusoidal and non-sinusoidal alternating currents, input current 0...400 A, output voltage 0...(5) 10 V	MCR-SL-S-400-U	2813473	1
MCR current measuring transducer, for measuring sinusoidal and non-sinusoidal alternating currents, input current 0...100 A, loop-powered output with 4...20 mA	MCR-SL-S-100-I-LP	2813486	1
MCR current measuring transducer, for measuring sinusoidal and non-sinusoidal alternating currents, input current 0...200 A, loop-powered output with 4...20 mA	MCR-SL-S-200-I-LP	2813499	1
MCR current measuring transducer, for measuring sinusoidal and non-sinusoidal alternating currents, input current 0...400 A, loop-powered output with 4...20 mA	MCR-SL-S-400-I-LP	2813509	1

Technical Data

General Data	MCR-SL-S-...-U	MCR-SL-S-...-I-LP	
Supply voltage	20 V DC ... 30 V DC		
Current consumption	< 30 mA	-	
Transmission error	< ±1% of end value		
Cable position error	< 0.63%		
Temperature coefficient	< 0.035%/K	< 0.025%/K	
Step response (10% ... 90%)	< 340 ms		
Degree of protection	IP20		
Test voltage	5 kV, 50 Hz, 1 min.		
Ambient temperature range	-20°C ... +60°C		
Dimensions (W x H x D)	55 mm x 67 mm x 85 mm		
Conductor cross section	0.2 mm ² ... 2.5 mm ²		
Housing design	Polyamide PA non-reinforced, green		
Electromagnetic compatibility	CE compliant		
Input	MCR-SL-S-100...	MCR-SL-S-200...	MCR-SL-S-400...
Input current	0 A AC ... 100 A AC	0 A AC ... 200 A AC	0 A AC ... 400 A AC
Measuring range	0 A ... 50/75/100 A	0 A ... 100/150/200 A	0 A ... 200/300/400 A
Response threshold	1% of end value		
Frequency range	30 Hz ... 6000 Hz		
Curve type	Sinusoidal and non-sinusoidal		
Overload capacity (continuous)	No limitation		
Surge strength (for 1 s)	No limitation		
Connection method	Clamp-on cable design for 18.5 mm Ø (insulated conductor)		
Output	MCR-SL-S-...-U	MCR-SL-S-...-I-LP	
Output signal	0 V ... (5)10 V	4 mA ... 20 mA	
Max. output signal	7 V (0...5 V); 14 V (0...10 V)	25 mA	
Load	≥ 10 kΩ	(U _B - 12 V) / 20 mA	
Approvals			
UL/C-UL Listed UL 508	Yes		
UL/C-UL Listed UL 1604 Class I, Division 2	In preparation		

Features

- Can be retrofitted with the open up Rogowski coil
- Choice of voltage or current output
- Measuring range selection with slide switch
- True r.m.s. value measurement from 30 Hz ... 6000 Hz
- Clamp-on cable design for 18.5 mm \varnothing (insulated conductor)

Block Diagrams

MCR-SL-S-...00-U

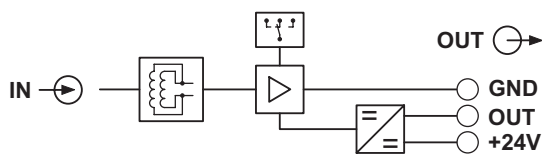

MCR-SL-S-...00-I-LP

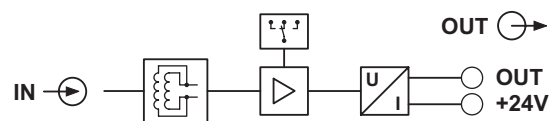

Current Measurement

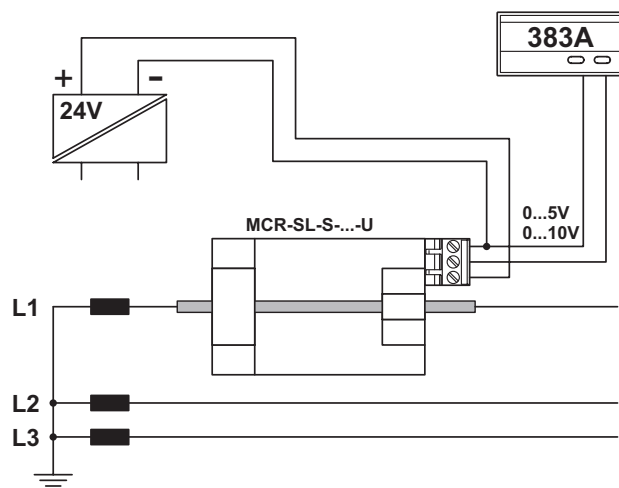

Figure 1 Current measurement

Current Monitoring

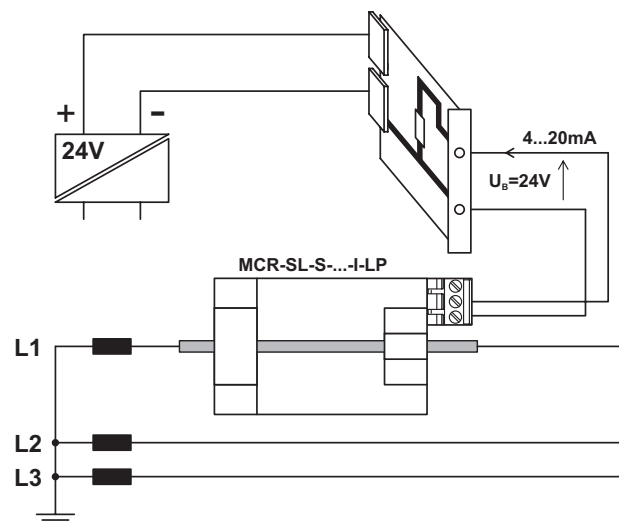

Figure 2 Current monitoring