

## 阅读申明

- 1.本站收集的数据手册和产品资料都来自互联网，版权归原作者所有。如读者和版权方有任何异议请及时告之，我们将妥善解决。
- 2.本站提供的中文数据手册是英文数据手册的中文翻译，其目的是协助用户阅读，该译文无法自动跟随原稿更新，同时也可能存在翻译上的不当。建议读者以英文原稿为参考以便获得更精准的信息。
- 3.本站提供的产品资料，来自厂商的技术支持或者使用者的心得体会等，其内容可能存在描述上的差异，建议读者做出适当判断。
- 4.如需与我们联系，请发邮件到marketing@iczoom.com，主题请标有“数据手册”字样。

## Read Statement

1. The datasheets and other product information on the site are all from network reference or other public materials, and the copyright belongs to the original author and original published source. If readers and copyright owners have any objections, please contact us and we will deal with it in a timely manner.
2. The Chinese datasheets provided on the website is a Chinese translation of the English datasheets. Its purpose is for reader's learning exchange only and do not involve commercial purposes. The translation cannot be automatically updated with the original manuscript, and there may also be improper translations. Readers are advised to use the English manuscript as a reference for more accurate information.
3. All product information provided on the website refer to solutions from manufacturers' technical support or users the contents may have differences in description, and readers are advised to take the original article as the standard.
4. If you have any questions, please contact us at marketing@iczoom.com and mark the subject with "Datasheets" .

## FEATURES

- \* High input-output isolation voltage  
(  $V_{iso} = 5,000V_{rms}$  )
- \* Current transfer ratio  
( CTR : MIN. 10% at  $I_F = 10mA$ ,  $V_{CE} = 10V$  )
- \* Dual-in-line package :  
H11A1, H11A2, H11A3, H11A4, H11A5
- \* Wide lead spacing package :  
H11A1M, H11A2M, H11A3M, H11A4M, H11A5M
- \* Surface mounting package :  
H11A1S, H11A2S, H11A3S, H11A4S, H11A5S
- \* Tape and reel packaging :  
(TYPE I) H11A1S-TA, H11A2S-TA, H11A3S-TA, H11A4S-TA, H11A5S-TA  
(TYPE II) H11A1S-TA1, H11A2S-TA1, H11A3S-TA1, H11A4S-TA1, H11A5S-TA1
- \* UL approved ( No. E113898 )
- \* FIMKO approved ( No. 209049 )
- \* NEMKO approved ( No. P99102464 )
- \* DEMKO approved ( No. 99-04182 )
- \* SEMKO approved ( No. 9943380 / 01-20 )
- \* VDE approved ( No. 094722 )
- \* CSA approve in progress

## OUTLINE DIMENSIONS

### Dual-in-line package:

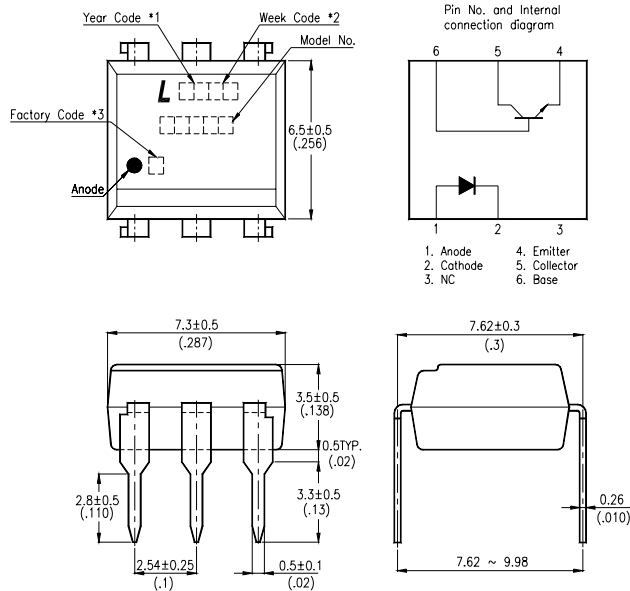

### Wide lead spacing package :

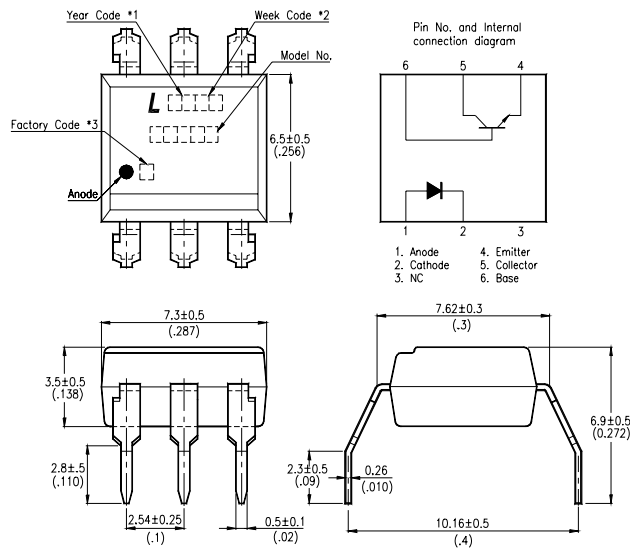

- \*1. Year date code.
- \*2. 2-digit work week.
- \*3. Factory identification mark shall be marked (Z : Taiwan, Y : Thailand).
- \*4. Model No.: H11A1, H11A2, H11A3, H11A4, H11A5

## OUTLINE DIMENSIONS

Surface mounting package :

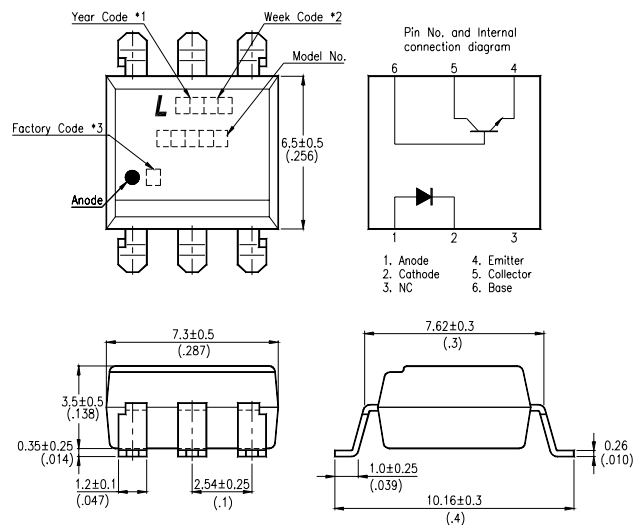

- \*1. Year date code.
- \*2. 2-digit work week.
- \*3. Factory identification mark shall be marked (Z : Taiwan, Y : Thailand).
- \*4. Model No.: H11A1, H11A2, H11A3, H11A4, H11A5

## TAPING DIMENSIONS

### Tape and reel packaging ( TYPE I ):

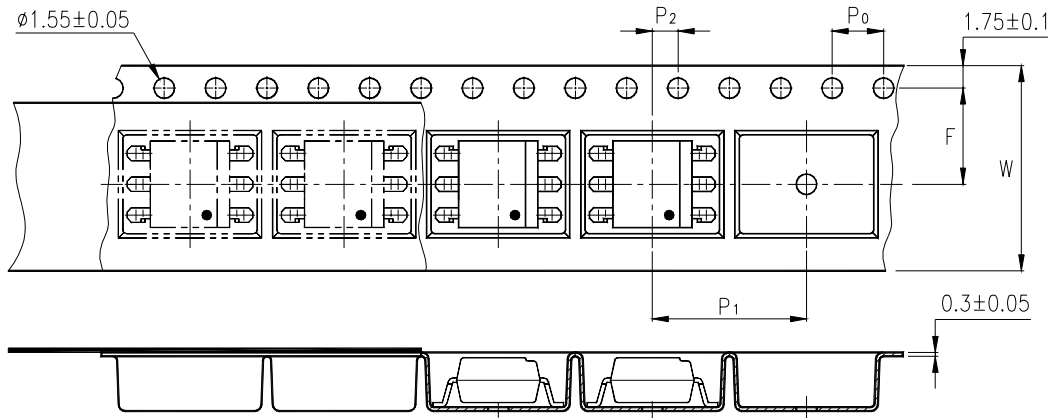

### Tape and reel packaging ( TYPE II ):

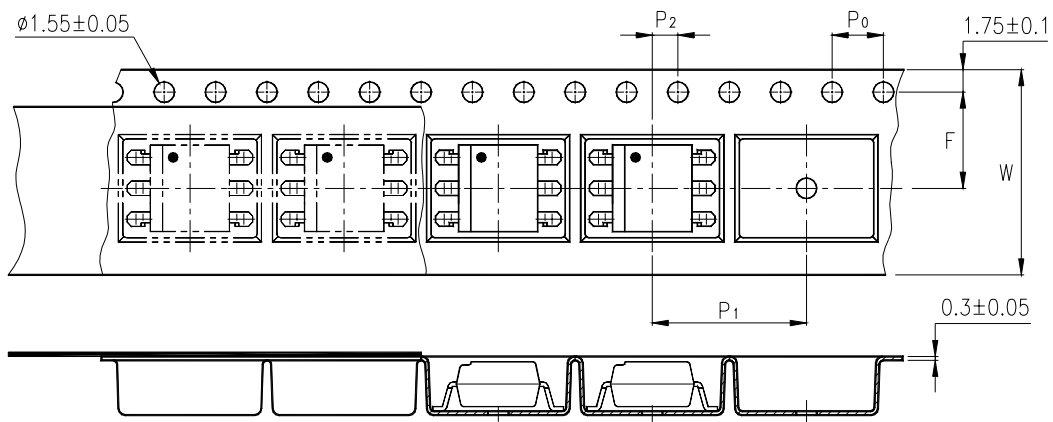

Description	Symbol	Dimensions in mm ( inches )
Tape wide	W	16 ± 0.3 ( .63 )
Pitch of sprocket holes	P <sub>0</sub>	4 ± 0.1 ( .15 )
Distance of compartment	F	7.5 ± 0.1 ( .295 )
Distance of compartment to compartment	P <sub>2</sub>	2 ± 0.1 ( .079 )
Distance of compartment to compartment	P <sub>1</sub>	12 ± 0.1 ( .472 )

## ABSOLUTE MAXIMUM RATING

( Ta = 25°C )

PARAMETER		SYMBOL	RATING	UNIT
INPUT	Forward Current	I <sub>F</sub>	60	mA
	Reverse Voltage	V <sub>R</sub>	6	V
	Power Dissipation	P	100	mW
OUTPUT	Collector - Emitter Voltage	V <sub>CEO</sub>	30	V
	Emitter - Collector Voltage	V <sub>ECO</sub>	7	V
	Collector - Base Voltage	V <sub>CBO</sub>	70	V
	Collector Current	I <sub>C</sub>	150	mA
	Collector Power Dissipation	P <sub>C</sub>	150	mW
Total Power Dissipation		P <sub>tot</sub>	250	mW
*1	Isolation Voltage	V <sub>iso</sub>	5,000	V <sub>rms</sub>
Operating Temperature		T <sub>opr</sub>	-55 ~ +100	°C
Storage Temperature		T <sub>stg</sub>	-55 ~ +150	°C
*2	Soldering Temperature	T <sub>sol</sub>	260	°C

\*1. AC For 1 Minute, R.H. = 40 ~ 60%

Isolation voltage shall be measured using the following method.

- (1) Short between anode and cathode on the primary side and between collector, emitter and base on the secondary side.
- (2) The isolation voltage tester with zero-cross circuit shall be used.
- (3) The waveform of applied voltage shall be a sine wave.

\*2. For 10 Seconds

### ELECTRICAL - OPTICAL CHARACTERISTICS

( Ta = 25°C )

PARAMETER		SYMBOL	MIN.	TYP.	MAX.	UNIT	CONDITIONS	
INPUT	Forward Voltage	V <sub>F</sub>	—	1.2	1.5	V	I <sub>F</sub> =10mA	
	Reverse Current	I <sub>R</sub>	—	—	10	μA	V <sub>R</sub> =6V	
	Terminal Capacitance	C <sub>t</sub>	—	18	—	pF	V=0, f=1MHz	
OUTPUT	Collector Dark Current	I <sub>CEO</sub>	—	—	50	nA	V <sub>CE</sub> =10V, I <sub>F</sub> =0	
	Collector-Emitter Breakdown Voltage	BV <sub>CEO</sub>	30	—	—	V	I <sub>C</sub> =0.1mA I <sub>F</sub> =0	
	Emitter-Collector Breakdown Voltage	BV <sub>ECO</sub>	7	—	—	V	I <sub>E</sub> =10μA I <sub>F</sub> =0	
	Collector-Base Breakdown Voltage	BV <sub>CBO</sub>	70	—	—	V	I <sub>C</sub> =0.1mA I <sub>F</sub> =0	
	Collector-Emitter Capacitance	C <sub>CE</sub>	—	12	—	pF	V=0V, f=1MHz	
	Collector-Base Capacitance	C <sub>CB</sub>	—	17	—	pF	V <sub>CB</sub> =0V, f=1MHz	
	Emitter-Base Capacitance	C <sub>EB</sub>	—	25	—	pF	V <sub>EB</sub> =0V, f=1MHz	
TRANSFER CHARACTERISTICS	* Current Transfer Ratio	H11A1	CTR	50	—	—	%	I <sub>F</sub> =10mA V <sub>CE</sub> =10V
		H11A2		20	—	—		
		H11A3		20	—	—		
		H11A4		10	—	—		
		H11A5		30	—	—		
	Collector-Emitter Saturation Voltage	V <sub>CE(sat)</sub>	—	0.15	0.4	V	I <sub>F</sub> =10mA I <sub>C</sub> =0.5mA	
	Isolation Resistance	R <sub>iso</sub>	100	—	—	GΩ	DC500V 40 ~ 60% R.H.	
	Floating Capacitance	C <sub>f</sub>	—	0.3	—	pF	V=0, f=1MHz	
	Response Time (Rise)	t <sub>r</sub>	—	2.8	—	μs	V <sub>CC</sub> =10V, I <sub>F</sub> =10mA R <sub>L</sub> =100Ω	
	Response Time (Fall)	t <sub>f</sub>	—	4.5	—	μs		

$$* CTR = \frac{I_C}{I_F} \times 100\%$$

## CHARACTERISTICS CURVES

Fig.1 Forward Current vs. Ambient Temperature

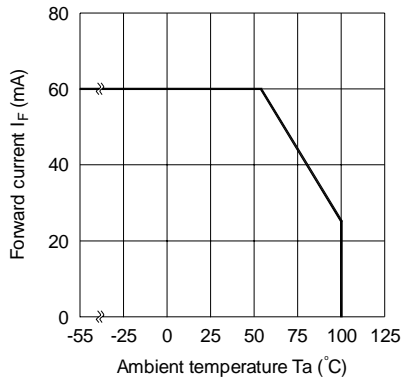

Fig.2 Collector Power Dissipation vs. Ambient Temperature

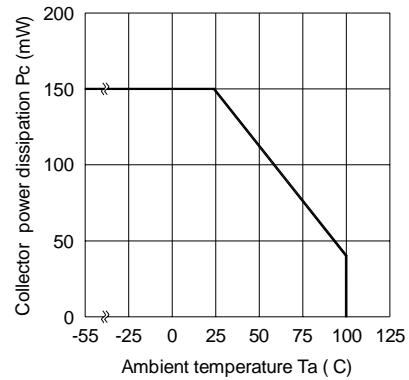

Fig.3 Collector-emitter saturation Voltage vs. Forward current

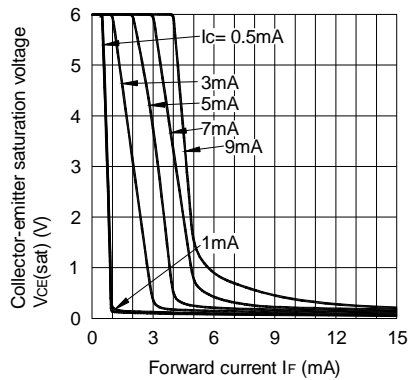

Fig.4 Turn-On Switching Times

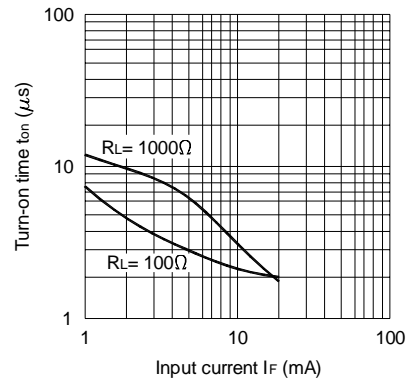

Fig.5 Current Transfer Ratio vs. Forward Current

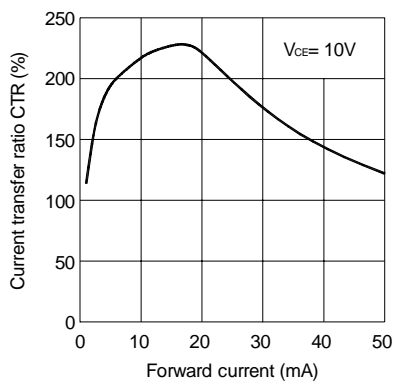
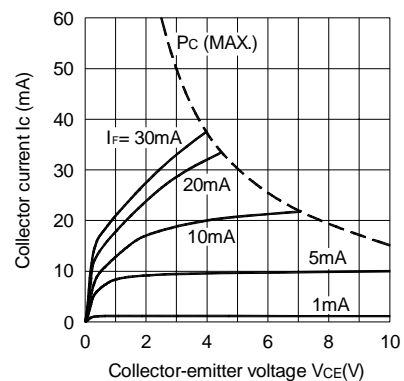

Fig.6 Collector Current vs. Collector-emitter Voltage





## CHARACTERISTICS CURVES

Fig.7 Rise and Fall Times

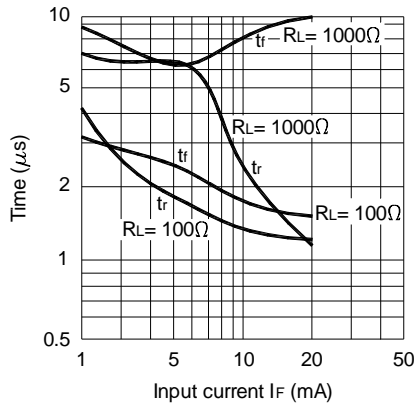
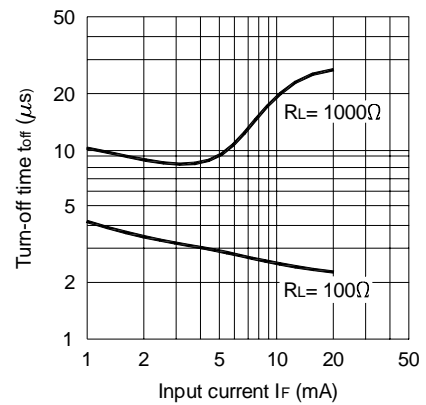
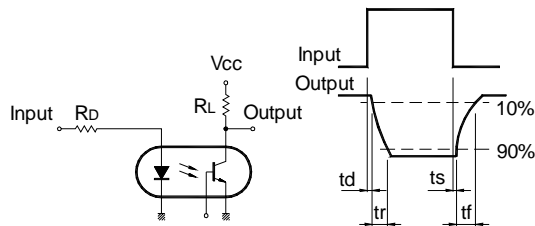

Fig.8 Turn-off Switching Times



Test Circuit for Response Time



Test Circuit for Frequency Response

