

阅读申明

- 1.本站收集的数据手册和产品资料都来自互联网，版权归原作者所有。如读者和版权方有任何异议请及时告之，我们将妥善解决。
- 2.本站提供的中文数据手册是英文数据手册的中文翻译，其目的是协助用户阅读，该译文无法自动跟随原稿更新，同时也可能存在翻译上的不当。建议读者以英文原稿为参考以便获得更精准的信息。
- 3.本站提供的产品资料，来自厂商的技术支持或者使用者的心得体会等，其内容可能存在描述上的差异，建议读者做出适当判断。
- 4.如需与我们联系，请发邮件到marketing@iczoom.com，主题请标有“数据手册”字样。

Read Statement

1. The datasheets and other product information on the site are all from network reference or other public materials, and the copyright belongs to the original author and original published source. If readers and copyright owners have any objections, please contact us and we will deal with it in a timely manner.
2. The Chinese datasheets provided on the website is a Chinese translation of the English datasheets. Its purpose is for reader's learning exchange only and do not involve commercial purposes. The translation cannot be automatically updated with the original manuscript, and there may also be improper translations. Readers are advised to use the English manuscript as a reference for more accurate information.
3. All product information provided on the website refer to solutions from manufacturers' technical support or users the contents may have differences in description, and readers are advised to take the original article as the standard.
4. If you have any questions, please contact us at marketing@iczoom.com and mark the subject with "Datasheets" .

H11AA814 SERIES

H11A617 SERIES

H11A817 SERIES

PACKAGE

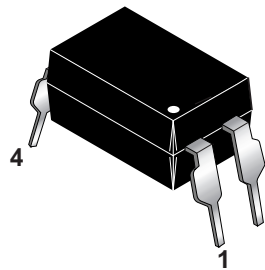

H11AA814 SCHEMATIC

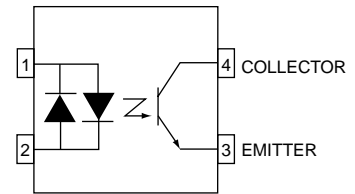

DESCRIPTION

The H11AA814 Series consists of two gallium arsenide infrared emitting diodes, connected in inverse parallel, driving a single silicon phototransistor in a 4-pin dual in-line package.

The H11A617 and H11A817 Series consists of a gallium arsenide infrared emitting diode driving a silicon phototransistor in a 4-pin dual in-line package.

FEATURES

- Compact 4-pin package
- Current transfer ratio in selected groups:

H11AA814:	20-300%	H11A817:	50-600%
H11AA814A:	50-150%	H11A817A:	80-160%
H11A617A:	40%-80%	H11A817B:	130-260%
H11A617B:	63%-125%	H11A817C:	200-400%
H11A617C:	100%-200%	H11A817D:	300-600%
H11A617D:	160%-320%		
- Minimum BV_{CEO} of 70V guaranteed

H11A617 & H11A817 SCHEMATIC

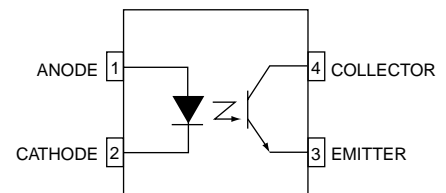

APPLICATIONS

- H11AA814 Series
- AC line monitor
 - Unknown polarity DC sensor
 - Telephone line interface
- H11A617 and H11A817 Series
- Power supply regulators
 - Digital logic inputs
 - Microprocessor inputs

H11AA814 SERIES

H11A617 SERIES

H11A817 SERIES

Parameter	Symbol	Device	Value	Units
TOTAL DEVICE				
Storage Temperature	T_{STG}	All	-55 to +150	°C
Operating Temperature	T_{OPR}	All	-55 to +100	°C
Lead Solder Temperature	T_{SOL}	All	260 for 10 sec	°C
Total Device Power Dissipation (-55°C to 50 °C)	P_D	All	200	mW
EMITTER				
Continuous Forward Current	I_F	All	50	mA
Reverse Voltage	V_R	H11A617A/B/C/D H11A817/A/B/C/D	6 5	V
Forward Current - Peak (1 μ s pulse, 300 pps)	$I_F(pk)$	All	1.0	A
LED Power Dissipation (25°C ambient) Derate above 25°C	P_D	All	100 1.33	mW mW/°C
DETECTOR				
Collector-Emitter Voltage	V_{CEO}	All	70	V
Emitter-Collector Voltage	V_{ECO}	H11AA814/A H11A617A/B/C/D H11A817/A/B/C/D	6 7 6	V
Continuous Collector Current	I_C	All	50	mA
Detector Power Dissipation (25°C ambient) Derate above 25°C	P_D	All	150 2.0	mW mW/°C

ELECTRICAL CHARACTERISTICS ($T_A = 25^\circ\text{C}$ Unless otherwise specified.)

INDIVIDUAL COMPONENT CHARACTERISTICS

Parameter	Test Conditions	Symbol	Device	Min	Typ*	Max	Unit
EMITTER							
Input Forward Voltage	$(I_F = 60 \text{ mA})$	V_F	H11A617A/B/C/D		1.35	1.65	V
	$(I_F = 20 \text{ mA})$		H11A817/A/B/C/D		1.2	1.5	
	$(I_F = \pm 20 \text{ mA})$		H11AA814/A		1.2	1.5	
Reverse Leakage Current	$(V_R = 6.0 \text{ V})$	I_R	H11A617A/B/C/D		.001	10	μA
	$(V_R = 5.0 \text{ V})$		H11A817/A/B/C/D				
DETECTOR							
Collector-Emitter Breakdown Voltage	$(I_C = 1.0 \text{ mA}, I_F = 0)$	BV_{CEO}	ALL	70	100		V
Emitter-Collector Breakdown Voltage	$(I_E = 100 \mu\text{A}, I_F = 0)$	BV_{ECO}	H11AA814/A	6	10		V
			H11A617A/B/C/D	7			
			H11A817/A/B/C/D	6			
Collector-Emitter Dark Current	$(V_{CE} = 10\text{V}, I_F = 0)$	I_{CEO}	H11AA814/A, H11A817/A/B/C/D, H11A617C/D		1	100	nA
			H11A617A/B			50	
Collector-Emitter Capacitance	$(V_{CE} = 0 \text{ V}, f = 1 \text{ MHz})$	C_{CE}	ALL		8		pF

*Typical values at $T_A = 25^\circ\text{C}$.

H11AA814 SERIES

H11A617 SERIES

H11A817 SERIES

TRANSFER CHARACTERISTICS (T _A = 25°C Unless otherwise specified.)							
DC Characteristic	Test Conditions	Symbol	Device	Min	Typ*	Max	Unit
Current Transfer Ratio	(I _F = ±1 mA, V _{CE} = 5 V) (note 1)	CTR	H11AA814	20		300	%
	(I _F = ±1 mA, V _{CE} = 5 V) (note 1)		H11AA814A	50		150	%
	(I _F = 10 mA, V _{CE} = 5 V) (note 1)		H11A617A	40		80	%
			H11A617B	63		125	%
			H11A617C	100		200	%
			H11A617D	160		320	%
	(I _F = 5 mA, V _{CE} = 5 V) (note 1)		H11A817	50		600	%
			H11A817A	80		160	%
			H11A817B	130		260	%
			H11A817C	200		400	%
	(I _F = 1 mA, V _{CE} = 5 V) (note 1)		H11A817D	300		600	%
			H11A617A	13			%
			H11A617B	22			%
			H11A617C	34			%
Collector-Emitter Saturation Voltage	(I _C = 1 mA, I _F = ±20 mA) (I _C = 2.5 mA, I _F = 10 mA) (I _C = 1 mA, I _F = 20 mA)	V _{CE (SAT)}	H11AA814/A			0.2	V
			H11A617A/B/C/D			0.4	
			H11A817A/B/C/D			0.2	
AC Characteristic							
Rise Time	(I _C = 2 mA, V _{CE} = 2 V, R _L = 100Ω) (note 2)	t _r	ALL		2.4	18	μs
Fall Time	(I _C = 2 mA, V _{CE} = 2 V, R _L = 100Ω) (note 2)	t _f	ALL		2.4	18	μs

ISOLATION CHARACTERISTICS						
Characteristic	Test Conditions	Symbol	Min	Typ*	Max	Units
Input-Output Isolation Voltage (note 3)	f = 60Hz, t = 1 min	V _{ISO}	5300			Vac(rms)
Isolation Resistance	(V _{I-O} = 500 VDC)	R _{ISO}	10 ¹¹			Ω
Isolation Capacitance	(V _{I-O} = 0, f = 1 MHz)	C _{ISO}		0.5		pf

*Typical values at T_A = 25°C.

NOTES

1. Current Transfer Ratio (CTR) = I_C/I_F x 100%.
2. For test circuit setup and waveforms, refer to Figure 8.
3. For this test, Pins 1 and 2 are common, and Pins 3 and 4 are common.

H11AA814 SERIES

H11A617 SERIES

H11A817 SERIES

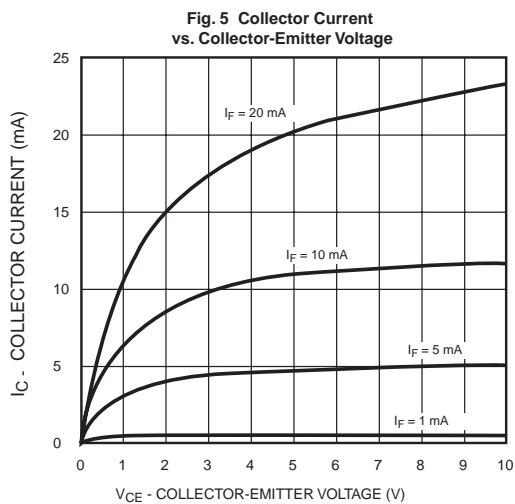
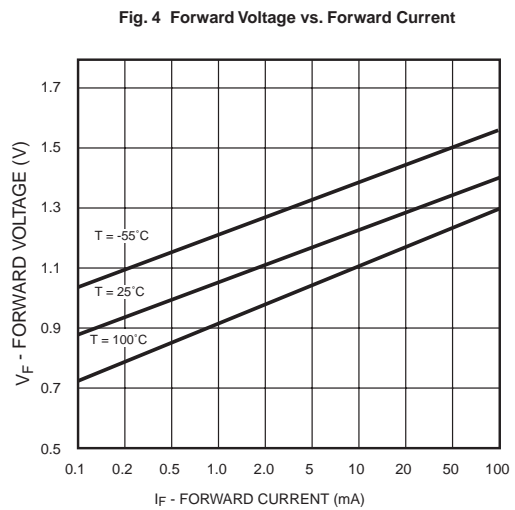
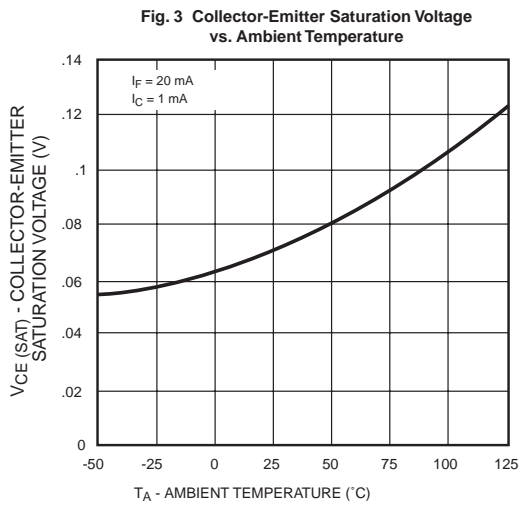
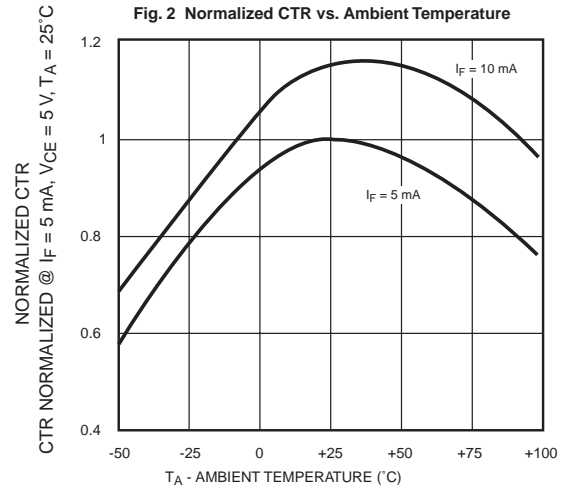
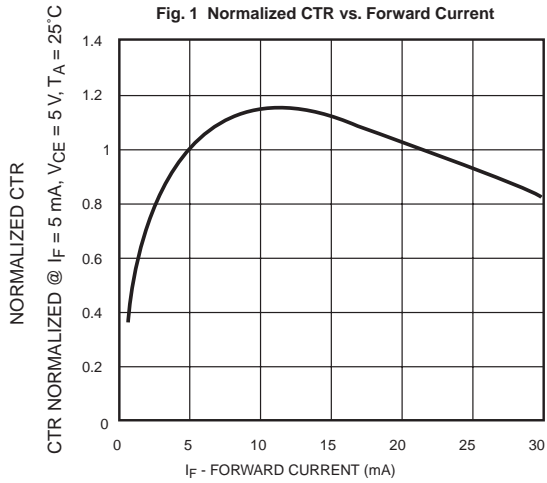

H11AA814 SERIES

H11A617 SERIES

H11A817 SERIES

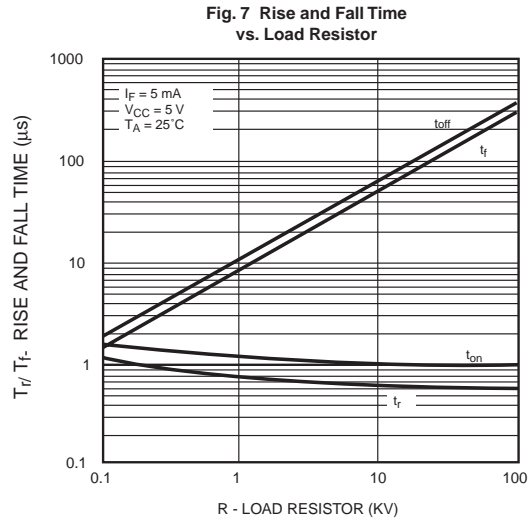
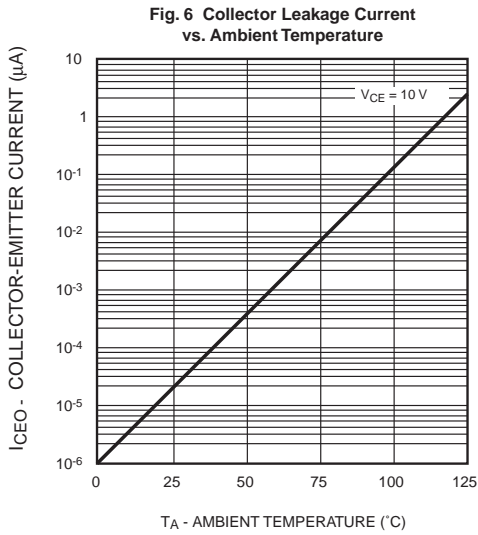
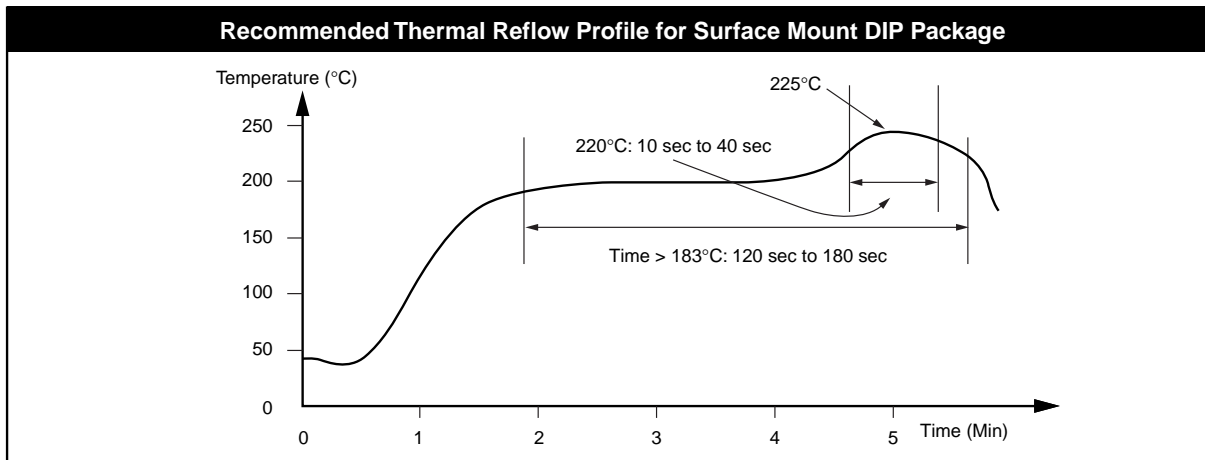
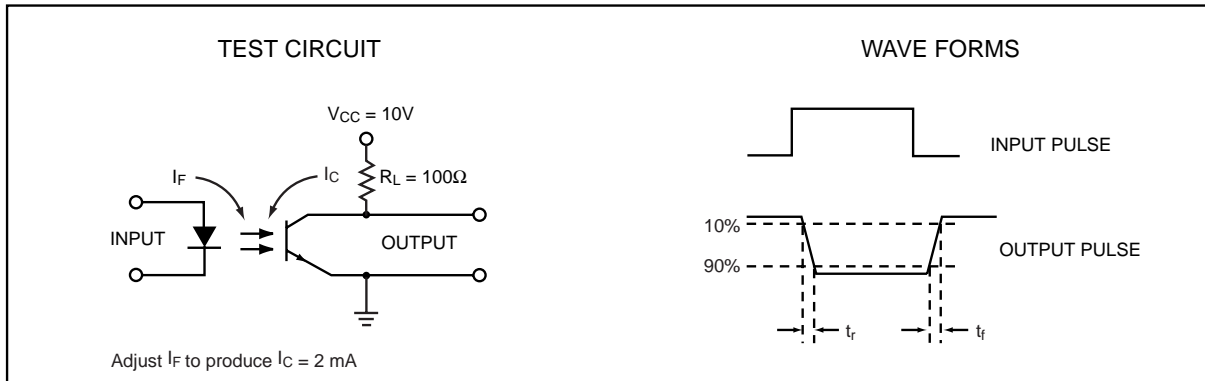

Figure 8. Switching Time Test Circuit and Waveforms



H11AA814 SERIES

H11A617 SERIES

H11A817 SERIES

Package Dimensions (Through Hole)

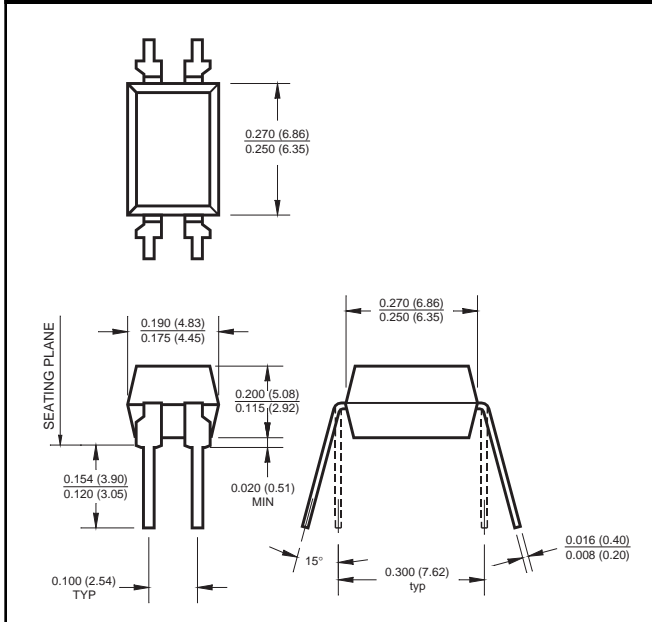

Package Dimensions (Surface Mount)

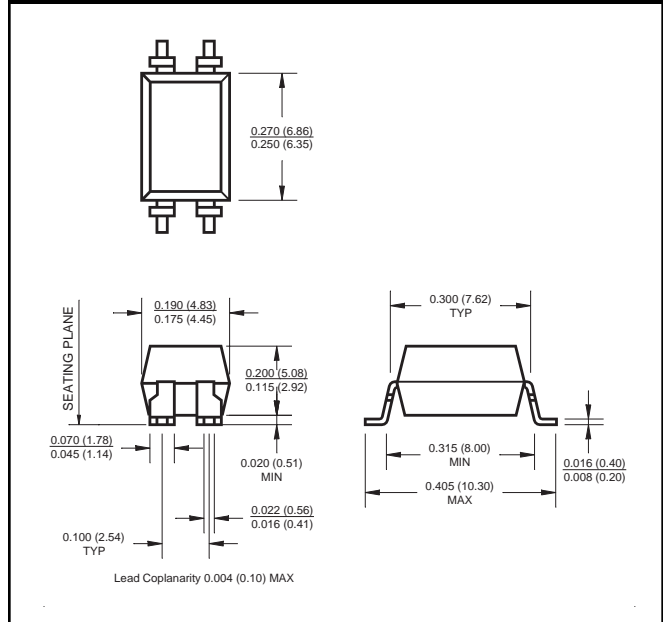

Package Dimensions (0.4" Lead Spacing)

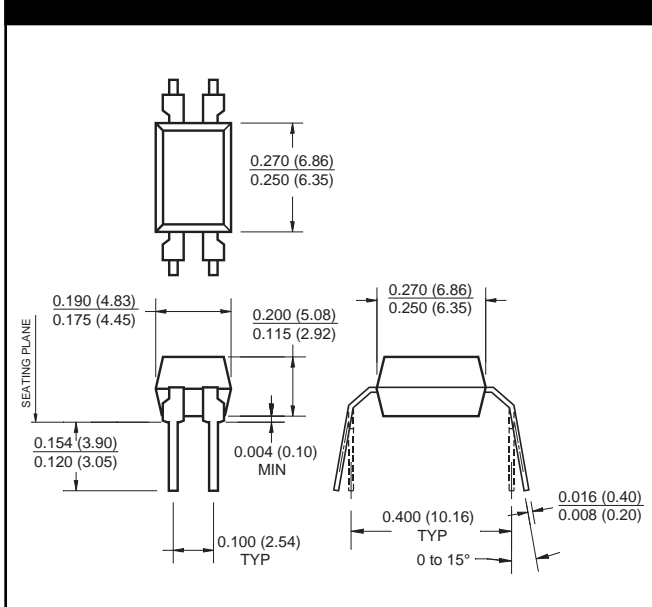

Footprint Dimensions (Surface Mount)

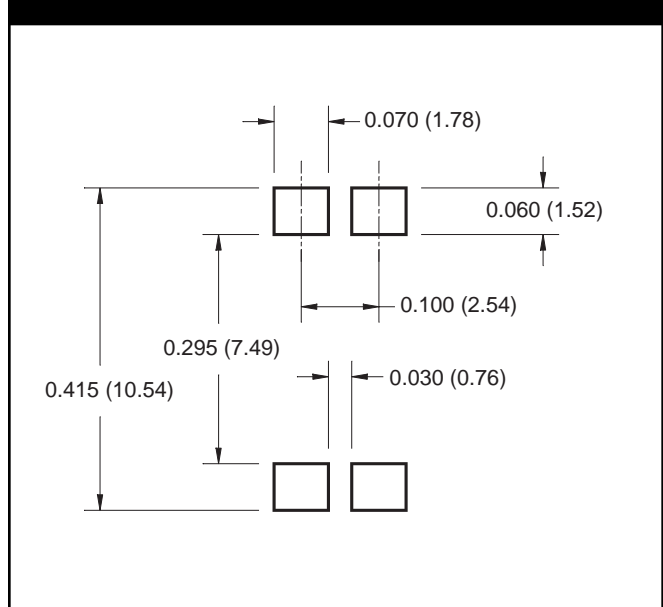

NOTE

All dimensions are in inches (millimeters)

H11AA814 SERIES

H11A617 SERIES

H11A817 SERIES

ORDERING INFORMATION

Option	Order Entry Identifier	Description
S	.S	Surface Mount Lead Bend
SD	.SD	Surface Mount; Tape and reel
W	.W	0.4" Lead Spacing
300	.300	VDE 0884
300W	.300W	VDE 0884, 0.4" Lead Spacing
3S	.3S	VDE 0884, Surface Mount
3SD	.3SD	VDE 0884, Surface Mount, Tape & Reel

MARKING INFORMATION

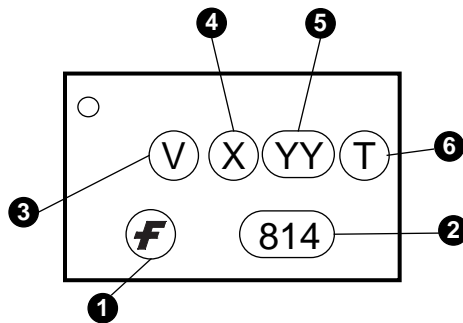

Definitions	
1	Fairchild logo
2	Device number
3	VDE mark (Note: Only appears on parts ordered with VDE option – See order entry table)
4	One digit year code
5	Two digit work week ranging from '01' to '53'
6	Assembly package code

H11AA814 SERIES

H11A617 SERIES

H11A817 SERIES

Carrier Tape Specifications

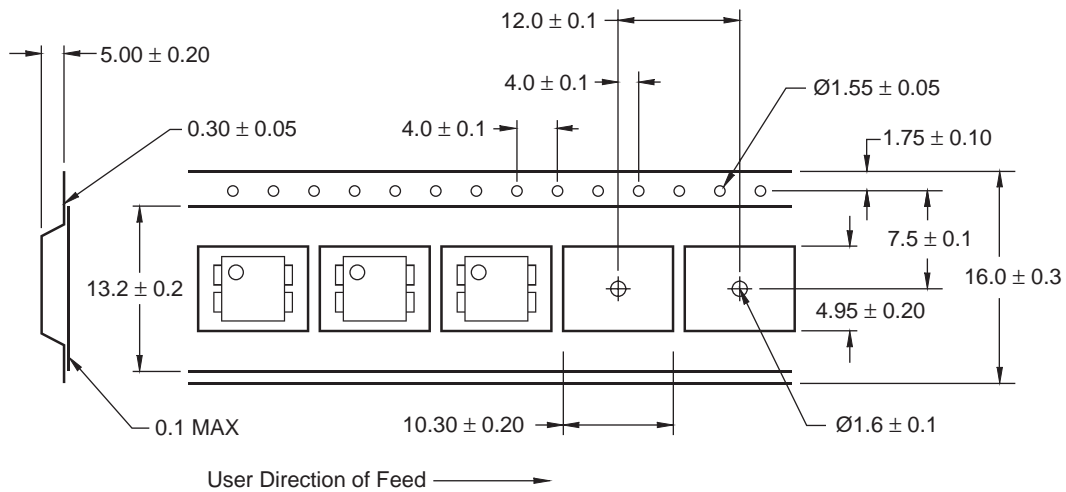

NOTE
All dimensions are in millimeters

H11AA814 SERIES

H11A617 SERIES

H11A817 SERIES

DISCLAIMER

FAIRCHILD SEMICONDUCTOR RESERVES THE RIGHT TO MAKE CHANGES WITHOUT FURTHER NOTICE TO ANY PRODUCTS HEREIN TO IMPROVE RELIABILITY, FUNCTION OR DESIGN. FAIRCHILD DOES NOT ASSUME ANY LIABILITY ARISING OUT OF THE APPLICATION OR USE OF ANY PRODUCT OR CIRCUIT DESCRIBED HEREIN; NEITHER DOES IT CONVEY ANY LICENSE UNDER ITS PATENT RIGHTS, NOR THE RIGHTS OF OTHERS.

LIFE SUPPORT POLICY

FAIRCHILD'S PRODUCTS ARE NOT AUTHORIZED FOR USE AS CRITICAL COMPONENTS IN LIFE SUPPORT DEVICES OR SYSTEMS WITHOUT THE EXPRESS WRITTEN APPROVAL OF THE PRESIDENT OF FAIRCHILD SEMICONDUCTOR CORPORATION. As used herein:

1. Life support devices or systems are devices or systems which, (a) are intended for surgical implant into the body, or (b) support or sustain life, and (c) whose failure to perform when properly used in accordance with instructions for use provided in the labeling, can be reasonably expected to result in a significant injury of the user.
2. A critical component in any component of a life support device or system whose failure to perform can be reasonably expected to cause the failure of the life support device or system, or to affect its safety or effectiveness.