

阅读申明

- 1.本站收集的数据手册和产品资料都来自互联网，版权归原作者所有。如读者和版权方有任何异议请及时告之，我们将妥善解决。
- 2.本站提供的中文数据手册是英文数据手册的中文翻译，其目的是协助用户阅读，该译文无法自动跟随原稿更新，同时也可能存在翻译上的不当。建议读者以英文原稿为参考以便获得更精准的信息。
- 3.本站提供的产品资料，来自厂商的技术支持或者使用者的心得体会等，其内容可能存在描述上的差异，建议读者做出适当判断。
- 4.如需与我们联系，请发邮件到marketing@iczoom.com，主题请标有“数据手册”字样。

Read Statement

1. The datasheets and other product information on the site are all from network reference or other public materials, and the copyright belongs to the original author and original published source. If readers and copyright owners have any objections, please contact us and we will deal with it in a timely manner.
2. The Chinese datasheets provided on the website is a Chinese translation of the English datasheets. Its purpose is for reader's learning exchange only and do not involve commercial purposes. The translation cannot be automatically updated with the original manuscript, and there may also be improper translations. Readers are advised to use the English manuscript as a reference for more accurate information.
3. All product information provided on the website refer to solutions from manufacturers' technical support or users the contents may have differences in description, and readers are advised to take the original article as the standard.
4. If you have any questions, please contact us at marketing@iczoom.com and mark the subject with "Datasheets" .

H11AA1

H11AA3

H11AA2

H11AA4

DESCRIPTION

The H11AAX series consists of two gallium-arsenide infrared emitting diodes connected in inverse parallel driving a single silicon phototransistor output.

FEATURES

- Bi-polar emitter input
- Built-in reverse polarity input protection
- Underwriters Laboratory (UL) recognized — File #E90700
- VDE approved — File #E94766 (ordering option '300')

APPLICATIONS

- AC line monitor
- Unknown polarity DC sensor
- Telephone line interface

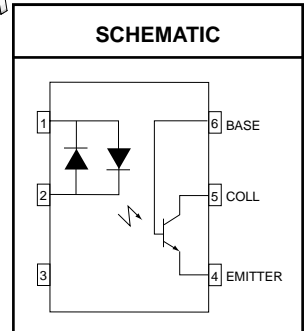
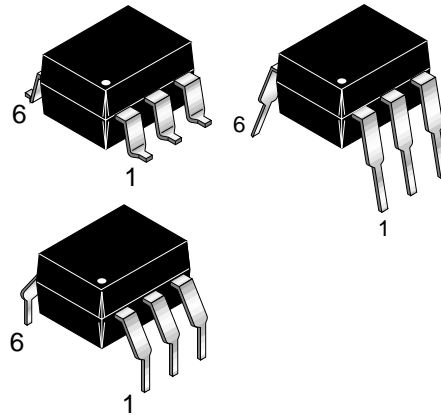

Parameter	Symbol	Device	Value	Units
TOTAL DEVICE				
Storage Temperature	T_{STG}	All	-55 to +150	°C
Operating Temperature	T_{OPR}	All	-55 to +100	°C
Lead Solder Temperature	T_{SOL}	All	260 for 10 sec	°C
Total Device Power Dissipation Derate Linearly From 25°C	P_D	All	350	mW
			4.6	mW/°C
EMITTER				
Continuous Forward Current	I_F	All	100	mA
Forward Current - Peak (1 μ s pulse, 300 pps)	$I_F(pk)$	All	± 1.0	A
LED Power Dissipation Derate Linearly From 25°C	P_D	All	200	mW
			2.6	mW/°C
DETECTOR				
Detector Power Dissipation Derate above 25°C	P_D	All	300	mW
			4.0	mW/°C

H11AA1

H11AA3

H11AA2

H11AA4

ELECTRICAL CHARACTERISTICS ($T_A = 25^\circ\text{C}$ Unless otherwise specified.)

INDIVIDUAL COMPONENT CHARACTERISTICS

Parameter	Test Conditions	Symbol	Device	Min	Typ	Max	Unit
EMITTER							
Input Forward Voltage	$I_F = \pm 10\text{ mA}$	V_F	All		1.2	1.5	V
Capacitance	$V_F = 0\text{ V}, f = 1.0\text{ MHz}$	C_J	All		80		pF
DETECTOR							
Breakdown Voltage Collector to Emitter	$I_C = 1.0\text{ mA}, I_F = 0$	BV_{CEO}	All	30			V
Collector to Base	$I_C = 100\ \mu\text{A}, I_F = 0$	BV_{CBO}	All	70			V
Emitter to Base	$I_E = 100\ \mu\text{A}, I_F = 0$	BV_{EBO}	All	5			V
Emitter to Collector	$I_E = 100\ \mu\text{A}, I_F = 0$	BV_{ECO}	All	7			V
Leakage Current Collector to Emitter	$V_{CE} = 10\text{ V}, I_F = 0$	I_{CEO}	H11AA1,3,4 H11AA2			50 200	nA
Capacitance Collector to Emitter	$V_{CE} = 0, f = 1\text{ MHz}$	C_{CE}	All		10		pF
Collector to Base	$V_{CE} = 0, f = 1\text{ MHz}$	C_{CB}	All		80		pF
Emitter to Base	$V_{CE} = 0, f = 1\text{ MHz}$	C_{EB}	All		15		pF

TRANSFER CHARACTERISTICS ($T_A = 25^\circ\text{C}$ Unless otherwise specified.)

Characteristics	Test Conditions	Symbol	Device	Min	Typ	Max	Units
Current Transfer Ratio, Collector to Emitter	$I_F = \pm 10\text{ mA}, V_{CE} = 10\text{ V}$	CTR_{CE}	H11AA4	100			%
			H11AA3	50			
			H11AA1	20			
			H11AA2	10			
Current Transfer Ratio, Symmetry	$I_F = \pm 10\text{ mA}, V_{CE} = 10\text{ V}$ (Figure.8)		All	.33		3.0	%
Saturation Voltage Collector to Emitter	$I_F = \pm 10\text{ mA}, I_{CE} = 0.5\text{ mA}$	$V_{CE(SAT)}$	All			.40	V

ISOLATION CHARACTERISTICS

Characteristic	Test Conditions	Symbol	Min	Typ	Max	Units
Package Capacitance input/output	$V_{I-O} = 0, f = 1\text{ MHz}$	C_{I-O}		0.7		pF
Isolation Voltage	$f = 60\text{ Hz}, t = 1\text{ min.}$	V_{ISO}	5300			V
Isolation Resistance	$V_{I-O} = 500\text{ VDC}$	R_{ISO}	10^{11}			Ω

H11AA1

H11AA3

H11AA2

H11AA4

Fig. 1 Input Voltage vs. Input Current

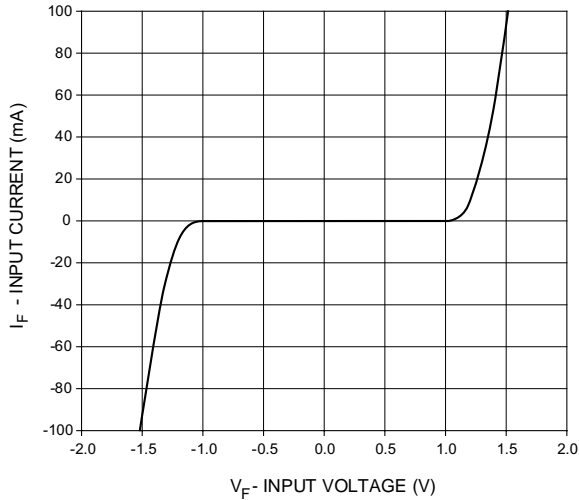

Fig. 2 Normalized CTR vs. Forward Current

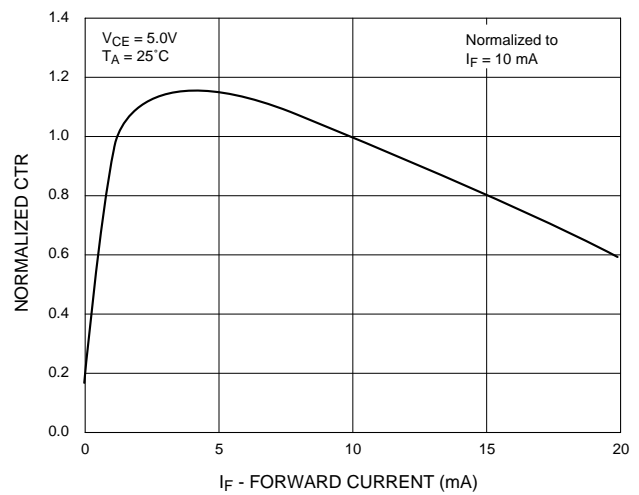

Fig. 3 Normalized CTR vs. Ambient Temperature

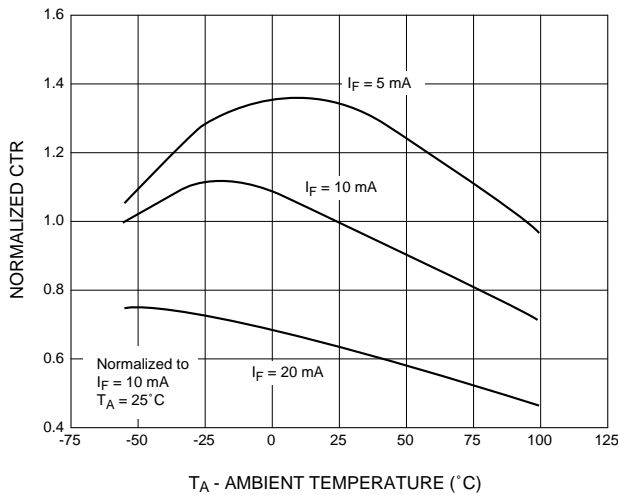

Fig. 4 CTR vs. R_{BE} (Unsaturated)

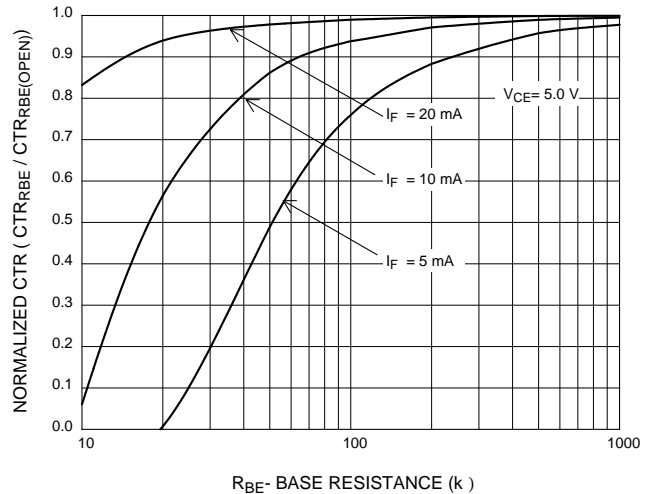

Fig. 5 CTR vs. R_{BE} (Saturated)

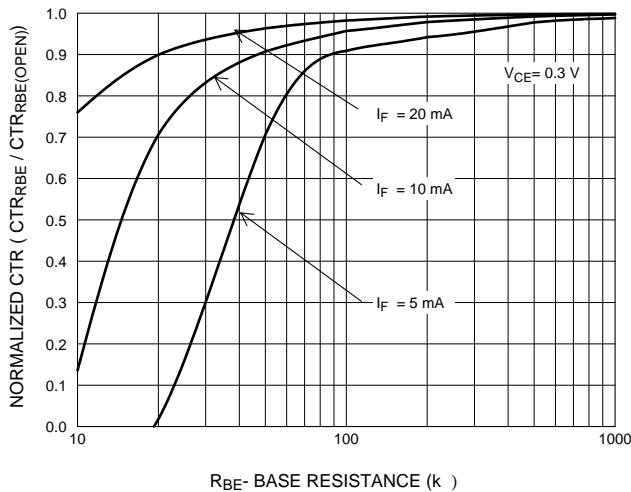
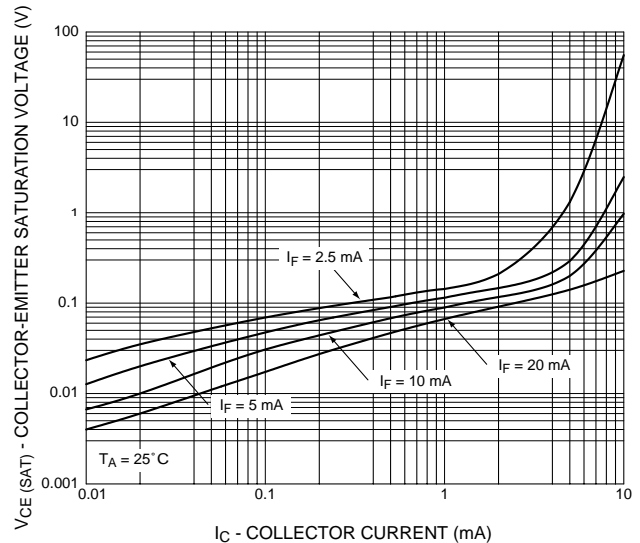

Fig. 6 Collector-Emitter Saturation Voltage vs. Collector Current



H11AA1

H11AA3

H11AA2

H11AA4

Fig. 7 Switching Speed vs. Load Resistor

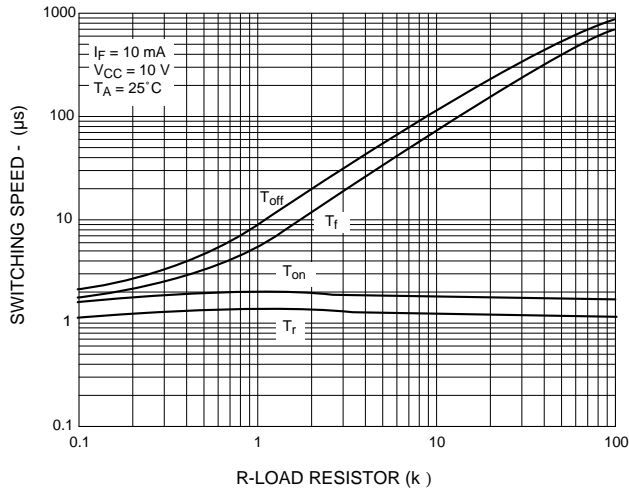

Fig. 8 Normalized t_{on} vs. R_{BE}

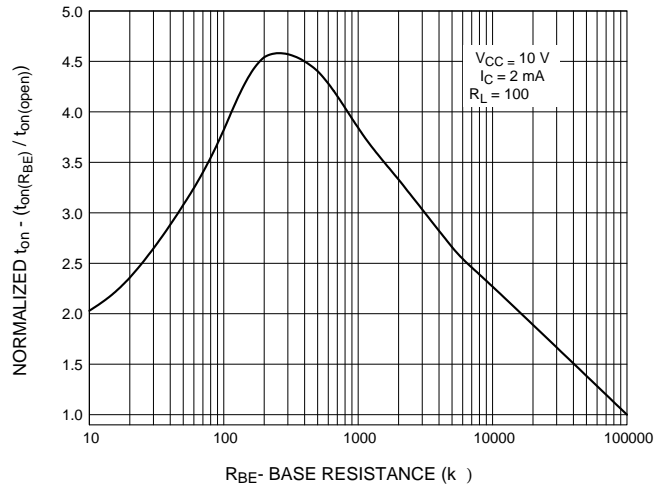

Fig. 9 Normalized t_{off} vs. R_{BE}

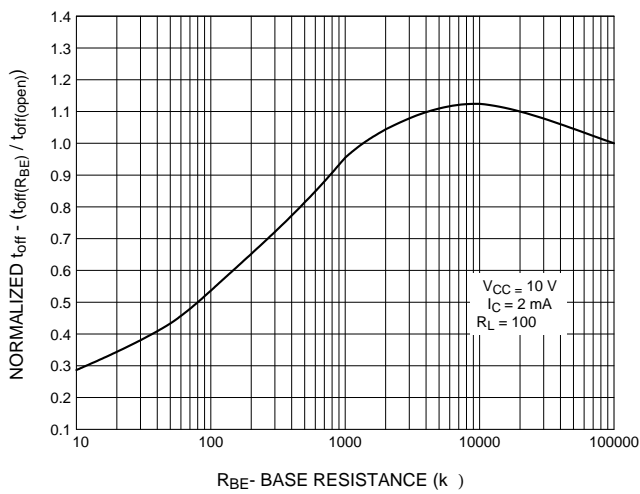

Fig. 10 Dark Current vs. Ambient Temperature

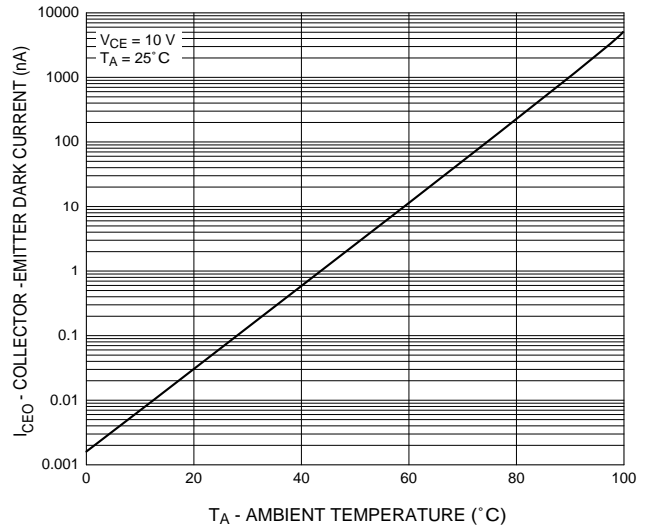
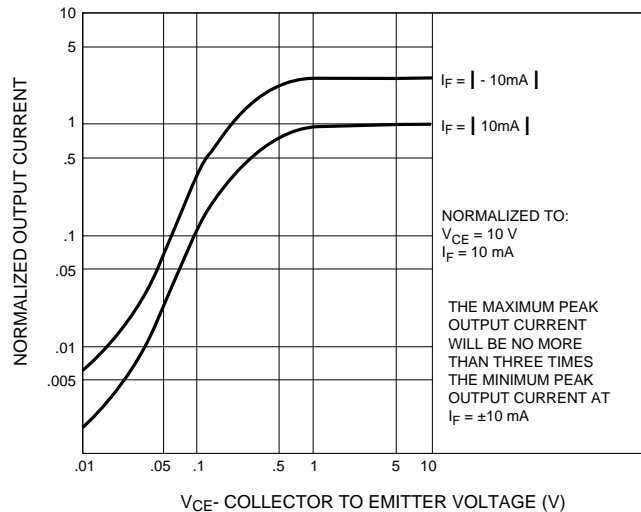

Fig. 11 Output Symmetry Characteristics



H11AA1

H11AA3

H11AA2

H11AA4

Package Dimensions (Through Hole)

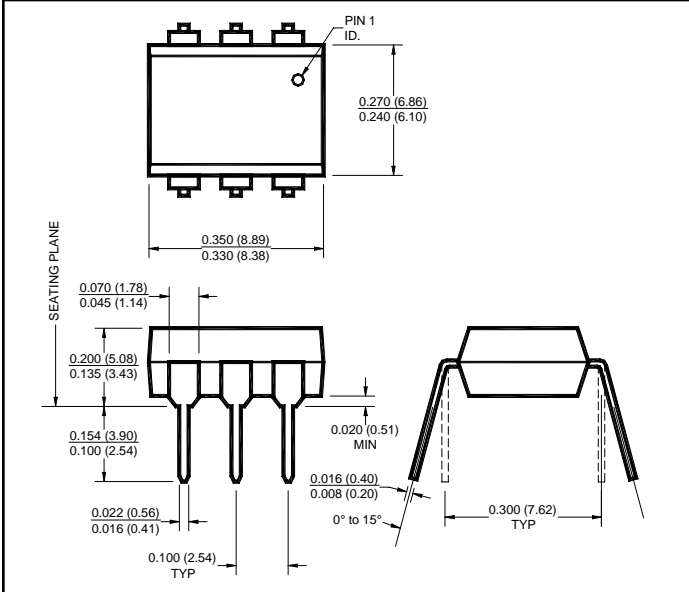

Package Dimensions (Surface Mount)

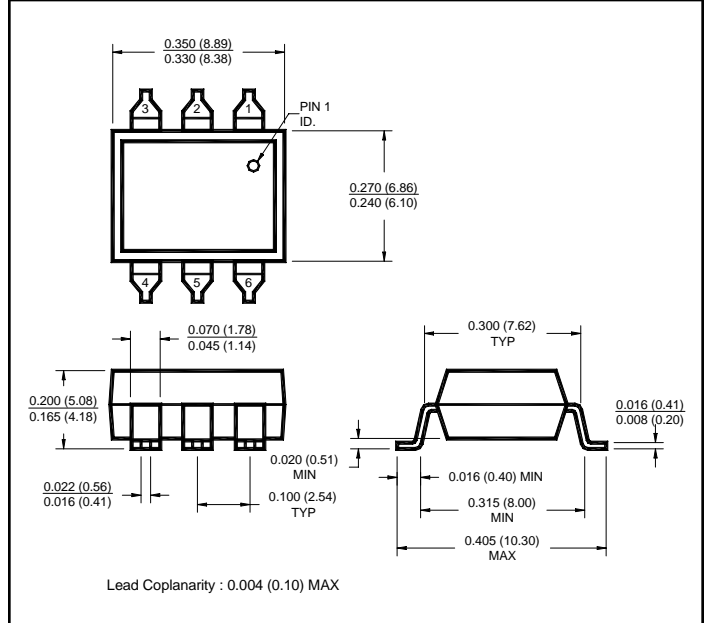

Package Dimensions (0.4" Lead Spacing)

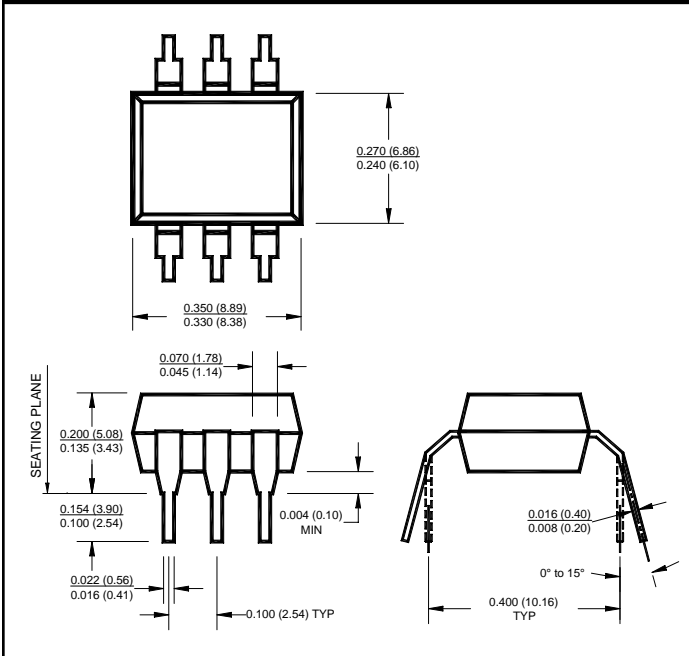

**Recommended Pad Layout for
Surface Mount Leadform**

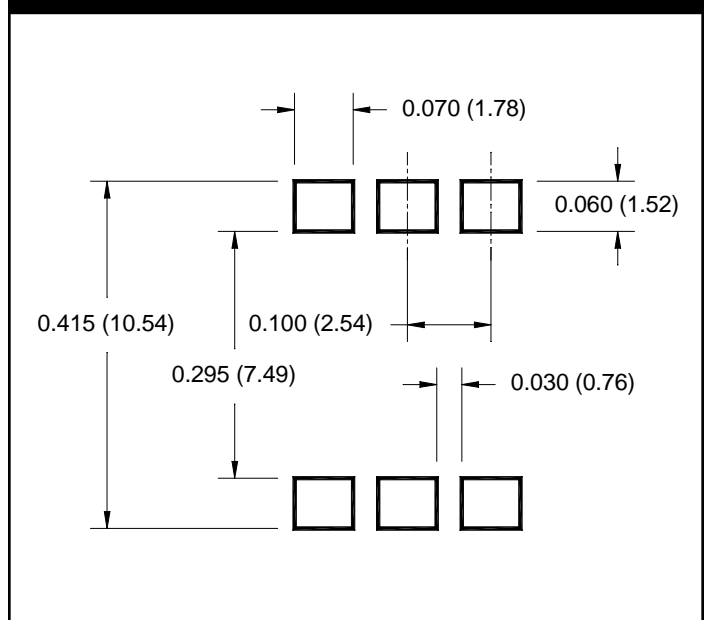

NOTE

All dimensions are in inches (millimeters)

H11AA1

H11AA3

H11AA2

H11AA4

ORDERING INFORMATION

Option	Order Entry Identifier	Description
S	.S	Surface Mount Lead Bend
SD	.SD	Surface Mount; Tape and Reel
W	.W	0.4" Lead Spacing
300	.300	VDE 0884
300W	.300W	VDE 0884, 0.4" Lead Spacing
3S	.3S	VDE 0884, Surface Mount
3SD	.3SD	VDE 0884, Surface Mount, Tape and Reel

Carrier Tape Specifications ("D" Taping Orientation)

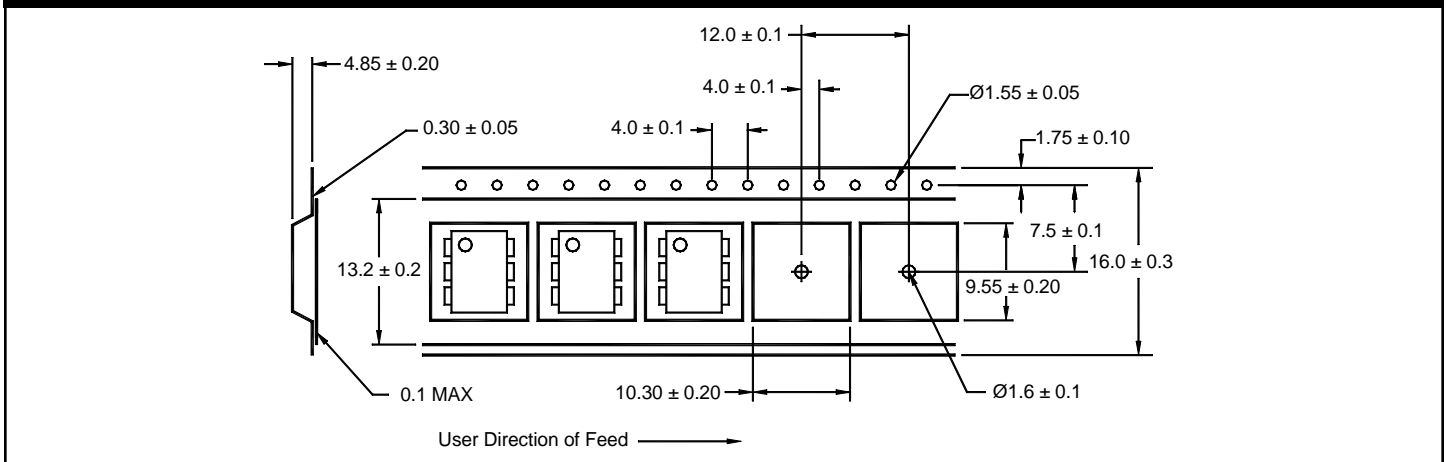

NOTE

All dimensions are millimeters

H11AA1

H11AA3

H11AA2

H11AA4

DISCLAIMER

FAIRCHILD SEMICONDUCTOR RESERVES THE THE RIGHT TO MAKE CHANGES WITHOUT FURTHER NOTICE TO ANY PRODUCTS HEREIN TO IMPROVE RELIABILITY, FUNCTION OR DESIGN. FAIRCHILD DOES NOT ASSUME ANY LIABILITY ARISING OUT OF THE APPLICATION OR USE OF ANY PRODUCT OR CIRCUIT DESCRIBED HEREIN; NEITHER DOES IT CONVEY ANY LICENSE UNDER ITS PATENT RIGHTS, NOR THE RIGHTS OF OTHERS.

LIFE SUPPORT POLICY

FAIRCHILD'S PRODUCTS ARE NOT AUTHORIZED FOR USE AS CRITICAL COMPONENTS IN LIFE SUPPORT DEVICES OR SYSTEMS WITHOUT THE EXPRESS WRITTEN APPROVAL OF THE PRESIDENT OF FAIRCHILD SEMICONDUCTOR CORPORATION. As used herein:

1. Life support devices or systems are devices or systems which, (a) are intended for surgical implant into the body, or (b) support or sustain life, and (c) whose failure to perform when properly used in accordance with instructions for use provided in labeling, can be reasonably expected to result in a significant injury of the user.
2. A critical component in any component of a life support device or system whose failure to perform can be reasonably expected to cause the failure of the life support device or system, or to affect its safety or effectiveness.