

阅读申明

- 1.本站收集的数据手册和产品资料都来自互联网，版权归原作者所有。如读者和版权方有任何异议请及时告之，我们将妥善解决。
- 2.本站提供的中文数据手册是英文数据手册的中文翻译，其目的是协助用户阅读，该译文无法自动跟随原稿更新，同时也可能存在翻译上的不当。建议读者以英文原稿为参考以便获得更精准的信息。
- 3.本站提供的产品资料，来自厂商的技术支持或者使用者的心得体会等，其内容可能存在描述上的差异，建议读者做出适当判断。
- 4.如需与我们联系，请发邮件到marketing@iczoom.com，主题请标有“数据手册”字样。

Read Statement

1. The datasheets and other product information on the site are all from network reference or other public materials, and the copyright belongs to the original author and original published source. If readers and copyright owners have any objections, please contact us and we will deal with it in a timely manner.
2. The Chinese datasheets provided on the website is a Chinese translation of the English datasheets. Its purpose is for reader's learning exchange only and do not involve commercial purposes. The translation cannot be automatically updated with the original manuscript, and there may also be improper translations. Readers are advised to use the English manuscript as a reference for more accurate information.
3. All product information provided on the website refer to solutions from manufacturers' technical support or users the contents may have differences in description, and readers are advised to take the original article as the standard.
4. If you have any questions, please contact us at marketing@iczoom.com and mark the subject with "Datasheets" .

H11AG1

H11AG2

H11AG3

DESCRIPTION

The H11AG series consists of a Gallium-Aluminum-Arsenide IRED emitting diode coupled with a silicon phototransistor in a dual in-line package. This device provides the unique feature of the high current transfer ratio at both low output voltage and low input current. This makes it ideal for use in low power logic circuits, telecommunications equipment and portable electronics isolation applications.

FEATURES

- High efficiency low degradation liquid epitaxial IRED
- Logic level compatible, input and output currents, with CMOS and LS/TTL
- High DC current transfer ratio at low input currents
- Underwriters Laboratory (UL) recognized File #E90700

APPLICATIONS

- CMOS driven solid state reliability
- Telephone ring detector
- Digital logic isolation

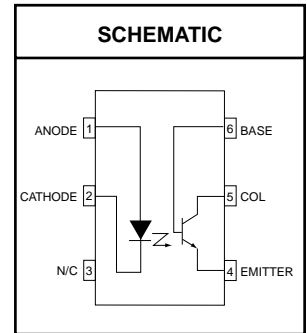
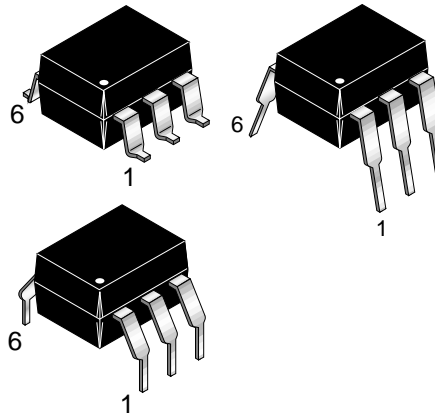

ABSOLUTE MAXIMUM RATINGS

Parameters	Symbol	Device	Value	Units
TOTAL DEVICE				
Storage Temperature	T _{STG}	All	-55 to +150	°C
Operating Temperature	T _{OPR}	All	-55 to +100	°C
Lead Solder Temperature	T _{SOL}	All	260 for 10 sec	°C
Total Device Power Dissipation @ 25°C (LED plus detector) Derate Linearly From 25°C	P _D	All	260	mW
			3.5	mW/°C
EMITTER				
Continuous Forward Current	I _F	All	50	mA
Reverse Voltage	V _R	All	6	V
Forward Current - Peak (1 μs pulse, 300 pps)	I _{F(pk)}	All	3.0	A
LED Power Dissipation 25°C Ambient Derate Linearly From 25°C	P _D	All	75	mW
			1.0	mW/°C
DETECTOR				
Detector Power Dissipation @ 25°C Derate Linearly from 25°C	P _D	All	150	mW
			2.0	mW/°C
Continuous Collector Current		All	50	mA

H11AG1

H11AG2

H11AG3

ELECTRICAL CHARACTERISTICS ($T_A = 0-70^\circ\text{C}$ Unless otherwise specified.)

INDIVIDUAL COMPONENT CHARACTERISTICS

Parameters	Test Conditions	Symbol	Device	Min	Typ	Max	Units
EMITTER							
Input Forward Voltage	$I_F = 1 \text{ mA}$	V_F	All			1.5	V
Reverse Leakage Current	$V_R = 5 \text{ V}, T_A = 25^\circ\text{C}$	I_R	All			10	μA
	$V_R = 5 \text{ V}, T_A = 70^\circ\text{C}$	I_R	All			100	μA
Capacitance	$V = 0, f = 1.0 \text{ MHz}$	C_J	All			100	pF
DETECTOR							
Breakdown Voltage							
Collector to Emitter	$I_C = 1.0 \text{ mA}, I_F = 0$	BV_{CEO}	All	30			V
Collector to Base	$I_C = 100 \mu\text{A}, I_F = 0$	BV_{CBO}	All	70			V
Emitter to Collector	$I_C = 100 \mu\text{A}, I_F = 0$	BV_{ECO}	All	7			V
Leakage Current							
Collector to Emitter	$V_{CE} = 10 \text{ V}, I_F = 0$	I_{CEO}	All		5	10	μA
Capacitance	$V_{CE} = 10 \text{ V}, f = 1 \text{ MHz}$	C_{CE}	All		2		pF

ISOLATION CHARACTERISTICS

Parameters	Test Conditions	Symbol	Min	Typ	Max	Units
Input-Output Isolation Voltage	$I_{I-0} \leq 1 \mu\text{A}, t = 1 \text{ min.}$	V_{ISO}	5300			Vac(rms)

TRANSFER CHARACTERISTICS ($T_A = 25^\circ\text{C}$ Unless otherwise specified.)

DC Characteristics	Test Conditions	Symbol	Device	Min	Typ	Max	Units
Current Transfer Ratio	$I_F = 1 \text{ mA}, V_{CE} = 5 \text{ V}$	CTR	H11AG1	300			%
			H11AG2	200			
			H11AG3	100			
	$I_F = 1 \text{ mA}, V_{CE} = 0.6 \text{ V}$	CTR	H11AG1	100			
			H11AG2	50			
			H11AG3	20			
$I_F = 0.2 \text{ mA}, V_{CE} = 1.5 \text{ V}$	CTR	H11AG1	100				
		H11AG2	50				
Saturation Voltage	$I_F = 2.0 \text{ mA}, I_C = 0.5 \text{ mA}$	$V_{CE(SAT)}$	All			.40	V
AC Characteristics							
Non-Saturated Switching Times							
Turn-On Time	$R_L = 100 \Omega, I_F = 1 \text{ mA}, V_{CC} = 5 \text{ V}$	t_{on}	All		5		μS
Turn-Off Time	$R_L = 100 \Omega, I_F = 1 \text{ mA}, V_{CC} = 5 \text{ V}$	t_{off}	All		5		μS

H11AG1

H11AG2

H11AG3

Figure 1. LED Forward Voltage vs. Forward Current

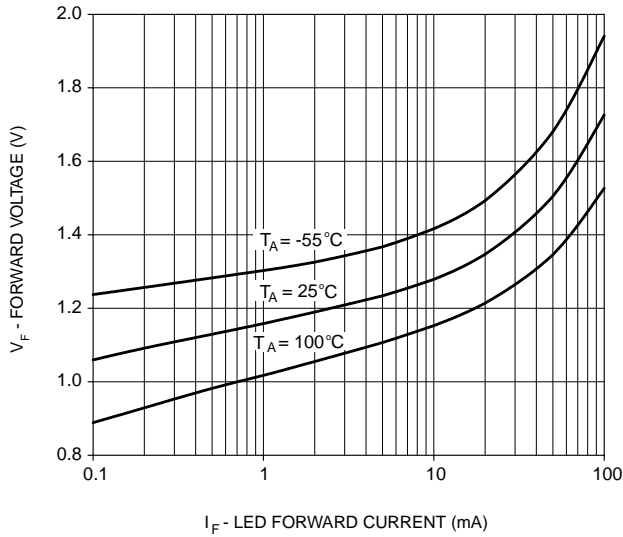

Figure 2. Normalized Current Transfer Ratio vs. Forward Current

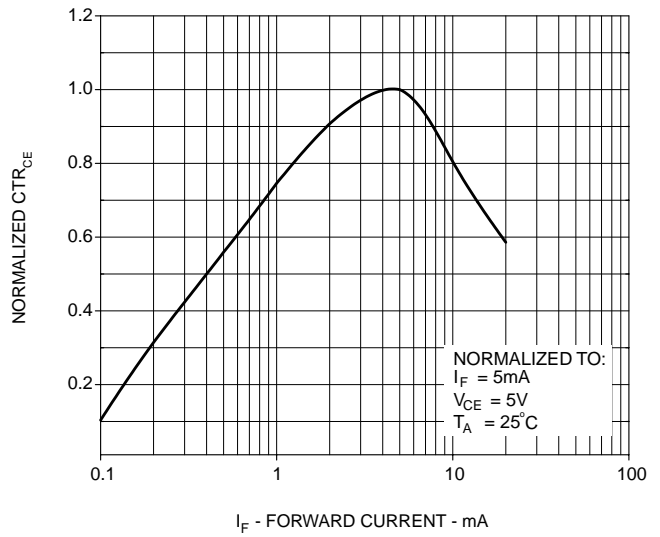

Figure 3. Normalized CTR vs. Temperature

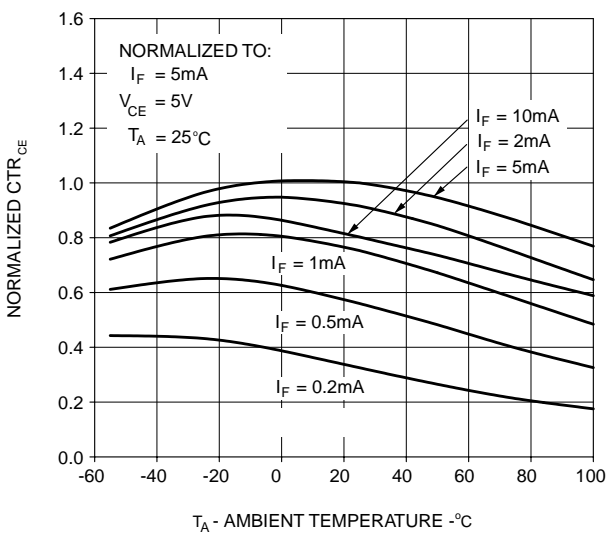
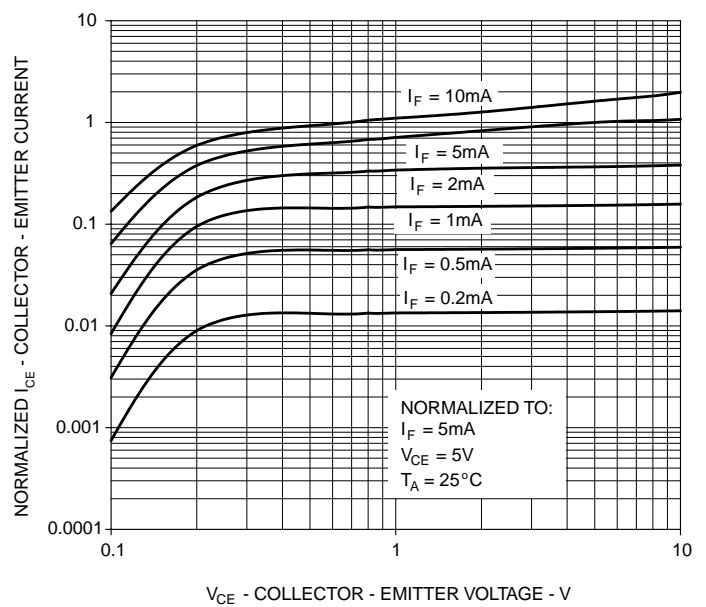

Figure 4. Normalized Collector vs. Collector - Emitter Voltage



H11AG1

H11AG2

H11AG3

Figure 5. Normalized Collector Base Photocurrent Ratio vs. Forward Current

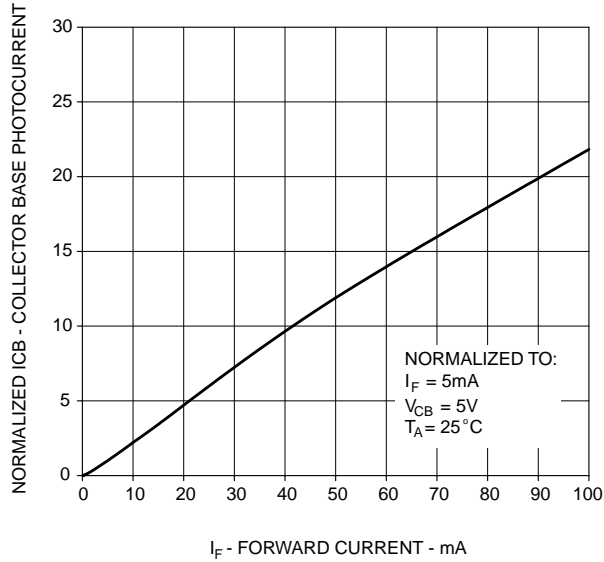

Figure 6. Normalized Collector - Base Current vs. Temperature

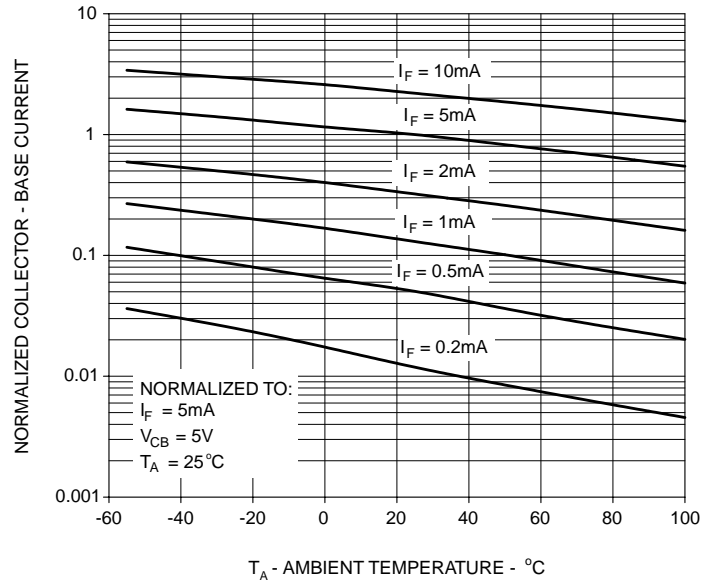
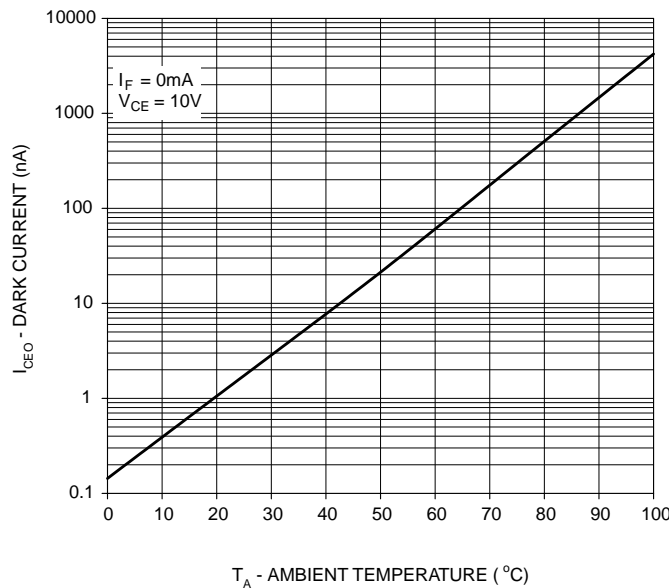

Figure 7. Collector-Emitter Dark Current vs. Ambient Temperature



H11AG1

H11AG2

H11AG3

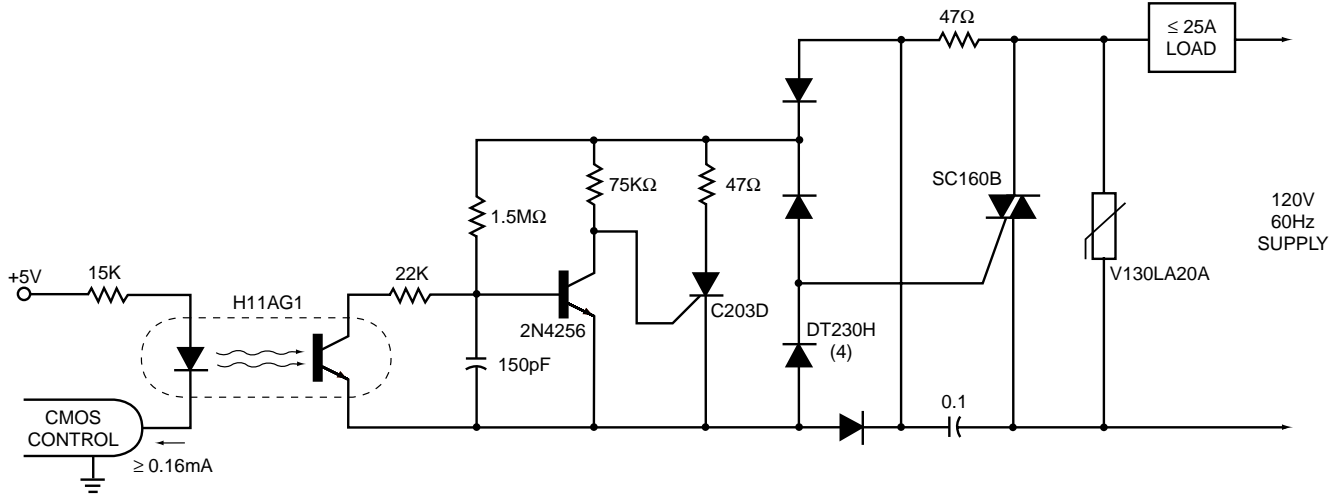
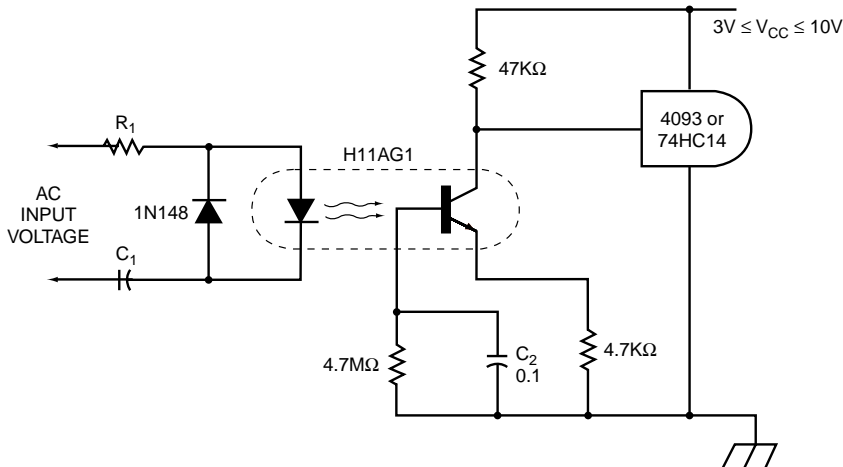

Figure 8. CMOS Input, 3KW, Zero Voltage Switching Solid State Relay

The H11AG1's superior performance at low input currents allows standard CMOS logic circuits to directly operate a 25A solid state relay. Circuit operation is as follows: power switching is provided by the SC160B, 25A triac. Its gate is controlled by the C203B via the DT230H rectifier bridge. The C203B turn-on is inhibited by the 2N4256 when line voltage is above 12V and/or the H11AG is off. False trigger and dv/dt protection are provided by the combination of the MOV® varistor and RC snubber network.



INPUT	R ₁	C ₁	Z
40-90 VRMS 20 Hz	75 K 1/10 W	0.1 μF 100 V	109K
95-135 VRMS 60 Hz	180 K 1/10 W	12 ηF 200 V	285K
200-280 VRMS 50/60 Hz	390 K 1/4 W	6.80 ηF 400 V	550K

DC component of input voltage is ignored due to C1

Figure 9. Telephone Ring Detector/A.C. Line CMOS Input Isolator

The H11AG1 uses less input power than the neon bulb traditionally used to monitor telephone and line voltages. Additionally, response time can be tailored to ignore telephone dial tap, switching transients and other undesired signals by modifying the value of C2. The high impedance to line voltage also can simply board layout spacing requirements.

H11AG1

H11AG2

H11AG3

Package Dimensions (Through Hole)

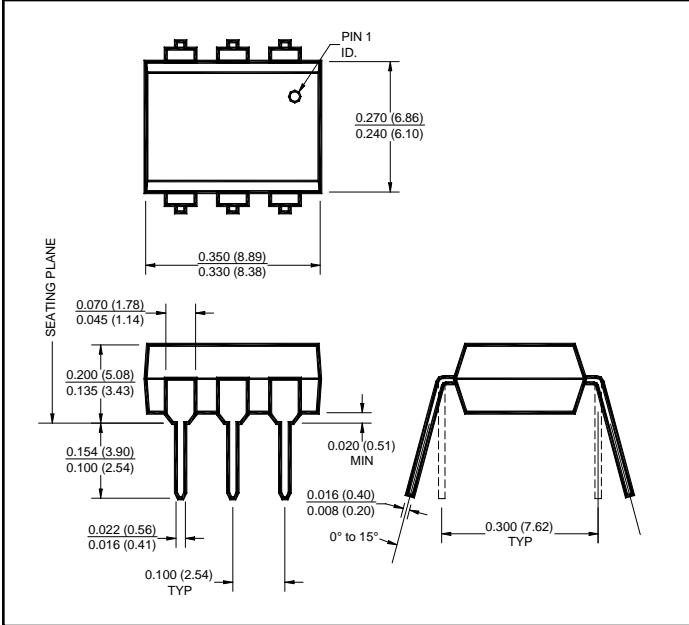

Package Dimensions (Surface Mount)

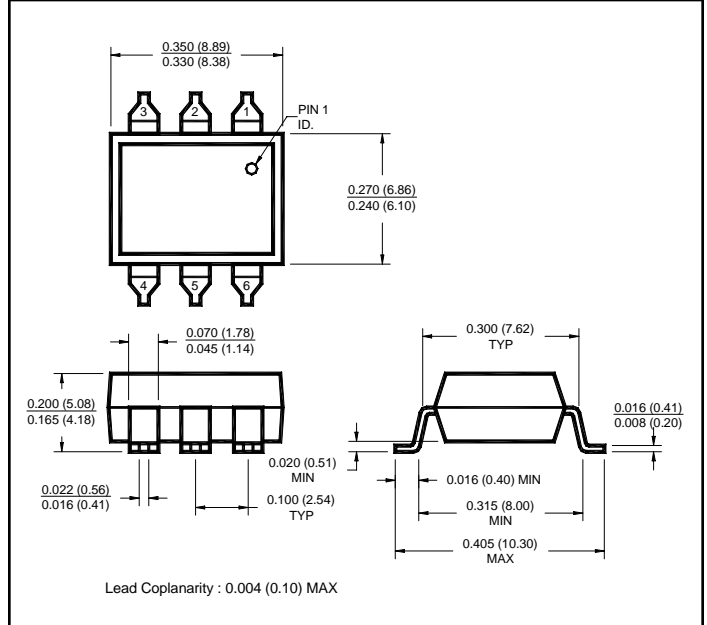

Package Dimensions (0.4" Lead Spacing)

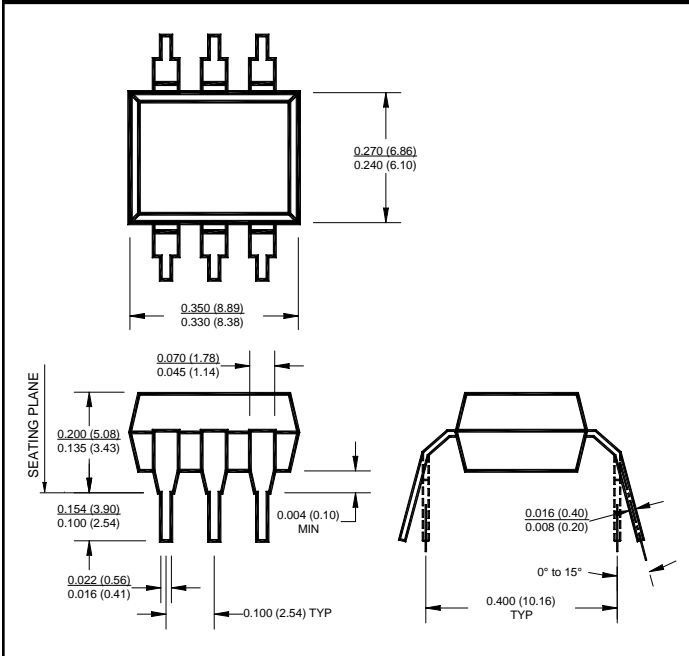

Recommended Pad Layout for Surface Mount Leadform

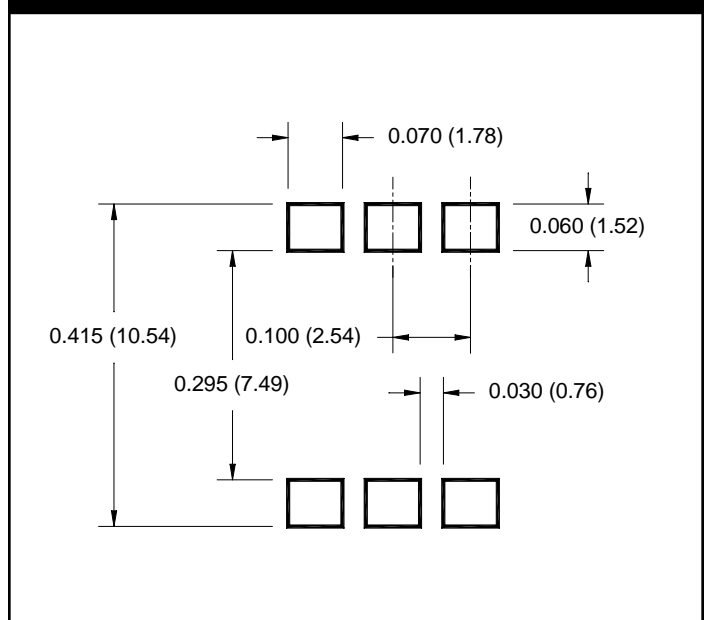

NOTE

All dimensions are in inches (millimeters)

H11AG1

H11AG2

H11AG3

Option	Order Entry Identifier	Description
S	.S	Surface Mount Lead Bend
SD	.SD	Surface Mount; Tape and reel
W	.W	0.4" Lead Spacing
300	.300	VDE 0884
300W	.300W	VDE 0884, 0.4" Lead Spacing
3S	.3S	VDE 0884, Surface Mount
3SD	.3SD	VDE 0884, Surface Mount, Tape & Reel

Carrier Tape Specifications ("D" Taping Orientation)

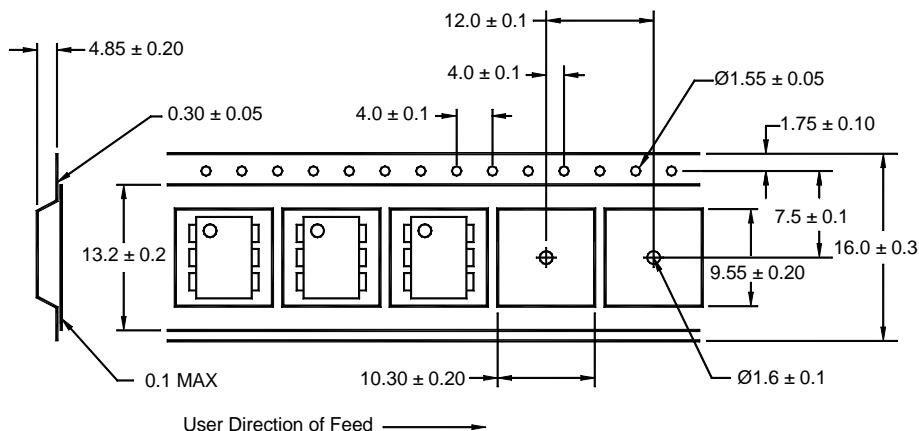

NOTE

All dimensions are millimeters

H11AG1

H11AG2

H11AG3

DISCLAIMER

FAIRCHILD SEMICONDUCTOR RESERVES THE THE RIGHT TO MAKE CHANGES WITHOUT FURTHER NOTICE TO ANY PRODUCTS HEREIN TO IMPROVE RELIABILITY, FUNCTION OR DESIGN. FAIRCHILD DOES NOT ASSUME ANY LIABILITY ARISING OUT OF THE APPLICATION OR USE OF ANY PRODUCT OR CIRCUIT DESCRIBED HEREIN; NEITHER DOES IT CONVEY ANY LICENSE UNDER ITS PATENT RIGHTS, NOR THE RIGHTS OF OTHERS.

LIFE SUPPORT POLICY

FAIRCHILD'S PRODUCTS ARE NOT AUTHORIZED FOR USE AS CRITICAL COMPONENTS IN LIFE SUPPORT DEVICES OR SYSTEMS WITHOUT THE EXPRESS WRITTEN APPROVAL OF THE PRESIDENT OF FAIRCHILD SEMICONDUCTOR CORPORATION. As used herein:

1. Life support devices or systems are devices or systems which, (a) are intended for surgical implant into the body, or (b) support or sustain life, and (c) whose failure to perform when properly used in accordance with instructions for use provided in labeling, can be reasonably expected to result in a significant injury of the user.
2. A critical component in any component of a life support device or system whose failure to perform can be reasonably expected to cause the failure of the life support device or system, or to affect its safety or effectiveness.