

## 阅读申明

- 1.本站收集的数据手册和产品资料都来自互联网，版权归原作者所有。如读者和版权方有任何异议请及时告之，我们将妥善解决。
- 2.本站提供的中文数据手册是英文数据手册的中文翻译，其目的是协助用户阅读，该译文无法自动跟随原稿更新，同时也可能存在翻译上的不当。建议读者以英文原稿为参考以便获得更精准的信息。
- 3.本站提供的产品资料，来自厂商的技术支持或者使用者的心得体会等，其内容可能存在描述上的差异，建议读者做出适当判断。
- 4.如需与我们联系，请发邮件到marketing@iczoom.com，主题请标有“数据手册”字样。

## Read Statement

1. The datasheets and other product information on the site are all from network reference or other public materials, and the copyright belongs to the original author and original published source. If readers and copyright owners have any objections, please contact us and we will deal with it in a timely manner.
2. The Chinese datasheets provided on the website is a Chinese translation of the English datasheets. Its purpose is for reader's learning exchange only and do not involve commercial purposes. The translation cannot be automatically updated with the original manuscript, and there may also be improper translations. Readers are advised to use the English manuscript as a reference for more accurate information.
3. All product information provided on the website refer to solutions from manufacturers' technical support or users the contents may have differences in description, and readers are advised to take the original article as the standard.
4. If you have any questions, please contact us at marketing@iczoom.com and mark the subject with "Datasheets" .

**DESCRIPTION**

The 4N39 and 4N40 have a gallium-arsenide infrared emitting diode optically coupled with a light activated silicon controlled rectifier in a dual in-line package.

**4N39 4N40**

**FEATURES**

- 10 A, T<sup>2</sup>L compatible, solid state relay
- 25 W logic indicator lamp driver
- 400 V symmetrical transistor coupler
- Underwriters Laboratory (UL) recognized — File #E90700

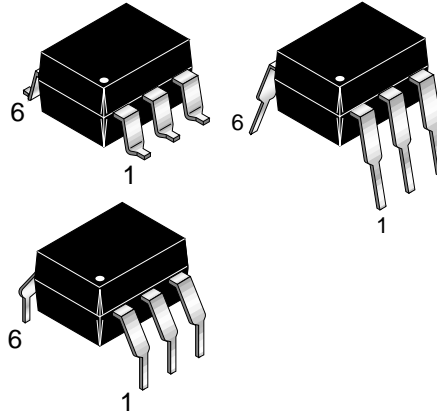

**APPLICATIONS**

- Low power logic circuits
- Telecommunications equipment
- Portable electronics
- Solid state relays
- Interfacing coupling systems of different potentials and impedances.

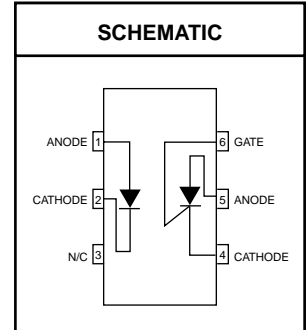

Parameter	Symbol	Device	Value	Units
<b>TOTAL DEVICE</b>				
*Storage Temperature	T <sub>STG</sub>	All	-55 to +150	°C
*Operating Temperature	T <sub>OPR</sub>	All	-55 to +100	°C
*Lead Solder Temperature	T <sub>SOL</sub>	All	260 for 10 sec	°C
*Total Device Power Dissipation (-55°C to 50 °C) Derate above 50°C	P <sub>D</sub>	All	450	mW
			9.0	mW/°C
<b>EMITTER</b>				
*Continuous Forward Current	I <sub>F</sub>	All	60	mA
*Reverse Voltage	V <sub>R</sub>	All	6	V
*Forward Current - Peak (300 μs, 2% Duty Cycle)	I <sub>F(pk)</sub>	All	1.0	A
*LED Power Dissipation (-55°C to 50 °C) Derate above 50°C	P <sub>D</sub>	All	100	mW
			2.0	mW/°C
<b>DETECTOR</b>				
*Off-State And Reverse Voltage		4N39	200	V
		4N40	400	V
*Peak Reverse Gate Voltage			6	V
*Direct On-State Current			300	mA
*Surge On-State Current (100 μs)			10	A
*Peak Gate Current			10	mA
*Detector Power Dissipation (-55°C to 50°C) Derate above 50°C	P <sub>D</sub>	All	400	mW
			8.0	mW/°C

Note

\* Indicates JEDEC Registered Data

\*\* Typical values at T<sub>A</sub> = 25°C

<b>4N39</b>	<b>4N40</b>
-------------	-------------

**ELECTRICAL CHARACTERISTICS** ( $T_A = 25^\circ\text{C}$  Unless otherwise specified.)

**INDIVIDUAL COMPONENT CHARACTERISTICS**

Parameter	Test Conditions	Symbol	Device	Min	Typ**	Max	Unit
<b>EMITTER</b>							
Input Forward Voltage	$I_F = 10\text{ mA}$	$V_F$	All		1.1	1.5	V
Reverse Leakage Current	$V_R = 3\text{ V}$	$I_R$	All			10	$\mu\text{A}$
Capacitance	$V_F = 0\text{ V}, f = 1.0\text{ MHz}$	$C_J$	All		50		pF
<b>DETECTOR</b>							
Peak Off-State Voltage	$R_{GK} = 10\text{ k}\Omega, T_A = 100^\circ\text{C}$	$V_{DM}$	4N39	200			V
			4N40	400			
Peak Reverse Voltage	$T_A = 100^\circ\text{C}$	$V_{RM}$	4N39	200			V
			4N40	400			
On-State Voltage	$I_T = 300\text{ mA}$	$V_T$	All			1.3	V
Off-State Current	$V_{DM} = 200\text{ V}, T_A = 100^\circ\text{C},$ $I_F = 0\text{ mA}, R_{GK} = 10\text{ k}\Omega$	$I_{DM}$	4N39			50	$\mu\text{A}$
			4N40			150	
Reverse Current	$V_R = 200\text{ V}, T_A = 100^\circ\text{C}, I_F = 0\text{ mA}$	$I_R$	4N39			50	$\mu\text{A}$
			4N40			150	
Holding Current	$V_{FX} = 50\text{ V}, R_{GK} = 27\text{ k}\Omega$	$I_H$	All			1.0	mA

**TRANSFER CHARACTERISTICS** ( $T_A = 25^\circ\text{C}$  Unless otherwise specified.)

Characteristics	Test Conditions	Symbol	Device	Min	Typ**	Max	Units
*Input Current to Trigger	$V_{AK} = 50\text{ V}, R_{GK} = 10\text{ k}\Omega$	$I_{FT}$	4N39			30	mA
	$V_{AK} = 100\text{ V}, R_{GK} = 27\text{ k}\Omega$		4N40			14	
*Turn-On Time	$V_{AK} = 50\text{ V}, I_F = 30\text{ mA}$ $R_{GK} = 10\text{ k}\Omega, R_L = 200\ \Omega$	$t_{on}$	ALL			50	$\mu\text{A}$
Package Capacitance (input to output)	$f = 1\text{ MHz}$ Input to Output Voltage = 0	$C_{I-O}$	ALL			2	pF
Coupled dv/dt, input to output (figure 13)		dV/dt	ALL	500			V/ $\mu\text{S}$

**ISOLATION CHARACTERISTICS**

Characteristic	Test Conditions	Symbol	Min	Typ**	Max	Units
*Input-Output Isolation Voltage	( $I_{I-O} \leq 1\ \mu\text{A}, V_{rms}, t = 1\text{ min.}$ )	$V_{ISO}$	5300			Vac(rms)
*Isolation Resistance	( $V_{I-O} = 500\text{ VDC}$ )	$R_{ISO}$	$10^{11}$			$\Omega$
Isolation Capacitance	( $V_{I-O} = \emptyset, f = 1\text{ MHz}$ )	$C_{ISO}$		0.8		pf

## Note

\* Indicates JEDEC Registered Data

 \*\* Typical values at  $T_A = 25^\circ\text{C}$

**4N39 4N40**

Figure 1. Input Current To Trigger vs. Anode-Cathode Voltage

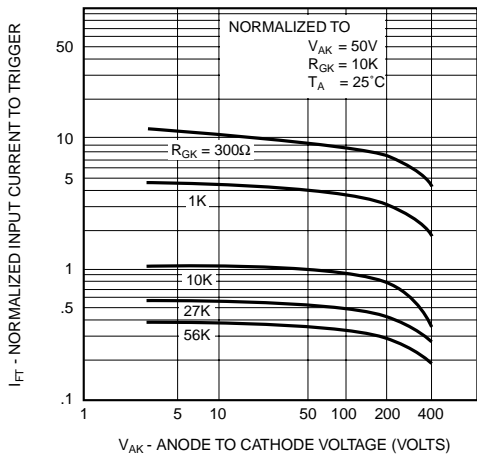

Figure 2. Input Current To Trigger vs. Temperature

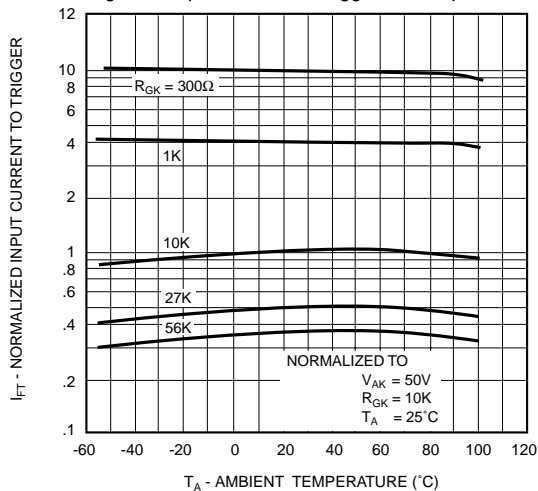

Figure 3. Input Current To Trigger Distribution vs. Temperature

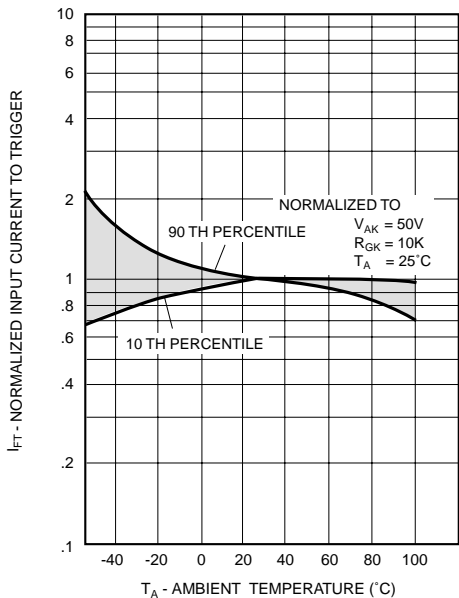

Figure 4. Input Current To Trigger vs. Pluse Width

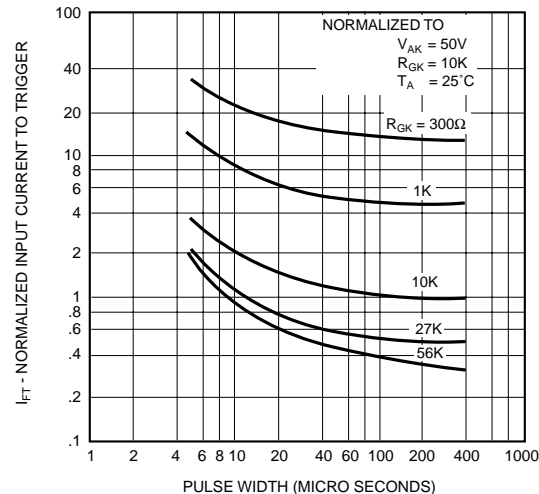

Figure 5. Turn-On Time vs. Input Current

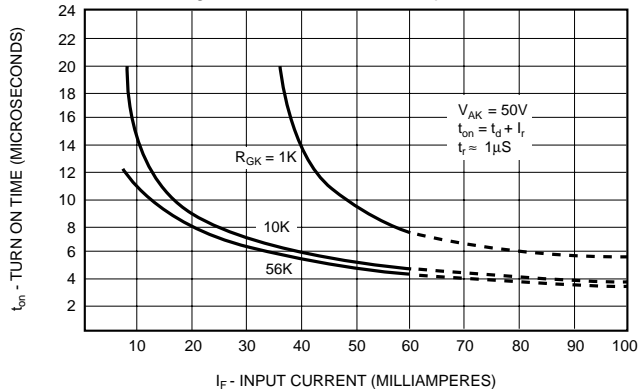
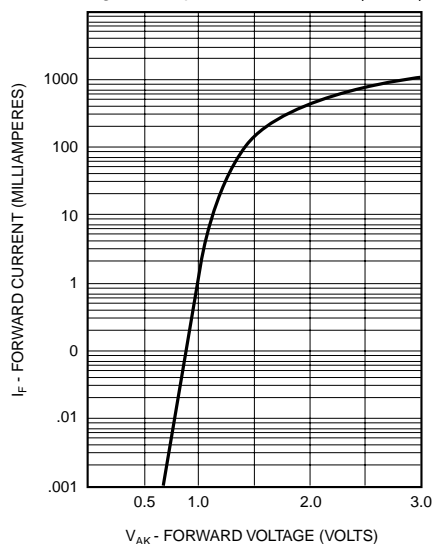

Figure 6. Input Characteristics  $I_F$  vs.  $V_F$



**4N39 4N40**

Figure 7. Holding Current vs. Temperature

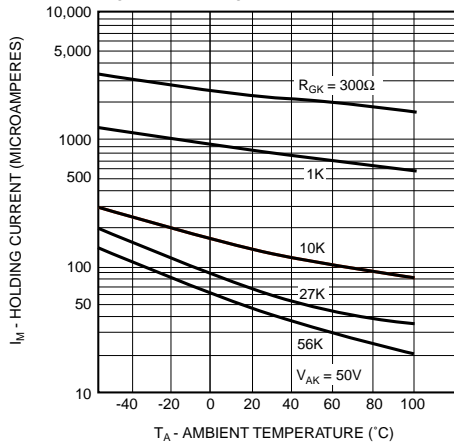

Figure 8. Maximum Transient Thermal Impedance

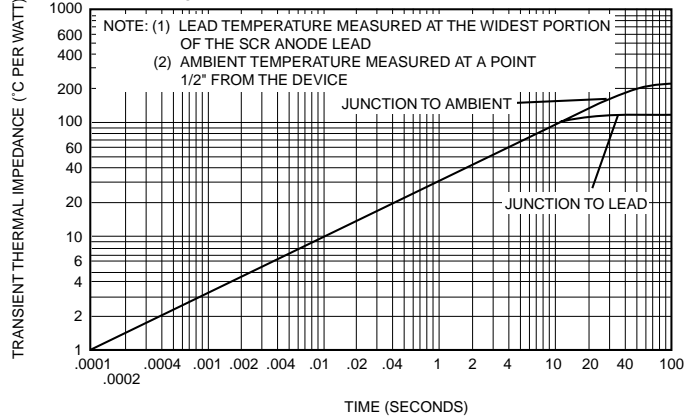

Figure 9. Off-State Forward Current vs. Temperature

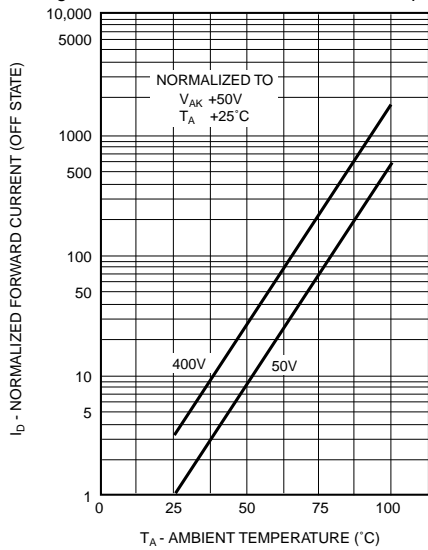

Figure 10. On-State Current vs. Maximum Allowable Temperature

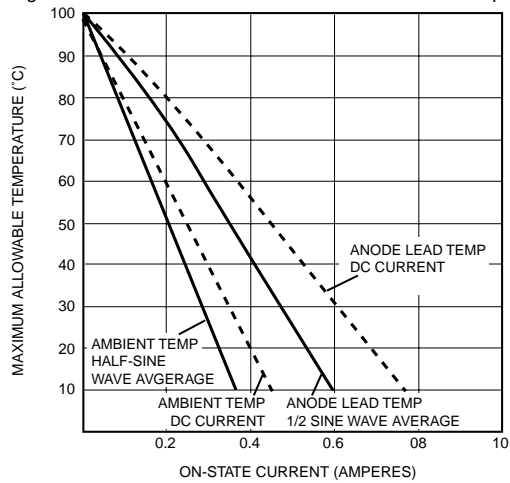

Figure 11. dv/dt vs. Temperature

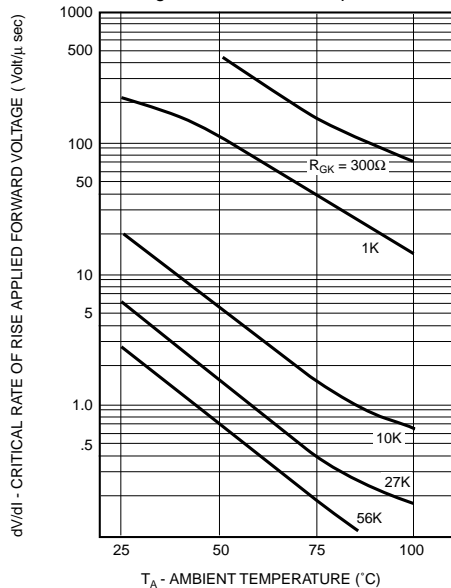
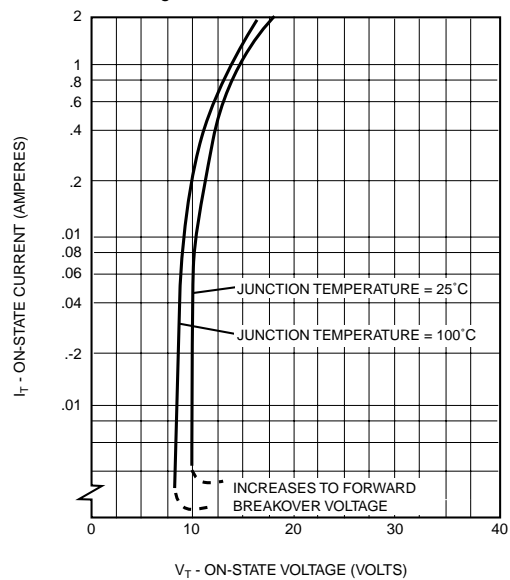
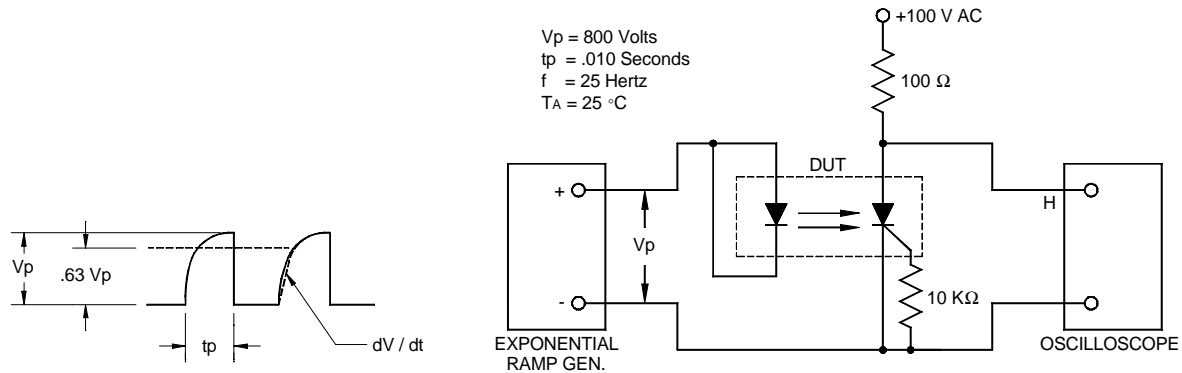

Figure 12. On-State Characteristics



**4N39 4N40**

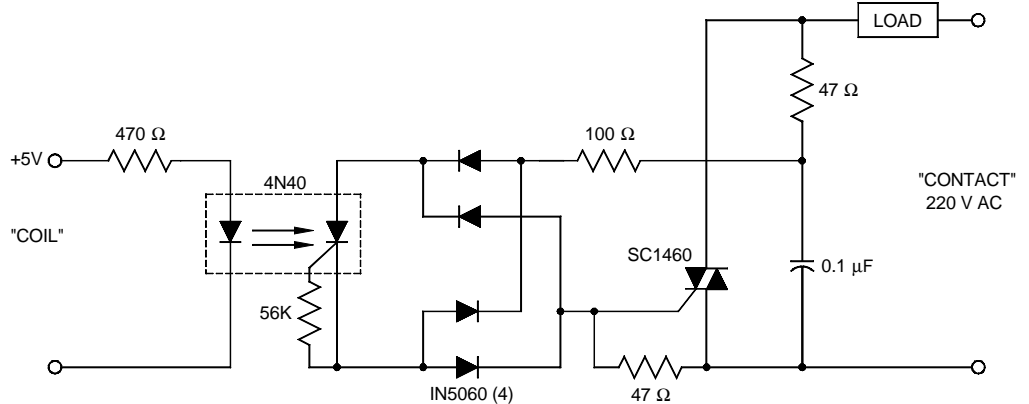

**Fig. 13 Coupled dv/dt - Test Circuit**

**TYPICAL APPLICATIONS**

**10A, T<sup>2</sup>L COMPATIBLE, SOLID STATE RELAY**

Use of the 4N40 for high sensitivity, 5300 V isolation capability, provides this highly reliable solid state relay design. This design is compatible with 74, 74S and 74H series T<sup>2</sup>L logic systems inputs and 220V AC loads up to 10A.



**25W, LOGIC INDICATOR LAMP DRIVER**

The high surge capability and non-reactive input characteristics of the 4N40 allow it to directly couple, without buffers, T<sup>2</sup>L and DTL logic to indicator alarm devices, without danger of introducing noise and logic glitches.

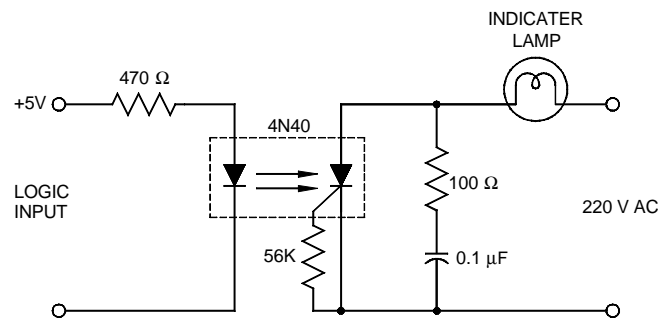

**400V SYMMETRICAL TRANSISTOR COUPLER**

Use of the high voltage PNP portion of the 4N40 provides a 400V transistor capable of conducting positive and negative signals with current transfer ratios of over 1%. This function is useful in remote instrumentation, high voltage power supplies and test equipment. Care should be taken not to exceed the 40mW power dissipation rating when used at high voltages.

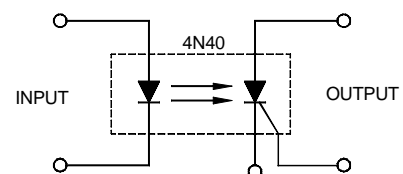

**4N39 4N40**

**Package Dimensions (Through Hole)**

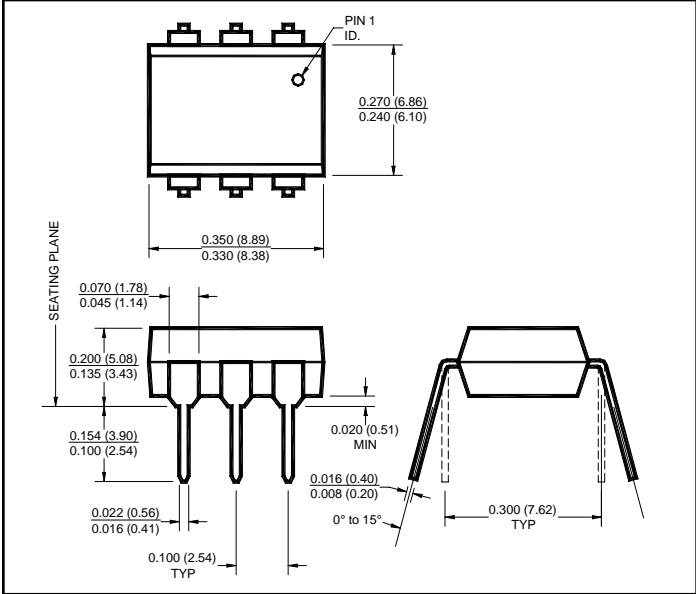

**Package Dimensions (Surface Mount)**

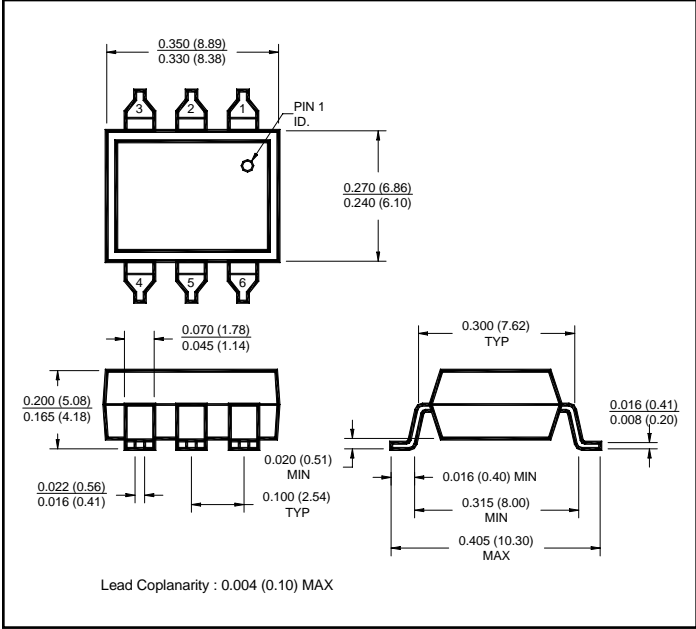

**Package Dimensions (0.4" Lead Spacing)**

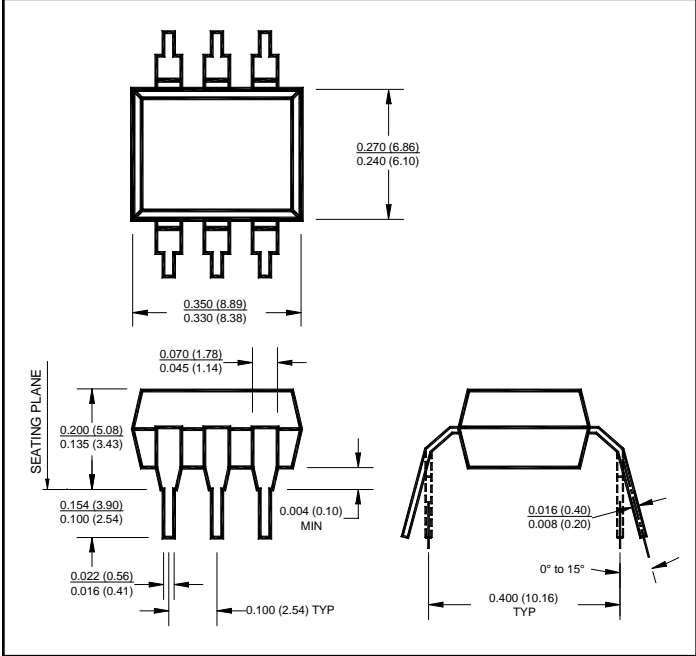

**Recommended Pad Layout for Surface Mount Leadform**

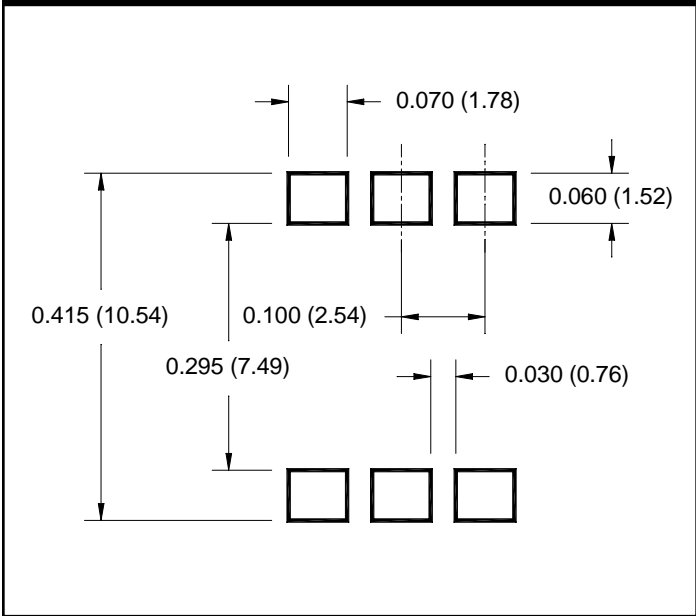

**NOTE**

All dimensions are in inches (millimeters)

**4N39 4N40**

**ORDERING INFORMATION**

Option	Order Entry Identifier	Description
S	.S	Surface Mount Lead Bend
SD	.SD	Surface Mount; Tape and reel
W	.W	0.4" Lead Spacing
300	.300	VDE 0884
300W	.300W	VDE 0884, 0.4" Lead Spacing
3S	.3S	VDE 0884, Surface Mount
3SD	.3SD	VDE 0884, Surface Mount, Tape & Reel

**Carrier Tape Specifications ("D" Taping Orientation)**

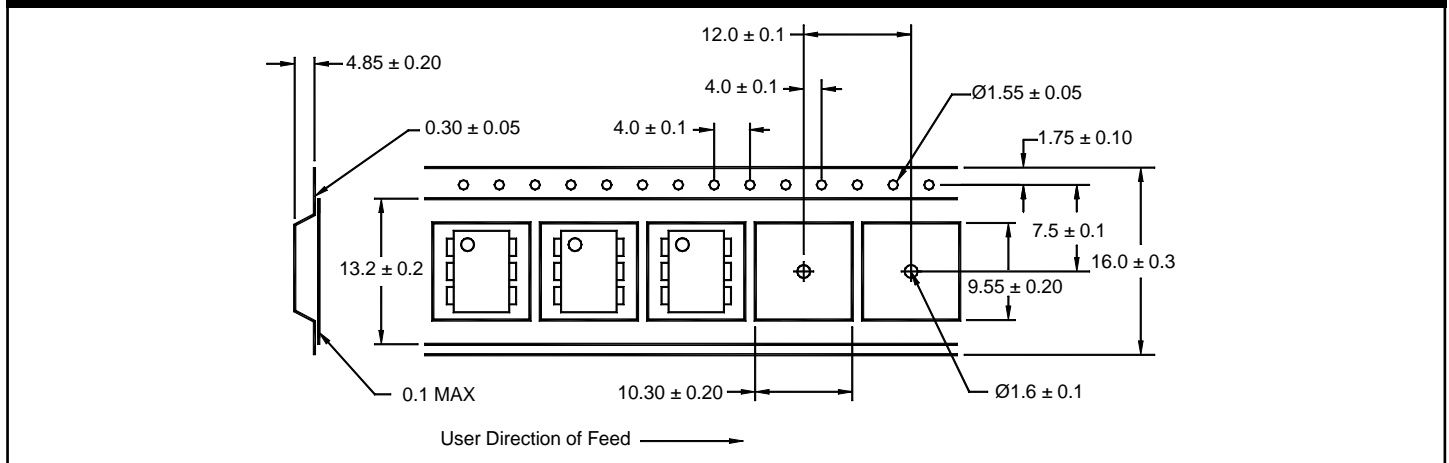

**NOTE**

All dimensions are millimeters



## DISCLAIMER

FAIRCHILD SEMICONDUCTOR RESERVES THE THE RIGHT TO MAKE CHANGES WITHOUT FURTHER NOTICE TO ANY PRODUCTS HEREIN TO IMPROVE RELIABILITY, FUNCTION OR DESIGN. FAIRCHILD DOES NOT ASSUME ANY LIABILITY ARISING OUT OF THE APPLICATION OR USE OF ANY PRODUCT OR CIRCUIT DESCRIBED HEREIN; NEITHER DOES IT CONVEY ANY LICENSE UNDER ITS PATENT RIGHTS, NOR THE RIGHTS OF OTHERS.

## LIFE SUPPORT POLICY

FAIRCHILD'S PRODUCTS ARE NOT AUTHORIZED FOR USE AS CRITICAL COMPONENTS IN LIFE SUPPORT DEVICES OR SYSTEMS WITHOUT THE EXPRESS WRITTEN APPROVAL OF THE PRESIDENT OF FAIRCHILD SEMICONDUCTOR CORPORATION. As used herein:

1. Life support devices or systems are devices or systems which, (a) are intended for surgical implant into the body, or (b) support or sustain life, and (c) whose failure to perform when properly used in accordance with instructions for use provided in labeling, can be reasonably expected to result in a significant injury of the user.
2. A critical component in any component of a life support device or system whose failure to perform can be reasonably expected to cause the failure of the life support device or system, or to affect its safety or effectiveness.