

## 阅读申明

- 1.本站收集的数据手册和产品资料都来自互联网，版权归原作者所有。如读者和版权方有任何异议请及时告之，我们将妥善解决。
- 2.本站提供的中文数据手册是英文数据手册的中文翻译，其目的是协助用户阅读，该译文无法自动跟随原稿更新，同时也可能存在翻译上的不当。建议读者以英文原稿为参考以便获得更精准的信息。
- 3.本站提供的产品资料，来自厂商的技术支持或者使用者的心得体会等，其内容可能存在描述上的差异，建议读者做出适当判断。
- 4.如需与我们联系，请发邮件到marketing@iczoom.com，主题请标有“数据手册”字样。

## Read Statement

1. The datasheets and other product information on the site are all from network reference or other public materials, and the copyright belongs to the original author and original published source. If readers and copyright owners have any objections, please contact us and we will deal with it in a timely manner.
2. The Chinese datasheets provided on the website is a Chinese translation of the English datasheets. Its purpose is for reader's learning exchange only and do not involve commercial purposes. The translation cannot be automatically updated with the original manuscript, and there may also be improper translations. Readers are advised to use the English manuscript as a reference for more accurate information.
3. All product information provided on the website refer to solutions from manufacturers' technical support or users the contents may have differences in description, and readers are advised to take the original article as the standard.
4. If you have any questions, please contact us at marketing@iczoom.com and mark the subject with "Datasheets" .

# Virtium TuffDrive™ eUSB Key SSD

## VTDU34P Product Specification

---

### 1.0 Introduction

Virtium TuffDrive™ eUSB SSDs are ideal solutions for server, networking, embedded and industrial applications that require a modest amount of storage and require a widely supported USB2.0 interface. Typical applications include operating system and file storage, system level diagnostics, or as a backup repository for data in DRAM in the event of a system-level power-down.

### 1.1 Features

- Capacities: 2GB, 4GB, 8GB, 16GB, 32GB
- Industrial SLC
- Sustained Performance
  - Read: Up to 34MB/s
  - Write: Up to 21MB/s
- Temperature
  - Commercial operating: 0°C to 70°C
  - Industrial operating: -40°C to 85°C
  - Non-operating: -55°C to 95°C
- Power: 5V
  - Maximum: mW (5V)
  - Idle: 340 mW (5V)
- Reliability
  - MTBF: 5,000,000 hours
  - SLC NAND endurance 60K @ 55°C
- Compliance
  - USB 2.0
  - RoHS
  - CE and FCC
- Operating Systems supported: Windows 7, Vista, XP, 200, ME, 98/98SE, and Mac OS 9.x and above, Linux Kernel 2.4 and above
- Supports unique VID, PID, and serial number
- Form Factor Type – A connector
- Mechanical Dimensions - L x W x H mm (inches)
  - 45.35 (1.785) x 17.90 (0.705) x 6.20 (0.244)
- Weight
  - 5 +/- 0.1 g
- Environmental (Operating/non-operating):
  - MIL-STD-810F
  - Shock: 1500g, 0.5ms duration
  - Vibration: 16.4G<sub>RMS</sub>





<b>Product Specification</b>	
<b>TuffDrive eUSB Key SSD</b> VTDU34PxxxxG-xxx	<b>Rev: 0.8</b>

## 2.0 Ordering Information and Part Numbering System

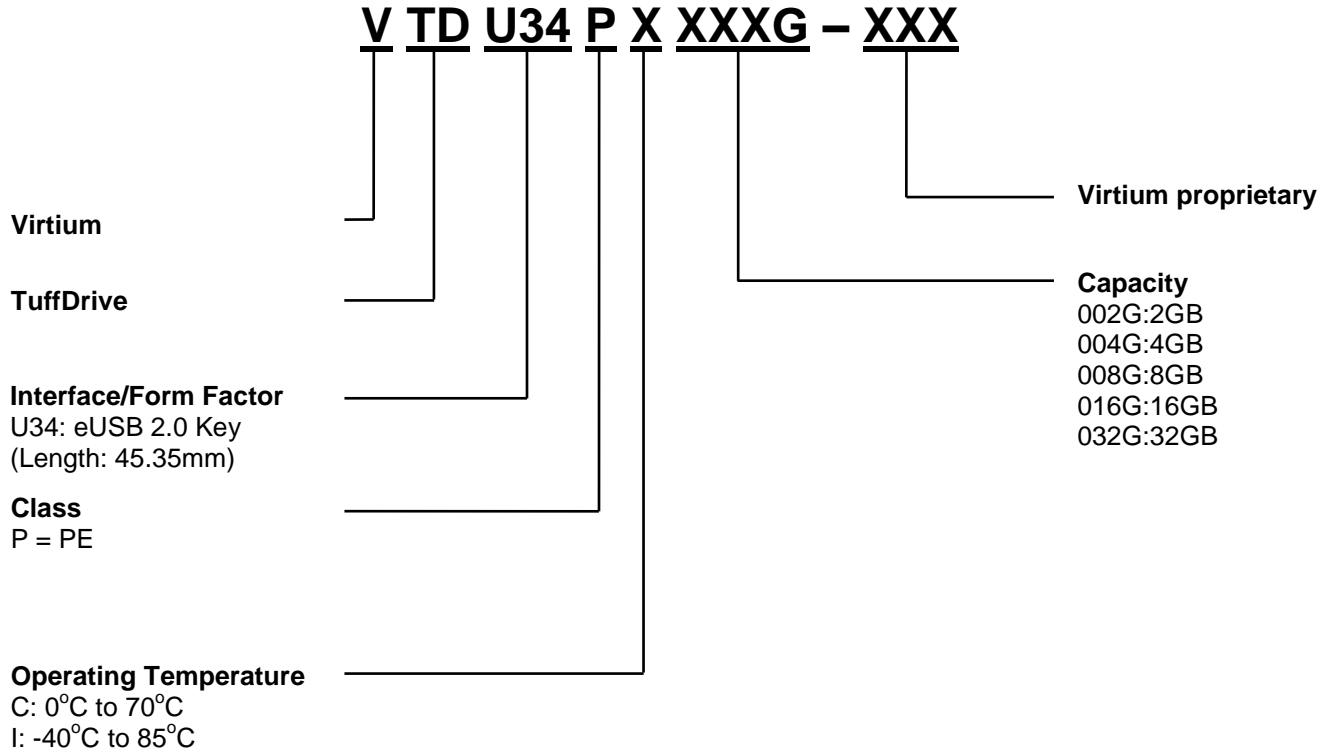



<b>Product Specification</b>	
<b>TuffDrive eUSB Key SSD</b> VTDU34PxxxxG-xxx	<b>Rev: 0.8</b>

### 3.0 Table of Contents

1.0	Introduction .....	1
2.0	Ordering Information and Part Numbering System .....	2
3.0	Table of Contents .....	3
4.0	Specifications .....	4
4.1	Capacity .....	4
4.2	Performance .....	4
4.3	Environmental Specifications .....	4
4.3.1	Temperature and Humidity .....	4
4.3.2	Shock and Vibration .....	5
4.4	Mean Time Between Failures (MTBF) .....	5
4.5	Power Requirements .....	5
4.6	Certifications and Compliance .....	5
5.0	Physical Specification .....	Error! Bookmark not defined.
5.1	Pin Assignments .....	Error! Bookmark not defined.
5.2	Mechanical Dimensions .....	9
6.0	Revision History .....	10

### List of Tables

TABLE 1: TUFFDRIVE EUSB CAPACITY .....	4
TABLE 2: READ/WRITE PERFORMANCE .....	4
TABLE 3: TEMPERATURE AND HUMIDITY .....	4
TABLE 4: SHOCK AND VIBRATION .....	5
TABLE 5: POWER CONSUMPTION .....	5
TABLE 7: CERTIFICATIONS AND COMPLIANCE .....	6
TABLE 7: PIN ASSIGNMENTS .....	ERROR! BOOKMARK NOT DEFINED.

### List of Figures

FIGURE 1: 10-PIN SOCKET PINOUT .....	ERROR! BOOKMARK NOT DEFINED.
FIGURE 2: MECHANICAL DIMENSIONS .....	9



<b>Product Specification</b>	
<b>TuffDrive eUSB Key SSD</b> <b>VTDU34PxxxxG-xxx</b>	<b>Rev: 0.8</b>

## 4.0 Specifications

### 4.1 Capacity

**Table 1: TuffDrive eUSB capacity**

Unformatted Capacity (GB) <sup>(1)</sup>	User-Addressable LBA <sup>(2)</sup>	User-Addressable Capacity Bytes
2	3,907,670	2,000,727,040
4	7,815,339	4,001,453,568
8	15,630,678	8,002,907,136
16	31,261,356	16,005,814,272
32	62,522,712	32,011,628,544

(1) 1GB = 1,000,000,000 bytes

(2) LBA: Logical Block Address. Logical block size of 512 bytes (1 sector)

### 4.2 Performance

**Table 2: Read/Write Performance<sup>(1)</sup>**

Transfer Rate	Value	Units
Sustained Read (max) >= 8GB	34	MB/s
Sustained Write (max) >= 8GB	21	MB/s
Sustained Read (max) 4GB	27	MB/s
Sustained Write (max) 4GB	16.5	MB/s
Sustained Read (max) 2GB	25	MB/s
Sustained Write (max) 2GB	16.5	MB/s

(1) CrystalDiskMark 3.0.3

### 4.3 Environmental Specifications

#### 4.3.1 Temperature and Humidity

**Table 3: Temperature and Humidity**

P/N	Operating Temperature (°C)	Non-Operating Temperature (°C) & Moisture Sensitivity
VTDU34PCxxxG-xxx	0°C to 70°C	-65°C to +95°C 5% to 95% (non-condensing)
VTDU34PIxxxG-xxx	-40°C to 85°C	

### 4.3.2 Shock and Vibration

**Table 4: Shock and Vibration**

Reliability	Test Conditions
Shock <sup>(1)</sup>	1500G, ½ sine, 0.5ms duration
Vibration <sup>(2)</sup>	16.4G <sub>RMS</sub>

(1) MIL-STD-810F, Method 516.5

(2) MIL-STD-810F, Method 514.5

### 4.4 Mean Time Between Failures (MTBF)

Virtium’s TuffDrive eUSB achieves a MTBF of 5,000,000 hours predicted based on the component reliability data using Telcordia SR-332 methods at 40°C.

### 4.5 Power Requirements

5V single power supply operation.

**Table 5: Power Consumption**

Voltage	Maximum <sup>(1)</sup>	Typical <sup>(2)</sup>	Idle
5V	585 mW	404 mW	390 mW

(1) Max power consumption measured on > 8GB , 100% 64KB sequential writes

(2) 70/30 read/write workload

### 4.6 S.M.A.R.T. Attributes

The following table defines the current Virtium SMART data attributes that are supported.

Customers may view this data using the Linux SMARTmontools package. This package and the associated **smartctl** command should be used with options **-a**, **-i**, and **-d sat** for best viewing. The command `$ smartctl -d sat -a -i /dev/sdb` was used to retrieve the data below.

Attribute ID	Attribute Name	Attribute Description
0x0C	Power Cycle Count	Number of Power On cycles
0xC4	Spare block count	The amount of available spare blocks. Attribute value. The value returned here is the percentage of remaining spare blocks summed over all flash chips, i.e.(100 × current spare blocks / initial spare blocks)
0xE5	Erase count	The value returned here is an estimation of the remaining card life, in percent, based on the number of flash block



<b>Product Specification</b>	
<b>TuffDrive eUSB Key SSD VTDU34PxxxxG-xxx</b>	<b>Rev: 0.8</b>

Attribute ID	Attribute Name	Attribute Description
		erases compared to the target number of erase cycles per block.
0xCB	ECC Error Count	Total number of ECC errors correctable and uncorrectable for the NAND data.
0xCC	Number of corrected ECC errors	The total number of correctable ECC errors that have occurred on flash read commands.
0xE8	Number of Reads	The total number of flash read commands.
0xF1	Total LBAs Written	Total number of LBAs written to the disk, divided by 65536
0xF2	Total LBAs Read	Total number of LBAs read from the disk, divided by 65536

## 4.7 Certifications and Compliance

**Table 6: Certifications and Compliance**

Compliance/Certification	Description
CE and FCC Compliant	Class: FCC Part 15 Subpart B Class B:2011 Declaration of Conformity registration No. STE120607699
RoHS Compliant	Restriction of Hazardous Substance Directive
UL Certified	Underwriters Laboratories, Inc. 94V-0
WEEE Certified	Waste, Electrical and Electronic Equipment Directive

## 5.0 Physical Specification

### 5.1 Pin Assignments

**Table 7: Pin Assignments**

Pins	Type	Description
1	VBUS (+5V)	Input Power
2	D -	Differential Data (-)
3	D +	Differential Data (+)
4	GND	Ground

Product Specification	
TuffDrive eUSB Key SSD VTDU34PxxxxG-xxx	Rev: 0.8

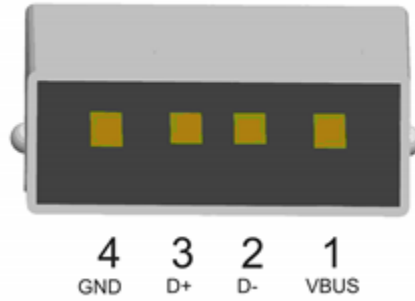

USB 2.0 pinout

**Figure 1: The standard USB type-A plug pinout**





<b>Product Specification</b>	
<b>TuffDrive eUSB Key SSD VTDU34PxxxxG-xxx</b>	<b>Rev: 0.8</b>

<b>Product Specification</b>	
<b>TuffDrive eUSB Key SSD</b> VTDU34PxxxxG-xxx	<b>Rev: 0.8</b>

## 5.2 Mechanical Dimensions

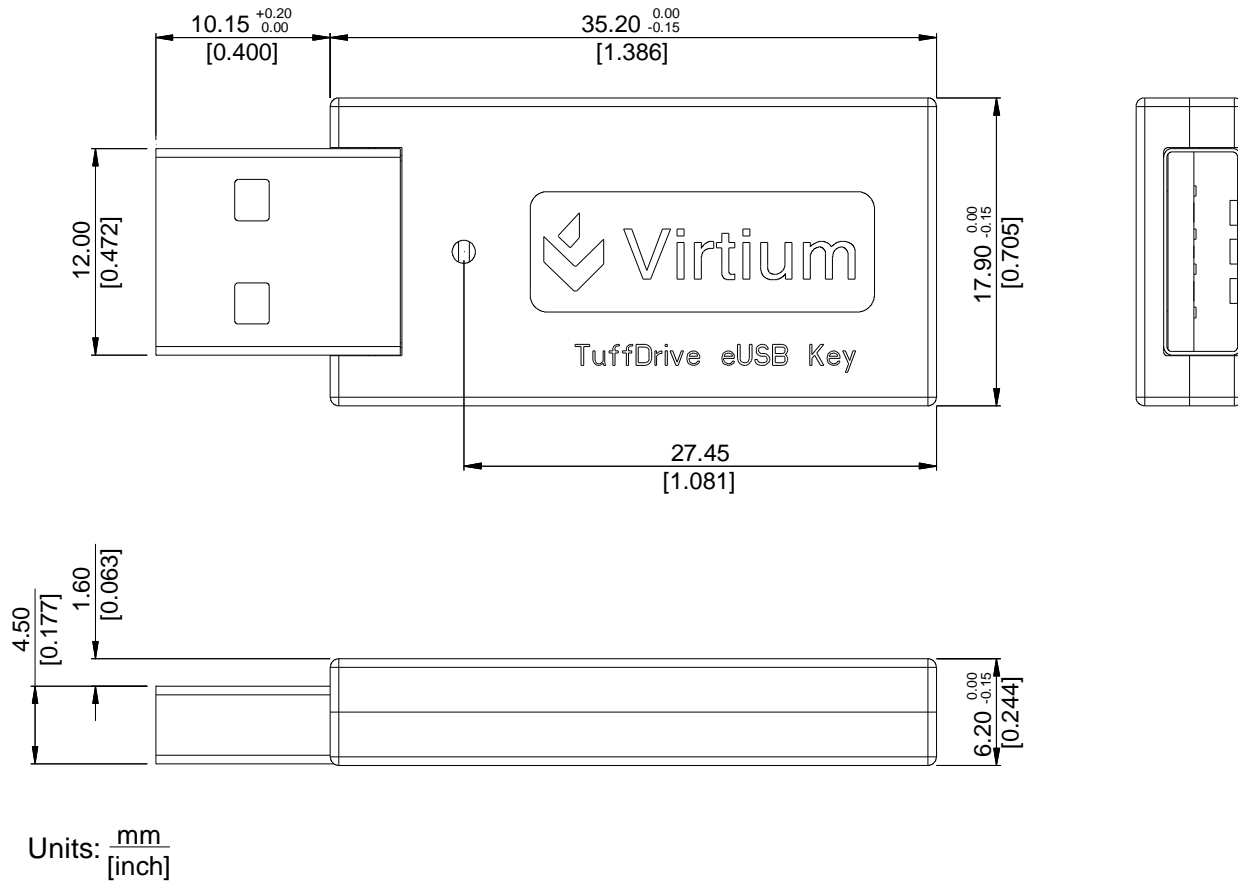

Figure 2: Mechanical Dimensions



<b>Product Specification</b>	
<b>TuffDrive eUSB Key SSD</b> VTDU34PxxxxG-xxx	<b>Rev: 0.8</b>

## 6.0 Revision History

Date	Rev.	Page	Changes
2/6/2015	08	All	Initial Release – Priliminary SVN 3198