

## 阅读申明

- 1.本站收集的数据手册和产品资料都来自互联网，版权归原作者所有。如读者和版权方有任何异议请及时告之，我们将妥善解决。
- 2.本站提供的中文数据手册是英文数据手册的中文翻译，其目的是协助用户阅读，该译文无法自动跟随原稿更新，同时也可能存在翻译上的不当。建议读者以英文原稿为参考以便获得更精准的信息。
- 3.本站提供的产品资料，来自厂商的技术支持或者使用者的心得体会等，其内容可能存在描述上的差异，建议读者做出适当判断。
- 4.如需与我们联系，请发邮件到marketing@iczoom.com，主题请标有“数据手册”字样。

## Read Statement

1. The datasheets and other product information on the site are all from network reference or other public materials, and the copyright belongs to the original author and original published source. If readers and copyright owners have any objections, please contact us and we will deal with it in a timely manner.
2. The Chinese datasheets provided on the website is a Chinese translation of the English datasheets. Its purpose is for reader's learning exchange only and do not involve commercial purposes. The translation cannot be automatically updated with the original manuscript, and there may also be improper translations. Readers are advised to use the English manuscript as a reference for more accurate information.
3. All product information provided on the website refer to solutions from manufacturers' technical support or users the contents may have differences in description, and readers are advised to take the original article as the standard.
4. If you have any questions, please contact us at marketing@iczoom.com and mark the subject with "Datasheets" .

---

# DataSheet

---

OMNUC G5-Series System Configuration .....	2
AC Servomotors / Servo Drives with Built-in EtherCAT Communications..	2
AC Servo Drives (EtherCAT Communications) .....	4
Contents	
Ordering Information	
Specifications	
Components and Functions	
Dimensions	
AC Servomotors R88M-K .....	11
Contents	
Ordering Information	
Specifications	
Dimensions	
Ordering Information .....	31
Interpreting Model Numbers .....	32
■ Servo Drive Model Numbers	
■ Servomotor Model Numbers	
■ Understanding Decelerator Model Numbers (Backlash = 3' Max./Backlash = 15' Max.)	
Table of Servomotor Variations.....	34
Ordering Information .....	35
AC Servo Drives (EtherCAT Communications)	
Servomotors	
Decelerators (Backlash = 3' Max./Backlash = 15' Max.)	
Accessories and Cables	
Combination table .....	45
■ Servo Drive and Servomotor Combinations	
■ Servomotor and Decelerator Combinations	
■ Cable Combinations	
About Manuals.....	50
Read and Understand this Catalog	

# R88M-K/R88D-KN□-ECT-R

## System Configuration

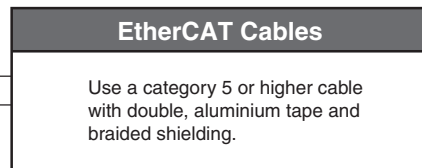
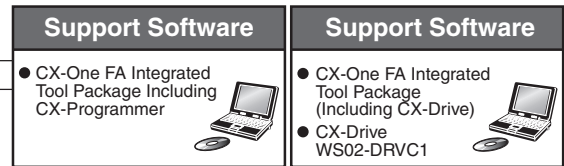
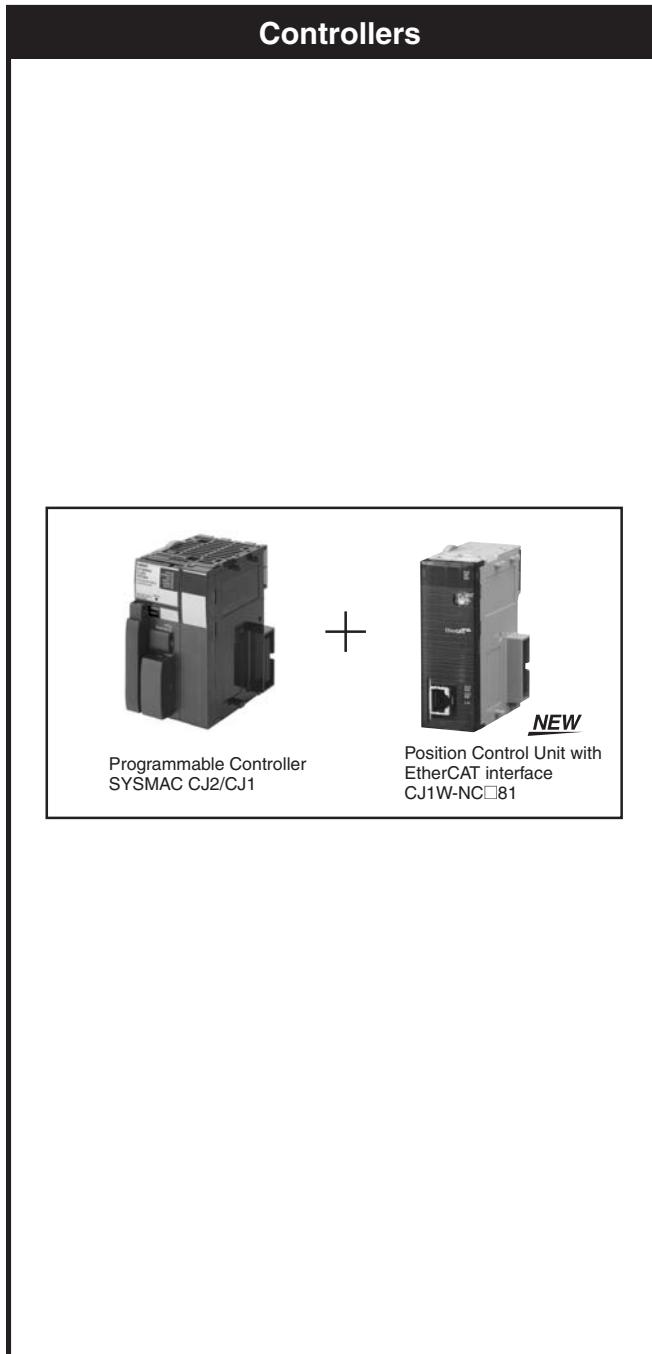

# High-Speed and High-Precision OMNUC G5 Series EtherCAT Communications with the Controller

- High-accuracy positioning with fully-closed control.
- Servo Drives for 400VAC widens applicable systems and environment, including large-scale equipment and overseas facilities.
- Safe design and Safe Torque Off (STO) function (application pending)
- Vibration can be suppressed in acceleration/deceleration even in low-rigidity mechanical systems.



OMNUC G5-Series  
System Configuration

AC Servo Drives with Built-in  
EtherCAT Communications

Servomotors

Ordering Information

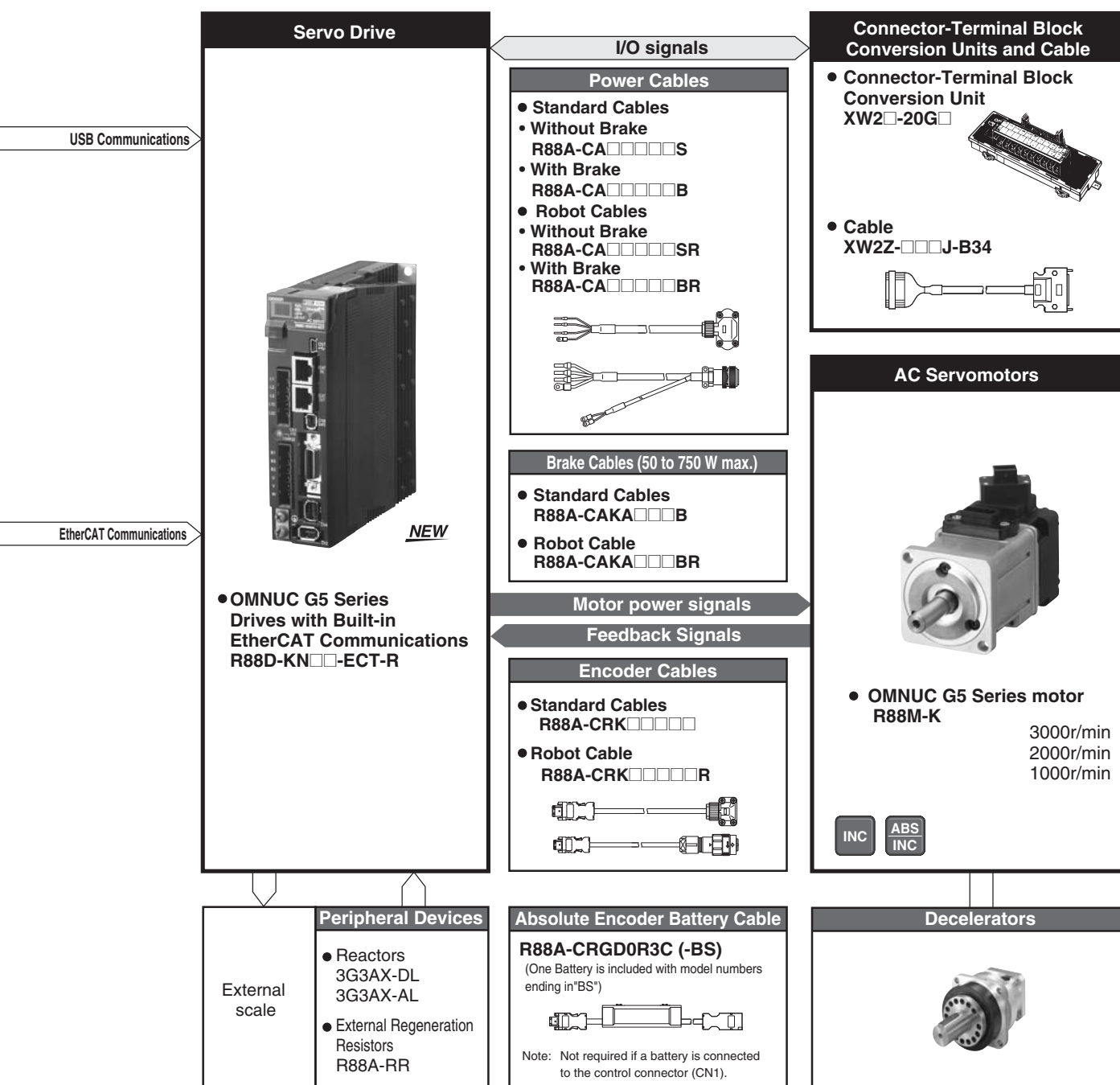

USB Communications

EtherCAT Communications

# OMNUC G5-series AC Servo Drives with Built-in EtherCAT Communications

# R88D-KN□-ECT-R

## Contents

- Ordering Information
- Specifications
  - General Specifications
  - Characteristics
    - Servo Drives with Single-phase 100 VAC Input Power
    - Servo Drives with Single-phase or Three-phase 200 VAC Input Power
    - Servo Drives with Three-phase 400 VAC Input Power
  - EtherCAT Communication Specifications
- Names and Functions
  - Servo Drive Part Names
  - Functions
- Dimensions



**NEW**



## Ordering Information

Refer to the Ordering Information.

## Specifications

### General Specifications

Item		Specifications	
Ambient operating temperature and operating humidity		0 to 55°C, 90%RH max. (with no condensation)	
Storage ambient temperature and humidity		-20 to 65°C, 90%RH max. (with no condensation)	
Operating and storage atmosphere		No corrosive gases	
Vibration resistance		10 to 60 Hz and at an acceleration of 5.88 m/s <sup>2</sup> or less (Not to be run continuously at a resonance point)	
Insulation resistance		Between power supply terminals/power terminals and FG terminal: 0.5 MΩ min. (at 500 VDC)	
Dielectric strength		Between power supply/power line terminals and FG terminal: 1,500 VAC for 1 min at 50/60 Hz	
Protective structure		Built into panel	
International standard	EC Directives	EMC Directive	EN 55011, EN 61000-6-2, IEC 61800-3
		Low Voltage Directive	EN 61800-5-1
	UL standards		UL 508C
	CSA standards		CSA22.2 No. 14
Functional safety (application pending)		EN 954-1, ISO 13849-1, EN 61508, EN 62061 and IEC 61800-5-2, and IEC 61326-3-1	

- Note:**
1. The above items reflect individual evaluation testing. The results may differ under compound conditions.
  2. Never perform dielectric strength or other megameter tests on the Servo Drive. Failure to follow this guideline may result in damaging the internal elements.
  3. Depending on the operating conditions, some Servo Drive parts will require maintenance. For details, refer to Users Manual (I573).

## Characteristics

### ● Servo Drives with 100 VAC Input Power for Single-phase input type

Item			R88D-KNA5L-ECT-R	R88D-KN01L-ECT-R	R88D-KN02L-ECT-R	R88D-KN04L-ECT-R
Continuous output current (rms)			1.2 A	1.7 A	2.5 A	4.6 A
Input power supply	Main circuit	Power supply capacity	0.4 KVA	0.4 KVA	0.5 KVA	0.9 KVA
		Power supply voltage	Single-phase 100 to 120 VAC (85 to 132 V) 50/60 Hz			
		Rated current	1.4 A	2.6 A	4.3 A	7.6 A
	Control circuit	Power supply voltage	Single-phase 100 to 120 VAC (85 to 132 V) 50/60 Hz			
Control method			All-digital servo			
Inverter method			IGBT-driven PWM			
PWM frequency			12.0 kHz		6.0 kHz	
Weight			Approx. 0.8 kg	Approx. 0.8 kg	Approx. 1.0 kg	Approx. 1.6 kg
Maximum applicable motor capacity			50 W	100 W	200 W	400 W
Applicable Servomotor	3,000 r/min Servomotors	<b>INC</b>	K05030H	K10030L	K20030L	K40030L
		<b>ABS</b>	K05030T	K10030S	K20030S	K40030S
	2,000 r/min Servomotors	<b>ABS</b>	-	-	-	-
		<b>ABS</b>	-	-	-	-

### ● Servo Drives with 200 VAC Input Power for Single-phase/Three-phase input type

Item			R88D-KN01H-ECT-R	R88D-KN02H-ECT-R	R88D-KN04H-ECT-R	R88D-KN08H-ECT-R	R88D-KN10H-ECT-R	R88D-KN15H-ECT-R
Continuous output current (rms)			1.2 A	1.6 A	2.6 A	4.1 A	5.9 A	9.4 A
Input power supply	Main circuit	Power supply capacity	0.5 KVA	0.5 KVA	0.9 KVA	1.3 KVA	1.8 KVA	2.3KVA
		Power supply voltage	Single-phase or 3-phase 200 to 240 VAC (170 to 264 V) 50/60 Hz					
		Rated current	1.3 A	2.4/1.3 A*1	4.1/2.4 A*1	6.6/3.6 A*1	9.1/5.9 A*1	14.2/8.1 A*1
	Control circuit	Power supply voltage	Single-phase 200 to 240 VAC (170 to 264 V) 50/60 Hz					
PWM frequency			12.0 kHz			6.0 kHz		
Weight			Approx. 0.8 kg	Approx. 0.8 kg	Approx. 1.0 kg	Approx. 1.6 kg	Approx. 1.8 kg	Approx. 1.8 kg
Maximum applicable motor capacity			100 W	200 W	400 W	750 W	1 kW	1.5 kW
Applicable Servomotor	3,000 r/min Servomotors	<b>INC</b>	K05030H K10030H	K20030H	K40030H	K75030H	-	K1K030H K1K530H
		<b>ABS</b>	K05030T K10030T	K20030T	K40030T	K75030T	-	K1K030T K1K530T
	2,000 r/min Servomotors	<b>INC</b>	-	-	-	-	K1K020H	K1K520H
		<b>ABS</b>	-	-	-	-	K1K020T	K1K520T
	1,000 r/min Servomotors	<b>INC</b>	-	-	-	-	-	K90010H
		<b>ABS</b>	-	-	-	-	-	K90010T
Control method			All-digital servo					
Inverter method			IGBT-driven PWM					

\*1. The first value is for single-phase input power and the second value is for 3-phase input power.

## ● Servo Drives with 400 VAC Input Power for Three-phase input type

Item			R88D-KN06F-ECT-R	R88D-KN10F-ECT-R	R88D-KN15F-ECT-R
Continuous output current (rms)			2.9 A	2.9 A	4.7 A
Input power supply	Main circuit	Power supply voltage	Three-phase 380 to 480 VAC (323 to 528 V) 50/60 Hz		
		Rated current	2.8 A	2.8 A	4.7 A
	Control circuit	Power supply voltage	24 VDC (20.4 to 27.6 V)		
PWM frequency			6.0 kHz		
Weight			Approx. 1.9 kg	Approx. 1.9 kg	Approx. 1.9 kg
Maximum applicable motor capacity			600 W	1 kW	1.5 kW
Applicable Servomotor	3,000 r/min Servomotors	<b>INC</b>	–	K75030F	K1K030F K1K530F
		<b>ABS</b>	–	K75030C	K1K030C K1K530C
	2,000 r/min Servomotors	<b>INC</b>	K40020F K60020F	K1K020F	K1K520F
		<b>ABS</b>	K40020C K60020C	K1K020C	K1K520C
	1,000 r/min Servomotors	<b>INC</b>	–	–	K90010F K90010C
			–	–	
Control method			All-digital servo		
Inverter method			IGBT-driven PWM		

## EtherCAT Communications Specifications

Item	Specification
Communications standard	IEC 61158 Type 12, IEC 61800-7 CiA 402 Drive Profile
Physical layer	100BASE-TX (IEEE802.3)
Connectors	RJ45 × 2 ECAT IN: EtherCAT input ECAT OUT: EtherCAT output
Communications media	Category 5 or higher (cable with double, aluminum tape and braided shielding) is recommended.
Communications distance	Distance between nodes: 100 m max.
Process data	Fixed PDO mapping
Mailbox (CoE)	Emergency messages, SDO requests, SDO responses, and SDO information
Distributed clock	Synchronization in DC mode. DC cycle: 250 μs, 500 μs, 1 ms, 2 ms, 4 ms
LED indicators	L/A IN (Link/Activity IN) × 1 L/A OUT (Link/Activity OUT) × 1 RUN × 1 ERR × 1
CiA402 Drive Profile	<ul style="list-style-type: none"> <li>• Cyclic synchronous position mode</li> <li>• Touch probe function (Latch function)</li> <li>• Torque limit function</li> </ul>

## Components and Functions

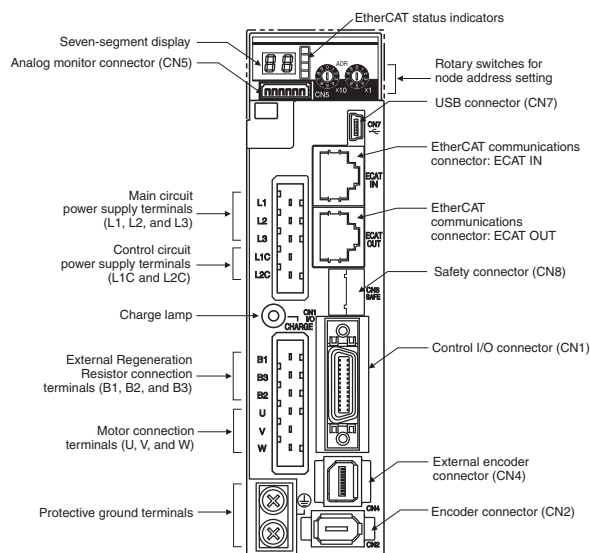

### Display

A 2-digit 7-segment display shows the node address, error codes, and other Servo Drive status.

### Charge Lamp

Lights when the main circuit power supply is turned ON.

### EtherCAT Status Indicators

These indicators show the status of EtherCAT communications. For details, refer to Users Manual (I573).

### Control I/O Connector (CN1)

Used for command input signals and I/O signals.

### Encoder Connector (CN2)

Connector for the encoder installed in the Servomotor.

### External Encoder Connector (CN4)

Connector for an encoder signal used during fully-closed control.

### EtherCAT Communications Connectors (ECAT IN and ECAT OUT)

These connectors are for EtherCAT communications.

### Analog Monitor Connector (CN5)

You can use a special cable to monitor values, such as the motor rotation speed, torque command value, etc.

### USB Connector (CN7)

Communications connector for the computer.

### Safety Connector (CN8)

Connector for safety devices.

If no safety devices are used, keep the factory-set safety bypass connector installed.

## EtherCAT Communications Connector

This connector is used to connect the EtherCAT twisted-pair cable.

## Connector Specifications

Specification	Description
Electrical characteristics	Conforms to IEEE 802.3 standards.
Connector structure	RJ45 8-pin modular connector (Conforms to ISO 8877.)

## Pin Assignments

	Pin No.	Signal name	Abbreviation	Signal direction
	1	Transmission data +	TD+	Output
	2	Transmission data -	TD-	Output
	3	Reception data +	RD+	Input
	4	Not used.	—	—
	5	Not used.	—	—
	6	Reception data -	RD-	Input
	7	Not used.	—	—
	8	Not used.	—	—
	Hood	Frame ground	FG	—

## EtherCAT Communications Cables

Use a category 5 or higher cable with double, aluminum tape and braided shielding.

**Note:** The maximum distance between any two nodes is 100 m. Some cables, however, are not rated for 100 m. Generally speaking, the transmission performance of stranded wires is worse than that of solid wire. Cables with stranded wires generally are not rated for 100 m.

## Connector (Modular Plug) Specifications

Use a category 5 or higher, shielded connector.

**Note:** When selecting a connector, make sure that it is suitable for the cable that you are using. The following items must be confirmed: conductor size, whether connector is solid or stranded wire, whether there are 2 wire pairs or 4, the outside diameter, etc.



## Functions

### Basic control

Position control	Fully closed control
------------------	----------------------

### Advanced control

Vibration control	Gain switching	Friction torque compensation function
Adaptive filter	Torque limit	Inertia ratio switching function
Notch filter	Sequence I/O signal	Hybrid Vibration Suppression Function
Electronic gear function	Forward and reverse drive prohibition functions	Feed-forward function
Encoder dividing function	Disturbance observer function	Instantaneous speed observer function
Brake interlock	Gain switching 3 function	

### Other functions

#### Safe Torque OFF (STO) Function (application pending)

#### Realtime autotuning

#### Manual tuning

#### Various parameters

Basic Parameters	Interface Monitor Setting Parameters
Gain Parameters	Extended Parameters
Vibration Suppression Parameters	Special Parameters
Analog Control Parameters	

## Dimensions

### <Wall Mounting>

Single-phase 100 VAC R88D-KNA5L-ECT-R/-KN01L-ECT-R (50 to 100 W)

Single-phase/Three-phase 200 VAC R88D-KN01H-ECT-R/-KN02H-ECT-R (100 to 200W)

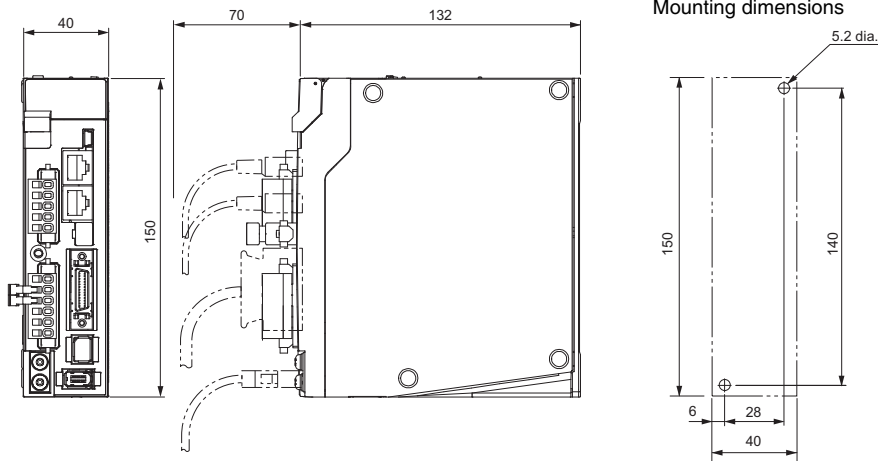

Single-phase 100 VAC R88D-KN02L-ECT-R (200W)

Single-phase/Three-phase 200 VAC R88D-KN04H-ECT-R (400W)

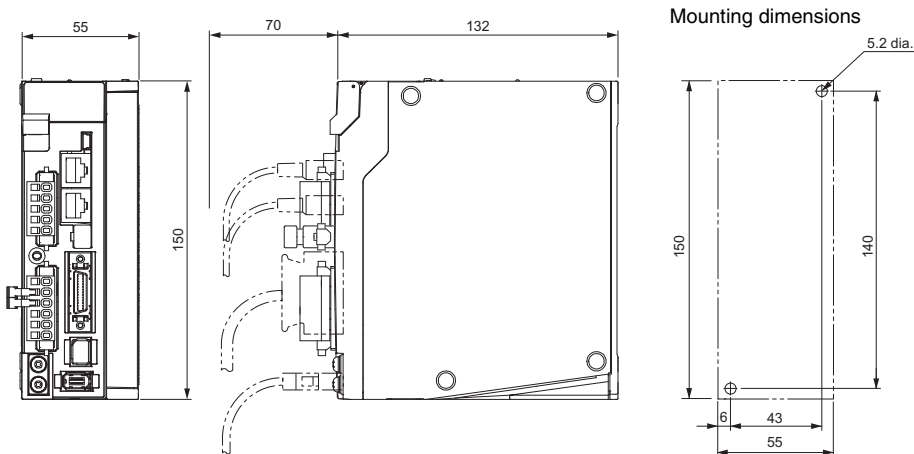

Single-phase 100 VAC R88D-KN04L-ECT-R (400W)

Single-phase/for Three-phase 200 VAC R88D-KN08H-ECT-R (750W)

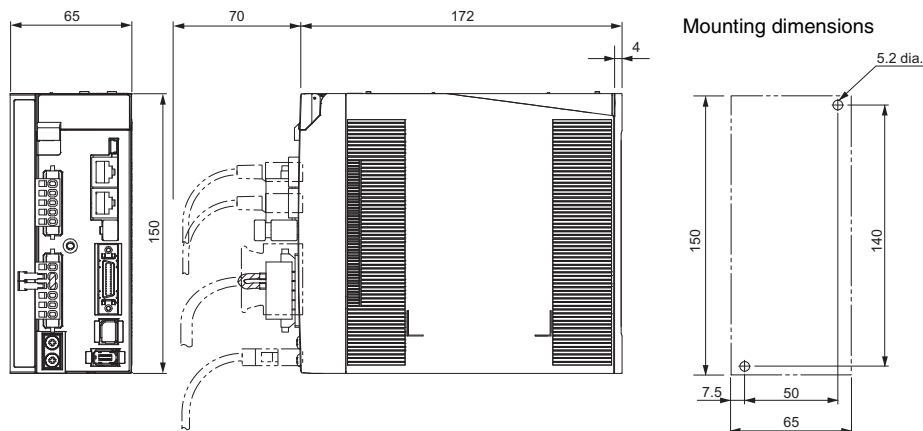

**Single-phase/Three-phase 200 VAC R88D-KN10H-ECT-R/-KN15H-ECT-R (900W to 1.5kW)**

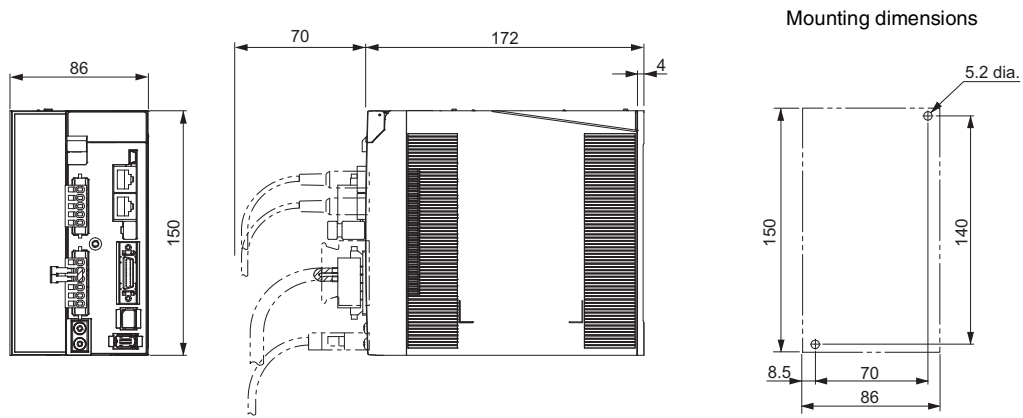

**Three-phase 400 VAC R88D-KN06F-ECT-R/-KN10F-ECT-R (600W to 1.0kW)  
Three-phase 400 VAC R88D-KN15F-ECT-R (1.5kW)**

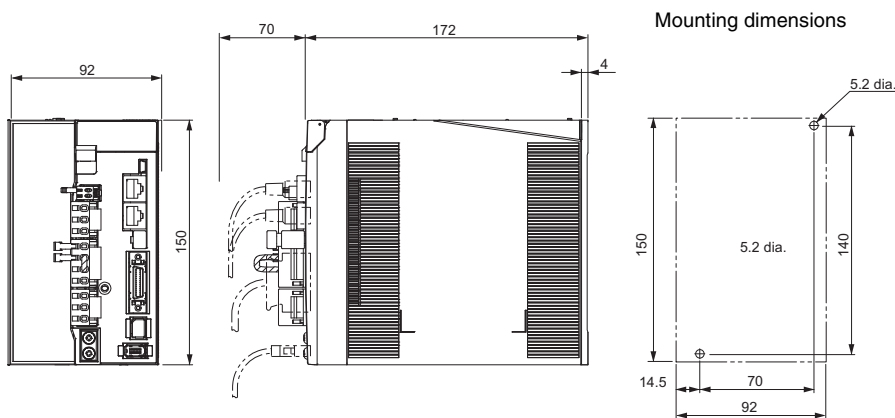

# OMNUC G5-series AC Servomotors

# R88M-K INC ABS/INC

## Contents

- Ordering Information
- Specifications
  - General Specifications
  - Characteristics/Torque and Rotation Speed Characteristics
  - <Cylinder type>
    - 3,000 r/min servomotors (100V, 200V, 400V)
    - 2,000 r/min servomotors (200V, 400V)
    - 1,000 r/min servomotors (200V/400V)
  - Encoder Specifications
- Dimensions

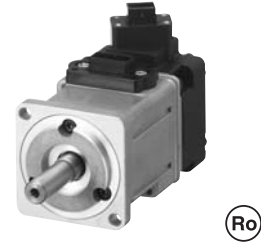

## Ordering Information

Refer to the Ordering Information.

## Specifications

### General Specifications

Item	3,000-r/min Servomotors		1,000-r/min Servomotors 2,000-r/min Servomotors
	50 to 750 W	1 to 1.5 kW	900 W to 1.5 kW
Ambient operating temperature and operating humidity	0 to 40°C, 20% to 85%RH (with no condensation)		
Storage ambient temperature and humidity	-20 to 65°C, 20% to 85%RH (with no condensation) Maximum temperature of 80°C (72 hours at normal humidity)		
Operating and storage atmosphere	No corrosive gases		
Vibration resistance *1	Acceleration of 49 m/s <sup>2</sup> 24.5 m/s <sup>2</sup> max. in X, Y, and Z directions when the motor is stopped		
Impact resistance	Acceleration of 98 m/s <sup>2</sup> max. 3 times each in X, Y, and Z directions		
Insulation resistance	Between power terminal and FG terminal: 20 MΩ min. (at 500 VDC)		
Dielectric strength	1,500 VAC between power terminal and FG terminal for 1 min (voltage 100 V, 200 V) 1,800 VAC between power terminal and FG terminal for 1 min (voltage 400 V) 1,000 VAC between brake terminal and FG terminal for 1 min		
Protective structure	IP67 (except for through-shaft parts and motor and encoder connector pins)		
International standard	EC Directives	EMC Directive	EN 55011 class A group 1 EN 61000-6-2, IEC 61800-3 and IEC 61326-3-1
		Low Voltage Directive	EN 60034-1/-5
	UL standards		UL1004-1
	CSA standards		CSA22.2 No. 100

\*1. The amplitude may be increased by machine resonance. As a guideline, do not exceed 80% of the specified value.

**Note:** 1. Do not use the cable when it is laying in oil or water.

2. Do not expose the cable outlet or connections to stress due to bending or the weight of the cable itself.

## Characteristics/Torque and Rotation Speed Characteristics

### Characteristics

<Cylinder type>

3,000 r/min Servomotors (100 VAC Input Power)

Model (R88M-)		100 VAC				
		K05030H	K10030L	K20030L	K40030L	
Item	Unit	K05030T	K10030S	K20030S	K40030S	
Rated output *1	W	50	100	200	400	
Rated torque *1	N • m	0.16	0.32	0.64	1.3	
Rated rotation speed	r/min	3,000				
Maximum rotation speed	r/min	6,000				
Momentary maximum torque *1	N • m	0.48	0.95	1.91	3.8	
Rated current *1	A (rms)	1.1	1.6	2.5	4.6	
Momentary maximum current *1	A (rms)	4.7	6.9	10.6	19.5	
Rotor inertia	Without brake	kg • m <sup>2</sup>	0.025×10 <sup>-4</sup>	0.051×10 <sup>-4</sup>	0.14×10 <sup>-4</sup>	0.26×10 <sup>-4</sup>
	With brake	kg • m <sup>2</sup>	0.027×10 <sup>-4</sup>	0.054×10 <sup>-4</sup>	0.16×10 <sup>-4</sup>	0.28×10 <sup>-4</sup>
Applicable load inertia	—	30 times the rotor inertia max. *2				
Torque constant *1	N • m/A	0.11±10%	0.14±10%	0.20±10%	0.21±10%	
Power rate *1	Without brake	kW/s	10.1	19.8	28.9	62.3
	With brake	kW/s	9.4	18.7	25.3	57.8
Mechanical time constant	Without brake	ms	1.43	1.03	0.61	0.48
	With brake	ms	1.54	1.09	0.70	0.52
Electrical time constant	ms	0.82	0.91	3.0	3.4	
Allowable radial load *3	N	68	68	245	245	
Allowable thrust load *3	N	58	58	98	98	
Weight	Without brake	kg	Approx. 0.31	Approx. 0.45	Approx. 0.78	Approx. 1.2
	With brake	kg	Approx. 0.51	Approx. 0.65	Approx. 1.2	Approx. 1.6
Radiator plate dimensions (material)		100 × 80 × t10 (Al)		130 × 120 × t12 (Al)		
Applicable drives (R88D-)		KTA5L/KNA5L-ML2/ KNA5L-ECT-R	KT01L/KNA01L-ML2/ KN01L-ECT-R	KT02L/KN02L-ML2/ KN02L-ECT-R	KT04L/KN04L-ML2/ KN04L-ECT-R	
Brake specifications	Brake inertia	kg • m <sup>2</sup>	2×10 <sup>-7</sup>	2×10 <sup>-7</sup>	1.8×10 <sup>-6</sup>	1.8×10 <sup>-6</sup>
	Excitation voltage *4	V	24 VDC ± 10%			
	Power consumption (at 20°C)	W	7	7	9	9
	Current consumption (at 20°C)	A	0.3	0.3	0.36	0.36
	Static friction torque	N • m	0.29 min.	0.29 min.	1.27 min.	1.27 min.
	Attraction time *5	ms	35 max.	35 max.	50 max.	50 max.
	Release time *5	ms	20 max.	20 max.	15 max.	20 max.
	Backlash	—	1° (reference value)			
	Allowable work per braking	J	39.2	39.2	137	137
	Allowable total work	J	4.9×10 <sup>3</sup>	4.9×10 <sup>3</sup>	44.1×10 <sup>3</sup>	44.1×10 <sup>3</sup>
	Allowable angular acceleration	rad/s <sup>2</sup>	30,000 max. (Speed of 2,800 r/min or more must not be changed in less than 10 ms.)			
	Brake limit	—	10 million times min.			
Insulation class	—	Type B				

\*1. These are the values when the motor is combined with a drive at normal temperature (20°C, 65%). The momentary maximum torque indicates the standard value.

\*2. Applicable load inertia.

- The operable load inertia ratio (load inertia/rotor inertia) depends on the mechanical configuration and its rigidity. For a machine with high rigidity, operation is possible even with high load inertia. Select an appropriate motor and confirm that operation is possible.
- If the dynamic brake is activated frequently with high load inertia, the Dynamic Brake Resistor may burn. Do not repeatedly turn the servo ON/OFF while the dynamic brake is enabled.

\*3. The allowable radial and thrust loads are the values determined for a limit of 20,000 hours at normal operating temperatures. The allowable radial loads are applied as shown in the following diagram.

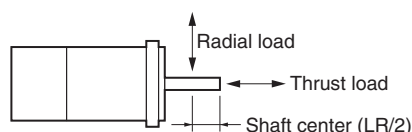

\*4. This is a non-excitation brake. (It is released when excitation voltage is applied.)

\*5. The operation time is the value (reference value) measured with a surge suppressor (CR50500 by Okaya Electric Industries Co., Ltd.).

## Torque and Rotation Speed Characteristics 3,000 r/min Servomotors (100 VAC Input Power)

The following graphs show the characteristics with a 3-m standard cable and a 100 VAC input.

### • R88M-K05030H/T (50W)

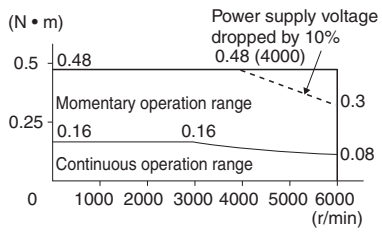

### • R88M-K10030L/S (100W)

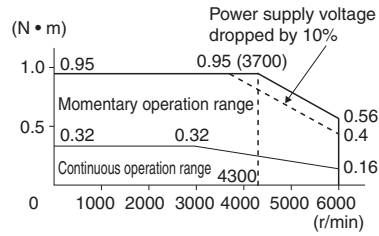

### • R88M-K20030L/S (200W)

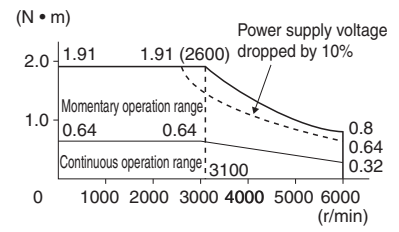

### • R88M-K40030L/S (400W)

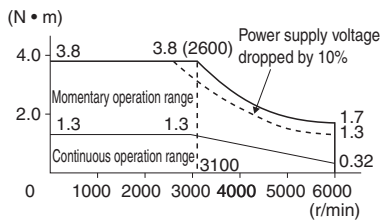

# AC Servomotor/Drive OMNUC G5-series

## Characteristics

### 3,000 r/min Servomotors (200 VAC Input Power)

Model (R88M-)			200 VAC						
			K05030H	K10030H	K20030H	K40030H	K75030H	K1K030H	K1K530H
Item	Unit	K05030T	K10030T	K20030T	K40030T	K75030T	K1K030T	K1K530T	
Rated output *1	W	50	100	200	400	750	1000	1500	
Rated torque *1	N • m	0.16	0.32	0.64	1.3	2.4	3.18	4.77	
Rated rotation speed	r/min	3,000				3,000			
Momentary maximum rotation speed	r/min	6,000				6,000	5,000		
Momentary maximum torque *1	N • m	0.48	0.95	1.91	3.8	7.1	9.55	14.3	
Rated current *1	A (rms)	1.1	1.1	1.5	2.4	4.1	6.6	8.2	
Momentary maximum current *1	A (rms)	4.7	4.7	6.5	10.2	17.4	28	35	
Rotor inertia	Without brake	kg • m <sup>2</sup>	0.025×10 <sup>-4</sup>	0.051×10 <sup>-4</sup>	0.14×10 <sup>-4</sup>	0.26×10 <sup>-4</sup>	0.87×10 <sup>-4</sup>	2.03×10 <sup>-4</sup>	2.84×10 <sup>-4</sup>
	With brake	kg • m <sup>2</sup>	0.027×10 <sup>-4</sup>	0.054 ×10 <sup>-4</sup>	0.16×10 <sup>-4</sup>	0.28×10 <sup>-4</sup>	0.97×10 <sup>-4</sup>	2.35×10 <sup>-4</sup>	3.17×10 <sup>-4</sup>
Applicable load inertia	—	30 times the rotor inertia max.*2				20 times the rotor inertia max.	15 times the rotor inertia max.*2		
Torque constant *1	N • m/A	0.11±10%	0.21±10%	0.32±10%	0.40±10%	0.45±10%	0.37	0.45	
Power rate *1	Without brake	kW/s	10.1	19.8	28.9	62.3	65.4	49.8	80.1
	With brake	kW/s	9.4	18.7	25.3	57.8	58.7	43.0	71.8
Mechanical time constant	Without brake	ms	1.43	1.07	0.58	0.43	0.37	0.61	0.49
	With brake	ms	1.54	1.13	0.66	0.46	0.42	0.71	0.55
Electrical time constant	ms	0.82	0.90	3.2	3.4	5.3	5.8	6.3	
Allowable radial load *3	N	68	68	245	245	490	490	490	
Allowable thrust load *3	N	58	58	98	98	196	196	196	
Weight	Without brake	kg	Approx. 0.31	Approx. 0.46	Approx. 0.79	Approx. 1.2	Approx. 2.3	Approx. 3.5	Approx. 4.4
	With brake	kg	Approx. 0.51	Approx. 0.66	Approx. 1.2	Approx. 1.6	Approx. 3.1	Approx. 4.5	Approx. 5.4
Radiator plate dimensions (material)		100 × 80 × t10 (Al)		130 × 120 × t12 (Al)		170 × 160 × t12 (Al)	320 × 300 × t20 (Al)		
Applicable drives (R88D-)		KT01H/ KN01H-ML2/ KN01H-ECT-R	KT01H/ KN01H-ML2/ KN01H-ECT-R	KT02H/ KN02H-ML2/ KN02H-ECT-R	KT04H/ KN04H-ML2/ KN04H-ECT-R	KT08H/ KN08H-ML2/ KN08H-ECT-R	KT15H/ KN15H-ML2/ KN15H-ECT-R	KT15H/ KN15H-ML2/ KN15H-ECT-R	
Brake specifications	Brake inertia	kg • m <sup>2</sup>	2×10 <sup>-7</sup>	2×10 <sup>-7</sup>	1.8×10 <sup>-6</sup>	1.8×10 <sup>-6</sup>	0.33×10 <sup>-4</sup>	0.33×10 <sup>-4</sup>	0.33×10 <sup>-4</sup>
	Excitation voltage *4	V	24 VDC ± 10%				24 VDC ± 10%		
	Power consumption (at 20°C)	W	7	7	9	9	17	19	19
	Current consumption (at 20°C)	A	0.3	0.3	0.36	0.36	0.70±10%	0.81±10%	0.81±10%
	Static friction torque	N • m	0.29 min.	0.29 min.	1.27 min.	1.27 min.	2.5 min.	7.8 min.	7.8 min.
	Attraction time *5	ms	35 max.	35 max.	50 max.	50 max.	50 max.	50 max.	50 max.
	Release time *5	ms	20 max.	20 max.	15 max.	15 max.	15 max.*6	15 max.*6	15 max.*6
	Backlash		1° (reference value)				±1° (reference value)		
	Allowable work per braking	J	39.2	39.2	137	137	392	392	392
	Allowable total work	J	4.9×10 <sup>3</sup>	4.9×10 <sup>3</sup>	44.1×10 <sup>3</sup>	44.1×10 <sup>3</sup>	4.9×10 <sup>5</sup>	4.9×10 <sup>5</sup>	4.9×10 <sup>5</sup>
	Allowable angular acceleration	rad/s <sup>2</sup>	30,000 max. (Speed of 2,800 r/min or more must not be changed in less than 10 ms.)				10,000		
	Brake limit	—	10 million times min.						
Insulation class	—	Type B					Type F		

\*1. These are the values when the motor is combined with a drive at normal temperature (20°C, 65%). The momentary maximum torque indicates the standard value.

\*2. Applicable load inertia.

- The operable load inertia ratio (load inertia/rotor inertia) depends on the mechanical configuration and its rigidity. For a machine with high rigidity, operation is possible even with high load inertia. Select an appropriate motor and confirm that operation is possible.
- If the dynamic brake is activated frequently with high load inertia, the Dynamic Brake Resistor may burn. Do not repeatedly turn the servo ON/OFF while the dynamic brake is enabled.

\*3. The allowable radial and thrust loads are the values determined for a limit of 20,000 hours at normal operating temperatures. The allowable radial loads are applied as shown in the following diagram.

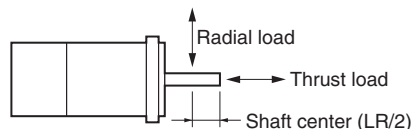

\*4. This is a non-excitation brake. (It is released when excitation voltage is applied.)

\*5. The operation time is the value (reference value) measured with a surge suppressor (CR50500 by Okaya Electric Industries Co., Ltd.).

\*6. Direct current switching with a varistor (Z15D151 by Ishizuka Electronics Co.).

\*7. Direct current switching with a varistor (TNR9G820K by Nippon Chemi-Con Corporation).

## Torque and Rotation Speed Characteristics 3,000 r/min Servomotors (200 VAC Input Power)

The following graphs show the characteristics with a 3-m standard cable and a 200 VAC input.

- R88M-K05030H/T (50W)

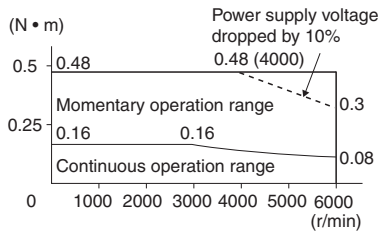

- R88M-K10030H/T (100W)

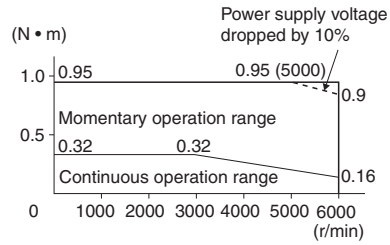

- R88M-K20030H/T (200W)

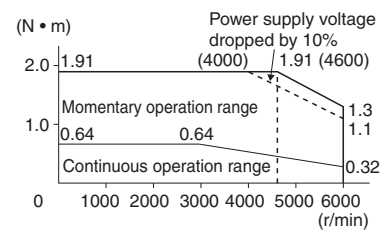

- R88M-K40030H/T (400W)

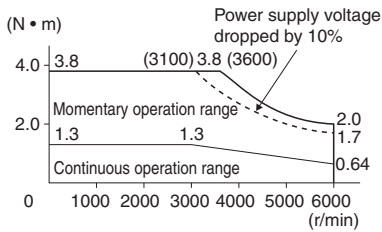

- R88M-K75030H/T (750W)

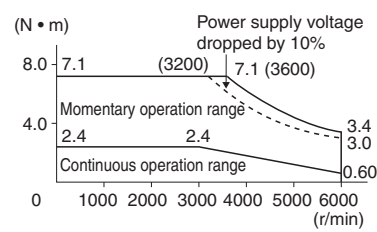

- R88M-K1K030H/T (1kW)

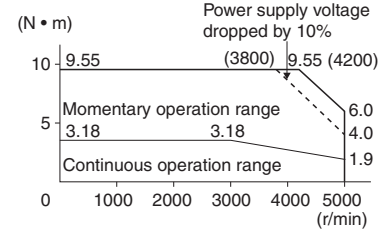

- R88M-K1K530H/T (1.5kW)

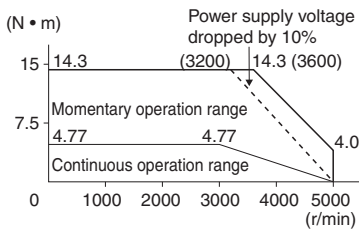



# AC Servomotor/Drive OMNUC G5-series

## Characteristics

### 3,000 r/min Servomotors (400 VAC Input Power)

Model (R88M-)		400 VAC			
		K75030F	K1K030F	K1K530F	
Item	Unit	K75030C	K1K030C	K1K530C	
Rated output *1	W	750	1000	1500	
Rated torque *1	N • m	2.39	3.18	4.77	
Rated rotation speed	r/min	3,000			
Momentary maximum rotation speed	r/min	5,000			
Momentary maximum torque *1	N • m	7.16	9.55	14.3	
Rated current *1	A (rms)	2.4	3.3	4.2	
Momentary maximum current *1	A (rms)	10	14	18	
Rotor inertia	Without brake	kg • m <sup>2</sup>	1.61×10 <sup>-4</sup>	2.03×10 <sup>-4</sup>	2.84×10 <sup>-4</sup>
	With brake	kg • m <sup>2</sup>	1.93×10 <sup>-4</sup>	2.35×10 <sup>-4</sup>	3.17×10 <sup>-4</sup>
Applicable load inertia	—	30 times the rotor inertia max. *2			
Torque constant *1	N • m/A	0.78	0.75	0.89	
Power rate *1	Without brake	kW/s	35.5	49.8	80.1
	With brake	kW/s	29.6	43	71.8
Mechanical time constant	Without brake	ms	0.67	0.60	0.49
	With brake	ms	0.8	0.70	0.55
Electrical time constant	ms	5.9	5.8	6.5	
Allowable radial load *3	N	490	490	490	
Allowable thrust load *3	N	196	196	196	
Weight	Without brake	kg	Approx. 3.1	Approx. 3.5	Approx. 4.4
	With brake	kg	Approx. 4.1	Approx. 4.5	Approx. 5.4
Radiator plate dimensions (material)		320 × 300 × t20 (Al)			
Applicable drives (R88D-)		KT10F/KN10F-ML2/ KN10F-ECT-R	KT15F/KN15F-ML2/ KN15F-ECT-R	KT15F/KN15F-ML2/ KN15F-ECT-R	
Brake specifications	Brake inertia	kg • m <sup>2</sup>	0.33×10 <sup>-4</sup>	0.33×10 <sup>-4</sup>	0.33×10 <sup>-4</sup>
	Excitation voltage *4	V	24 VDC ± 10%		
	Power consumption (at 20°C)	W	17	19	19
	Current consumption (at 20°C)	A	0.70±10%	0.81±10%	0.81±10%
	Static friction torque	N • m	2.5 min.	7.8 min.	7.8 min.
	Attraction time *5	ms	50 max.	50 max.	50 max.
	Release time *5	ms	15 max. *6	15 max. *6	15 max. *6
	Backlash		1° (reference value)		
	Allowable work per braking	J	392	392	392
	Allowable total work	J	4.9×10 <sup>5</sup>	4.9×10 <sup>5</sup>	4.9×10 <sup>5</sup>
	Allowable angular acceleration	rad/s <sup>2</sup>	10,000		
	Brake limit	—	10 million times min.		
Insulation class	—	Type F			

\*1. These are the values when the motor is combined with a drive at normal temperature (20°C, 65%). The momentary maximum torque indicates the standard value.

\*2. Applicable load inertia.

- The operable load inertia ratio (load inertia/rotor inertia) depends on the mechanical configuration and its rigidity. For a machine with high rigidity, operation is possible even with high load inertia. Select an appropriate motor and confirm that operation is possible.
- If the dynamic brake is activated frequently with high load inertia, the Dynamic Brake Resistor may burn. Do not repeatedly turn the servo ON/OFF while the dynamic brake is enabled.

\*3. The allowable radial and thrust loads are the values determined for a limit of 20,000 hours at normal operating temperatures. The allowable radial loads are applied as shown in the following diagram.

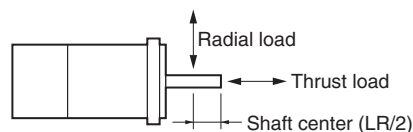

\*4. This is a non-excitation brake. (It is released when excitation voltage is applied.)

\*5. The operation time is the value (reference value) measured with a surge suppressor (CR50500 by Okaya Electric Industries Co., Ltd.).

\*6. Direct current switching with a varistor (Z15D151 by Ishizuka Electronics Co.).

\*7. Direct current switching with a varistor (TNR9G820K by Nippon Chemi-Con Corporation).

## Torque and Rotation Speed Characteristics 3,000 r/min Servomotors (400 VAC Input Power)

The following graphs show the characteristics with a 3-m standard cable and a 400 VAC input.

- R88M-K75030F/C (750W)

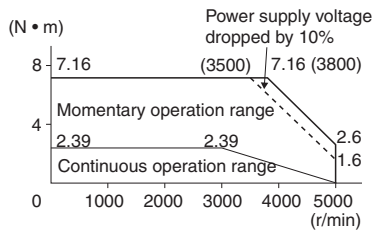

- R88M-K1K030F/C (1kW)

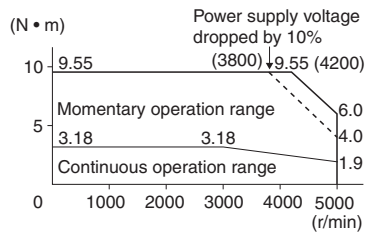

- R88M-K1K530F/C (1.5kW)

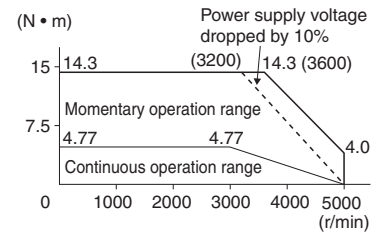

# AC Servomotor/Drive OMNUC G5-series

## Characteristics

### 2,000 r/min Servomotors (200 VAC Input Power)

Model (R88M-)			200 VAC	
			K1K020H	K1K520H
Item	Unit	K1K020T	K1K520T	
Rated output *1	W	1,000	1,500	
Rated torque *1	N • m	4.77	7.16	
Rated rotation speed	r/min	2,000		
Momentary maximum rotation speed	r/min	3,000		
Momentary maximum torque *1	N • m	14.3	21.5	
Rated current *1	A (rms)	5.7	9.4	
Momentary maximum current *1	A (rms)	24	40	
Rotor inertia	Without brake	kg • m <sup>2</sup>	4.60×10 <sup>-4</sup>	6.70×10 <sup>-4</sup>
	With brake	kg • m <sup>2</sup>	5.90×10 <sup>-4</sup>	7.99×10 <sup>-4</sup>
Applicable load inertia	—	10 times the rotor inertia max. *2		
Torque constant *1	N • m/A	0.63	0.58	
Power rate *1	Without brake	kW/s	49.5	76.5
	With brake	kW/s	38.6	64.2
Mechanical time constant	Without brake	ms	0.80	0.66
	With brake	ms	1.02	0.80
Electrical time constant	ms	9.4	10	
Allowable radial load *3	N	490	490	
Allowable thrust load *3	N	196	196	
Weight	Without brake	kg	Approx. 5.2	Approx. 6.7
	With brake	kg	Approx. 6.7	Approx. 8.2
Radiator plate dimensions (material)		275 × 260 × t15 (Al)		
Applicable drives (R88D-)		KT10H/KN10H-ML2/KN10H-ECT-R	KT15H/KN15H-ML2/KN15H-ECT-R	
Brake specifications	Brake inertia	kg • m <sup>2</sup>	1.35×10 <sup>-4</sup>	1.35×10 <sup>-4</sup>
	Excitation voltage *4	V	24 VDC ± 10%	
	Power consumption (at 20°C)	W	14	19
	Current consumption (at 20°C)	A	0.59±10%	0.79±10%
	Static friction torque	N • m	4.9 min.	13.7 min.
	Attraction time *5	ms	80 max.	100 max.
	Release time *5	ms	70 max. *6	50 max. *6
	Backlash	—	1° (reference value)	
	Allowable work per braking	J	588	1,176
	Allowable total work	J	7.8×10 <sup>5</sup>	1.5×10 <sup>6</sup>
	Allowable angular acceleration	rad/s <sup>2</sup>	10,000	
	Brake limit	—	10 million times min.	
	Insulation class	—	Type F	

\*1. These are the values when the motor is combined with a drive at normal temperature (20°C, 65%). The momentary maximum torque indicates the standard value.

\*2. Applicable load inertia.

- The operable load inertia ratio (load inertia/rotor inertia) depends on the mechanical configuration and its rigidity. For a machine with high rigidity, operation is possible even with high load inertia. Select an appropriate motor and confirm that operation is possible.
- If the dynamic brake is activated frequently with high load inertia, the Dynamic Brake Resistor may burn. Do not repeatedly turn the servo ON/OFF while the dynamic brake is enabled.

\*3. The allowable radial and thrust loads are the values determined for a limit of 20,000 hours at normal operating temperatures. The allowable radial loads are applied as shown in the following diagram.

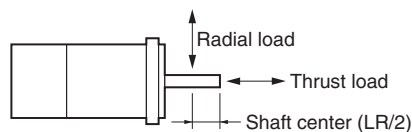

\*4. This is a non-excitation brake. (It is released when excitation voltage is applied.)

\*5. The operation time is the value (reference value) measured with a surge suppressor (CR50500 by Okaya Electric Industries Co., Ltd.).

\*6. Direct current switching with a varistor (Z15D151 by Ishizuka Electronics Co.).

\*7. Direct current switching with a varistor (TNR9G820K by Nippon Chemi-Con Corporation).

**Torque and Rotation Speed Characteristics**  
**2,000 r/min Servomotors (200 VAC Input Power)**

The following graphs show the characteristics with a 3-m standard cable and a 200 VAC input.

- R88M-K1K020H/T (1kW)

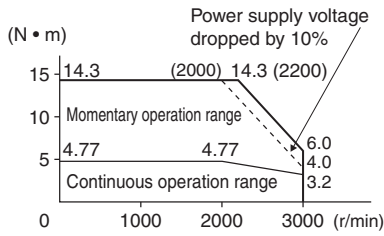

- R88M-K1K520H/T (1.5kW)

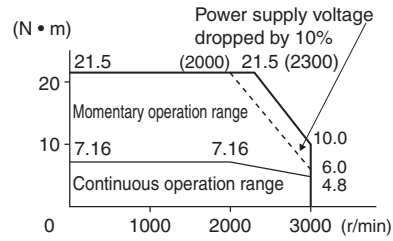

# AC Servomotor/Drive OMNUC G5-series

## Characteristics

### 2,000 r/min Servomotors (400 VAC Input Power)

Model (R88M-)		400 VAC				
		K40020F	K60020F	K1K020F	K1K520F	
Item	Unit	K40020C	K60020C	K1K020C	K1K520C	
Rated output *1	W	400	600	1,000	1,500	
Rated torque *1	N • m	1.91	2.86	4.77	7.16	
Rated rotation speed	r/min	2,000				
Momentary maximum rotation speed	r/min	3,000				
Momentary maximum torque *1	N • m	5.73	8.59	14.3	21.5	
Rated current *1	A (rms)	1.2	1.5	2.8	4.7	
Momentary maximum current *1	A (rms)	4.9	6.5	12	20	
Rotor inertia	Without brake	kg • m <sup>2</sup>	1.61×10 <sup>-4</sup>	2.03×10 <sup>-4</sup>	4.60×10 <sup>-4</sup>	6.70×10 <sup>-4</sup>
	With brake	kg • m <sup>2</sup>	1.90×10 <sup>-4</sup>	2.35×10 <sup>-4</sup>	5.90×10 <sup>-4</sup>	7.99×10 <sup>-4</sup>
Applicable load inertia	—	10 times the rotor inertia max. *2				
Torque constant *1	N • m/A	1.27	1.38	1.27	1.16	
Power rate *1	Without brake	kW/s	22.7	40.3	49.5	76.5
	With brake	kW/s	19.2	34.8	38.6	64.2
Mechanical time constant	Without brake	ms	0.70	0.62	0.79	0.66
	With brake	ms	0.83	0.72	1.01	0.79
Electrical time constant	ms	5.7	5.9	10	10	
Allowable radial load *3	N	490	490	490	490	
Allowable thrust load *3	N	196	196	196	196	
Weight	Without brake	kg	Approx. 3.1	Approx. 3.5	Approx. 5.2	Approx. 6.7
	With brake	kg	Approx. 4.1	Approx. 4.5	Approx. 6.7	Approx. 8.2
Radiator plate dimensions (material)		320 × 300 × t20 (Al)		275 × 260 × t15 (Al)		
Applicable drives (R88D-)		KT06F/KN06F-ML2/ KN06F-ECT-R	KT06F/KN06F-ML2/ KN06F-ECT-R	KT10F/KN10F-ML2/ KN10F-ECT-R	KT15F/KN15F-ML2/ KN15F-ECT-R	
Brake specifications	Brake inertia	kg • m <sup>2</sup>	1.35×10 <sup>-4</sup>	1.35×10 <sup>-4</sup>	1.35×10 <sup>-4</sup>	1.35×10 <sup>-4</sup>
	Excitation voltage *4	V	24 VDC ± 10%			
	Power consumption (at 20°C)	W	17	17	14	19
	Current consumption (at 20°C)	A	0.70±10%	0.70±10%	0.59±10%	0.79±10%
	Static friction torque	N • m	2.5 min.	2.5 min.	4.9 min.	13.7 min.
	Attraction time *5	ms	50 max.	50 max.	80 max.	100 max.
	Release time *5	ms	15 max. *7	15 max. *7	70 max. *6	50 max. *6
	Backlash	—	1° (reference value)			
	Allowable work per braking	J	392	392	588	1176
	Allowable total work	J	4.9×10 <sup>5</sup>	4.9×10 <sup>5</sup>	7.8×10 <sup>5</sup>	1.5×10 <sup>6</sup>
	Allowable angular acceleration	rad/s <sup>2</sup>	10,000			
	Brake limit	—	10 million times min.			
Insulation class	—	Type F				

\*1. These are the values when the motor is combined with a drive at normal temperature (20°C, 65%). The momentary maximum torque indicates the standard value.

\*2. Applicable load inertia.

- The operable load inertia ratio (load inertia/rotor inertia) depends on the mechanical configuration and its rigidity. For a machine with high rigidity, operation is possible even with high load inertia. Select an appropriate motor and confirm that operation is possible.
- If the dynamic brake is activated frequently with high load inertia, the Dynamic Brake Resistor may burn. Do not repeatedly turn the servo ON/OFF while the dynamic brake is enabled.

\*3. The allowable radial and thrust loads are the values determined for a limit of 20,000 hours at normal operating temperatures. The allowable radial loads are applied as shown in the following diagram.

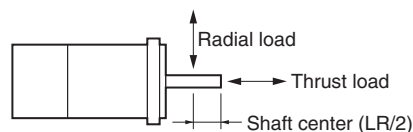

\*4. This is a non-excitation brake. (It is released when excitation voltage is applied.)

\*5. The operation time is the value (reference value) measured with a surge suppressor (CR50500 by Okaya Electric Industries Co., Ltd.).

\*6. Direct current switching with a varistor (Z15D151 by Ishizuka Electronics Co.).

\*7. Direct current switching with a varistor (TNR9G820K by Nippon Chemi-Con Corporation).

## Torque and Rotation Speed Characteristics 2,000 r/min Servomotors (400 VAC Input Power)

The following graphs show the characteristics with a 3-m standard cable and a 400 VAC input.

- R88M-K40020F/C (400W)

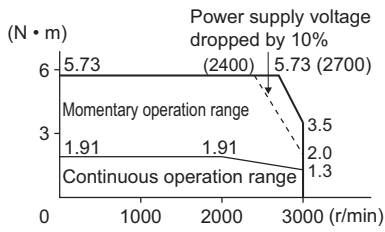

- R88M-K60020F/C (600W)

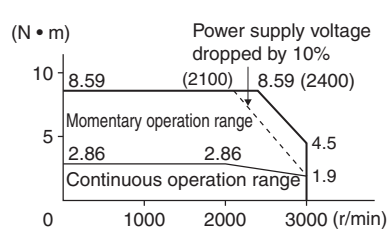

- R88M-K1K020F/C (1kW)

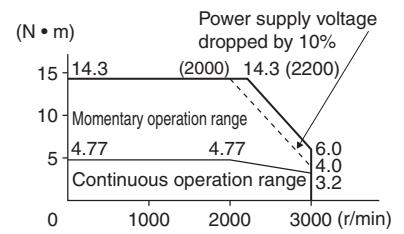

- R88M-K1K520F/C (1.5kW)

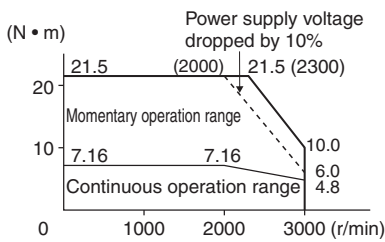

# AC Servomotor/Drive OMNUC G5-series

## Characteristics

### 1,000 r/min Servomotors (200/400 VAC Input Power)

Model (R88M-)		200 VAC	400 VAC
Item		Unit	
		K90010H	K90010F
		K90010T	K90010C
Rated output *1	W	900	900
Rated torque *1	N • m	8.59	8.59
Rated rotation speed	r/min	1,000	
Momentary maximum rotation speed	r/min	2,000	
Momentary maximum torque *1	N • m	19.3	19.3
Rated current *1	A (rms)	7.6	3.8
Momentary maximum current *1	A (rms)	24	12
Rotor inertia	Without brake	kg • m <sup>2</sup>	6.70×10 <sup>-4</sup>
	With brake	kg • m <sup>2</sup>	7.99×10 <sup>-4</sup>
Applicable load inertia	—	10 times the rotor inertia max. *2	
Torque constant *1	N • m/A	0.86	1.72
Power rate *1	Without brake	kW/s	110
	With brake	kW/s	92.4
Mechanical time constant	Without brake	ms	0.66
	With brake	ms	0.79
Electrical time constant	ms	11	11
Allowable radial load *3	N	686	686
Allowable thrust load *3	N	196	196
Weight	Without brake	kg	Approx. 6.7
	With brake	kg	Approx. 8.2
Radiator plate dimensions (material)		270 × 260 × t15 (Al)	
Applicable drives (R88D-)		KT15H/KN15H-ML2/ KN15H-ECT-R	KT15F/KN15F-ML2/ KN15F-ECT-R
Brake specifications	Brake inertia	kg • m <sup>2</sup>	1.35×10 <sup>-4</sup>
	Excitation voltage *4	V	24 VDC ± 10%
	Power consumption (at 20°C)	W	19
	Current consumption (at 20°C)	A	0.79±10%
	Static friction torque	N • m	13.7 min.
	Attraction time *5	ms	100 max.
	Release time *5	ms	50 max. *6
	Backlash		1° (reference value)
	Allowable work per braking	J	1176
	Allowable total work	J	1.5×10 <sup>6</sup>
	Allowable angular acceleration	rad/s <sup>2</sup>	10,000
	Brake limit	—	10 million times min.
	Insulation class	—	Type F

\*1. These are the values when the motor is combined with a drive at normal temperature (20°C, 65%). The momentary maximum torque indicates the standard value.

\*2. Applicable load inertia.

- The operable load inertia ratio (load inertia/rotor inertia) depends on the mechanical configuration and its rigidity. For a machine with high rigidity, operation is possible even with high load inertia. Select an appropriate motor and confirm that operation is possible.
- If the dynamic brake is activated frequently with high load inertia, the Dynamic Brake Resistor may burn. Do not repeatedly turn the servo ON/OFF while the dynamic brake is enabled.

\*3. The allowable radial and thrust loads are the values determined for a limit of 20,000 hours at normal operating temperatures. The allowable radial loads are applied as shown in the following diagram.

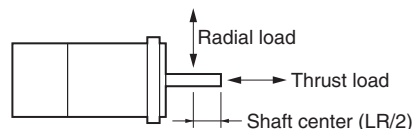

\*4. This is a non-excitation brake. (It is released when excitation voltage is applied.)

\*5. The operation time is the value (reference value) measured with a surge suppressor (CR50500 by Okaya Electric Industries Co., Ltd.).

\*6. Direct current switching with a varistor (Z15D151 by Ishizuka Electronics Co.).

\*7. Direct current switching with a varistor (TNR9G820K by Nippon Chemi-Con Corporation).

## Torque and Rotation Speed Characteristics 1,000 r/min Servomotors (200/400 VAC Input Power)

The following graphs show the characteristics with a 3-m standard cable and a 200 VAC input.

- R88M-K90010H/T/F/C (900W)

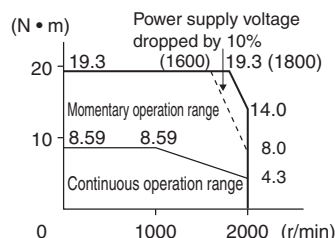

## Encoder Specifications

### Incremental Encoders

Item	Specifications
<b>Encoder system</b>	Optical encoder
	20 bits
<b>Number of output pulses</b>	Phases A and B: 262,144 pulses/rotation Phase Z: 1 pulse/rotation
<b>Power supply voltage</b>	5 VDC $\pm$ 5%
<b>Power supply current</b>	180 mA (max.)
<b>Output signal</b>	+S, -S
<b>Output interface</b>	RS485 compliant

### Absolute Encoders

Item	Specifications
<b>Encoder system</b>	Optical encoder
	17 bits
<b>Number of output pulses</b>	Phases A and B: 32,768 pulses/rotation Phase Z: 1 pulse/rotation
<b>Maximum rotations</b>	-32,768 to +32,767 rotations or 0 to 65,535 rotations
<b>Power supply voltage</b>	5 VDC $\pm$ 5%
<b>Power supply current</b>	110 mA (max.)
<b>Applicable battery voltage</b>	3.6 VDC
<b>Current consumption of battery</b>	265 $\mu$ A (for a maximum of 5 s right after power interruption) 100 $\mu$ A (for operation during power interruption) 3.6 $\mu$ A (when power is supplied to the drive)
<b>Output signal</b>	+S, -S
<b>Output interface</b>	RS485 compliant



# AC Servomotor/Drive OMNUC G5-series

## Dimensions

<Cylinder type>

### 3,000 r/min Servomotors (100/200 VAC)

50W/100W

• Without brake

- R88M-K05030H (-S2)/-K10030L (-S2) **INC**
- R88M-K05030T (-S2)/-K10030S (-S2) **ABS**

Speed	Voltage	Motor capacity	Brake
3000r/min	100/200V	50/100W	Without brake
			With brake

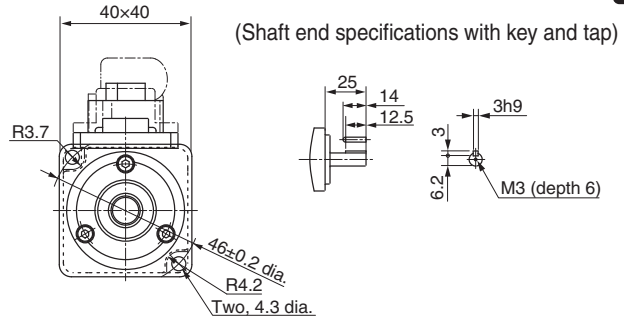
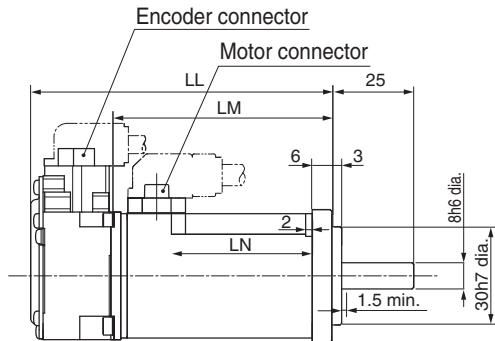

CAD data

Model	Dimensions (mm)		
	LL	LM	LN
R88M-K05030□	72	48	23
R88M-K10030□	92	68	43

**Note:** The standard models have a straight shaft. A model with a key and tap is indicated by adding “S2” to the end of the model number.

• With brake

- R88M-K05030H-B (S2)/-K10030L-B (S2) **INC**
- R88M-K05030T-B (S2)/-K10030S-B (S2) **ABS**

Speed	Voltage	Motor capacity	Brake
3000r/min	100/200V	50/100W	Without brake
			With brake

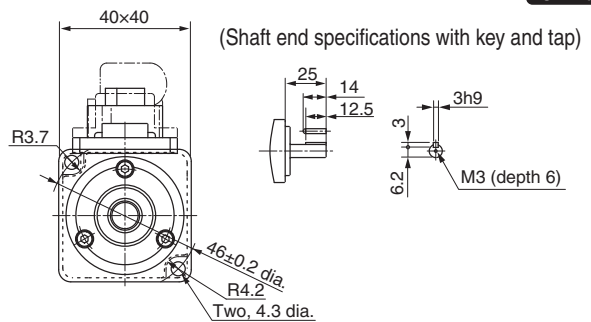
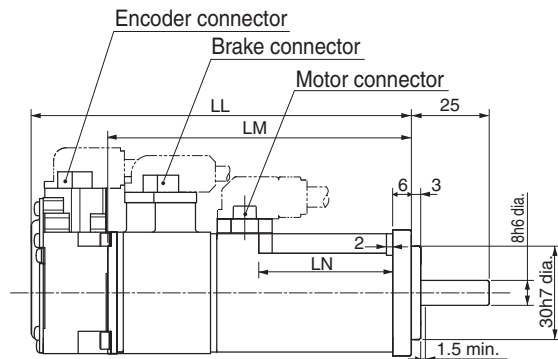

CAD data

Model	Dimensions (mm)		
	LL	LM	LN
R88M-K05030□-B□	102	78	23
R88M-K10030□-B□	122	98	43

**Note:** The standard models have a straight shaft. A model with a key and tap is indicated by adding “S2” to the end of the model number.

## 200W/400W

### • Without brake

- R88M-K20030□ (-S2)/-K40030□ (-S2) **INC**
- R88M-K20030□ (-S2)/-K40030□ (-S2) **ABS**

Speed	Voltage	Motor capacity	Brake
3000r/min	100/200V	200/400W	Without brake
			With brake

**CAD data**

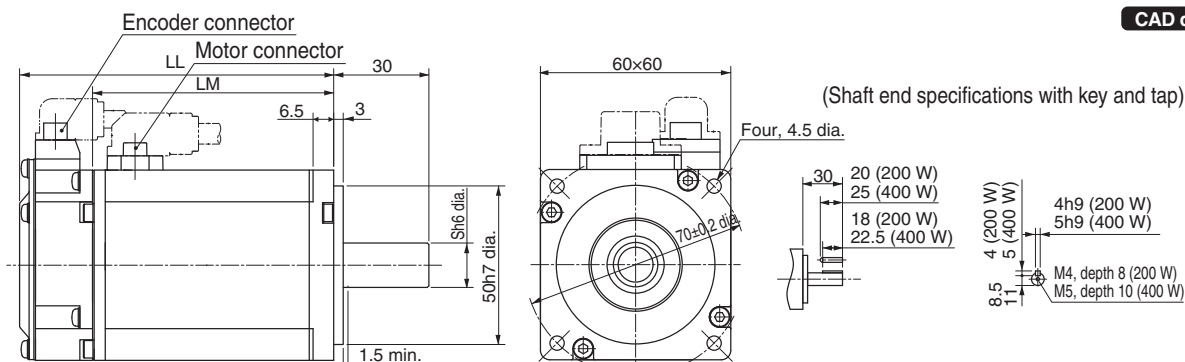

Model	Dimensions (mm)		
	LL	LM	LN
R88M-K20030□	79.5	56.5	11
R88M-K40030□	99	76	14

**Note:** The standard models have a straight shaft. A model with a key and tap is indicated by adding "S2" to the end of the model number.

### • With brake

- R88M-K20030□-B (S2)/-K40030□-B (S2) **INC**
- R88M-K20030□-B (S2)/-K40030□-B (S2) **ABS**

Speed	Voltage	Motor capacity	Brake
3000r/min	100/200V	200/400W	Without brake
			With brake

**CAD data**

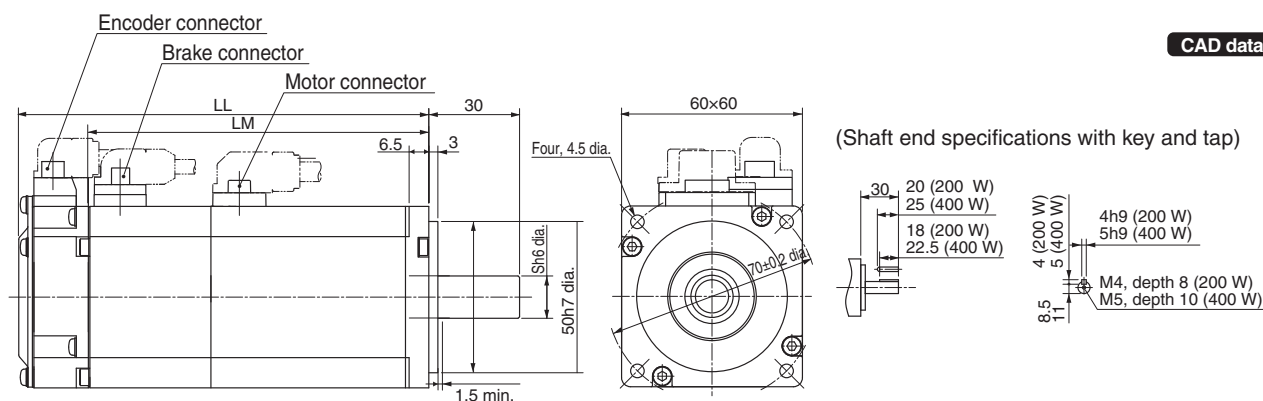

Model	Dimensions (mm)		
	LL	LM	S
R88M-K20030□-B□	116	93	11
R88M-K40030□-B□	135.5	112.5	14

**Note:** The standard models have a straight shaft. A model with a key and tap is indicated by adding "S2" to the end of the model number.

# AC Servomotor/Drive OMNUC G5-series

## 750W

### • Without brake

- R88M-K75030H (-S2) **INC**
- R88M-K75030T (-S2) **ABS**

Speed	Voltage	Motor capacity	Brake
3000r/min	100/200V	750W	Without brake
			With brake

**CAD data**

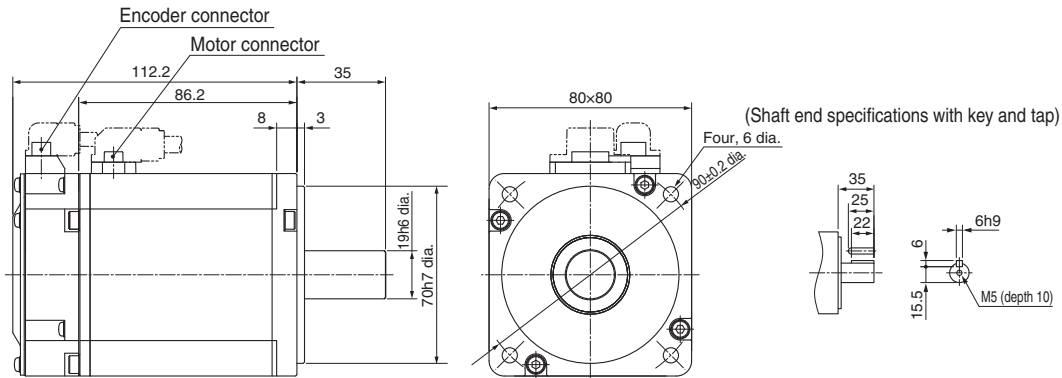

**Note:** The standard models have a straight shaft. A model with a key and tap is indicated by adding “S2” to the end of the model number.

### • With brake

- R88M-K75030H-B (S2) **INC**
- R88M-K75030T-B (S2) **ABS**

Speed	Voltage	Motor capacity	Brake
3000r/min	100/200V	750W	Without brake
			With brake

**CAD data**

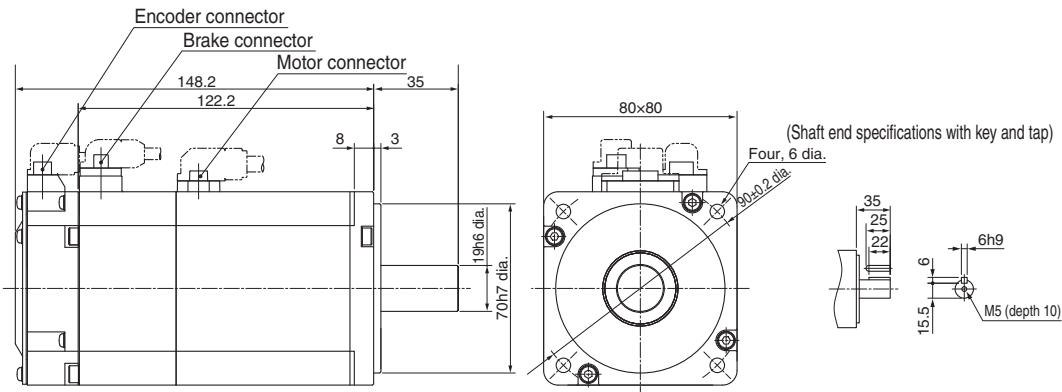

**Note:** The standard models have a straight shaft. A model with a key and tap is indicated by adding “S2” to the end of the model number.

## 1kW/1.5kW

### • Without brake

- R88M-K1K030H (-S2)/-K1K530H (-S2) **INC**
- R88M-K1K030T (-S2)/-K1K530T (-S2) **ABS**

### • With brake

- R88M-K1K030H-B (S2)/-K1K530H-B (S2) **INC**
- R88M-K1K030T-B (S2)/-K1K530T-B (S2) **ABS**

Speed	Voltage	Motor capacity	Brake
3000r/min	100/200V	1/1.5kW	Without brake
			With brake

**CAD data**

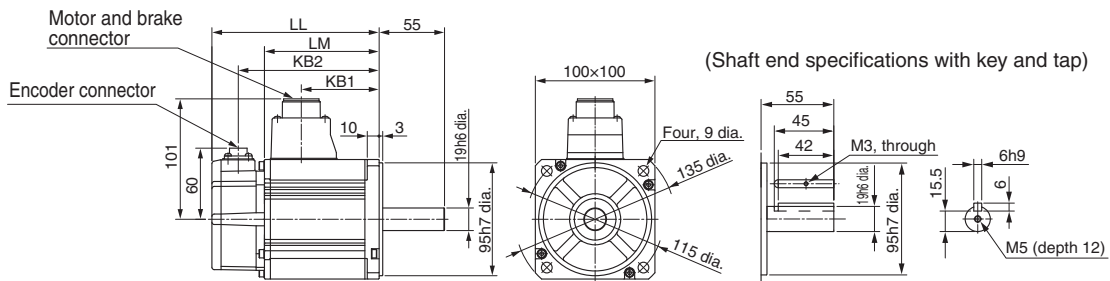

Model	Dimensions (mm)			
	LL	LM	KB1	KB2
R88M-K1K030□	141	97	66	119
R88M-K1K530□	159.5	115.5	84.5	137.5
R88M-K1K030□-B□	168	124	66	146
R88M-K1K530□-B□	186.5	142.5	84.5	164.5

**Note:** The standard models have a straight shaft. A model with a key and tap is indicated by adding “S2” to the end of the model number.

### 3,000 r/min Servomotors (400 VAC)

750W/1kW/1.5kW

• Without brake

- R88M-K75030F (-S2)/-K1K030F (-S2)/-K1K530F (-S2) **INC**
- R88M-K75030C (-S2)/-K1K030C (-S2)/-K1K530C (-S2) **ABS**

• With brake

- R88M-K75030F-B (S2)/-K1K030F-B (S2)/-K1K530F-B (S2)/-K2K030F-B (S2) **INC**
- R88M-K75030C-B (S2)/-K1K030C-B (S2)/-K1K530C-B (S2)/-K2K030C-B (S2) **ABS**

Speed	Voltage	Motor capacity	Brake
3000r/min	400V	750W/ 1/1.5kW	Without brake With brake

**CAD data**

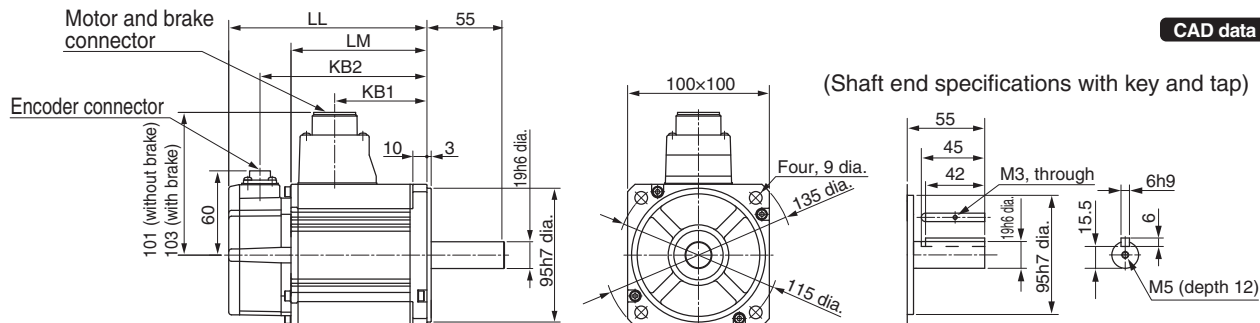

Model	Dimensions (mm)			
	LL	LM	KB1	KB2
R88M-K75030□	131.5	87.5	56.5	109.5
R88M-K1K030□	141	97	66	119
R88M-K1K530□	159.5	115.5	84.5	137.5
R88M-K75030□-B□	158.5	114.5	53.5	136.5
R88M-K1K030□-B□	168	124	63	146
R88M-K1K530□-B□	186.5	142.5	81.5	164.5

**Note:** The standard models have a straight shaft. A model with a key and tap is indicated by adding "S2" to the end of the model number.

### 2,000 r/min Servomotors (200 VAC)

1kW/1.5kW

• Without brake

- R88M-K1K020H (-S2)/-K1K520H (-S2) **INC**
- R88M-K1K020T (-S2)/-K1K520T (-S2) **ABS**

• With brake

- R88M-K1K020H-B (S2)/-K1K520H-B (S2) **INC**
- R88M-K1K020T-B (S2)/-K1K520T-B (S2) **ABS**

Speed	Voltage	Motor capacity	Brake
2000r/min	200V	1/1.5kW	Without brake With brake

**CAD data**

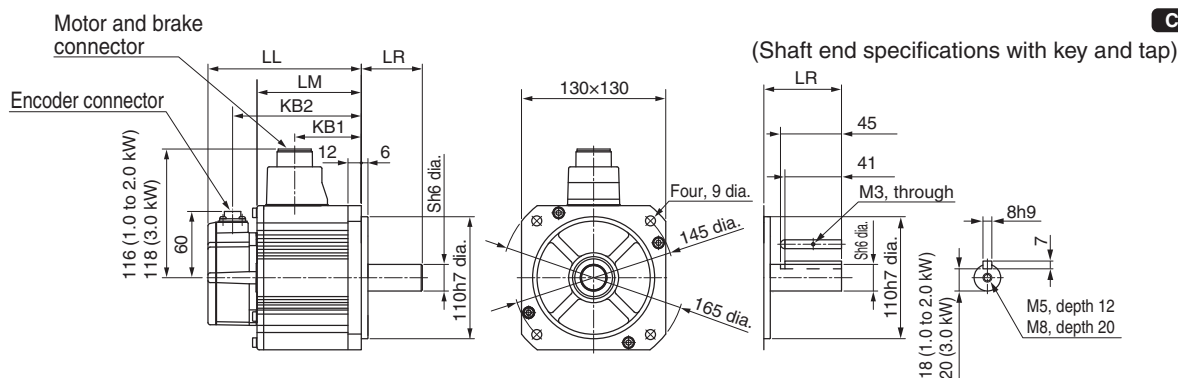

Model	Dimensions (mm)					
	LL	LR	LM	S	KB1	KB2
R88M-K1K020□	138	55	94	22	60	116
R88M-K1K520□	155.5	55	111.5	22	77.5	133.5
R88M-K1K020□-B□	163	55	119	22	60	141
R88M-K1K520□-B□	180.5	55	136.5	22	77.5	158.5

**Note:** The standard models have a straight shaft. A model with a key and tap is indicated by adding "S2" to the end of the model number.

# AC Servomotor/Drive OMNUC G5-series

## 2,000 r/min Servomotors (400 VAC)

400W/600W

**• Without brake**

- R88M-K40020F (-S2)/-K60020F (-S2) **INC**
- R88M-K40020C (-S2)/-K60020C (-S2) **ABS**

**• With brake**

- R88M-K40020F-B (S2)/-K60020F-B (S2) **INC**
- R88M-K40020C-B (S2)/-K60020C-B (S2) **ABS**

Speed	Voltage	Motor capacity	Brake
2000r/min	400V	400/600W	Without brake
			With brake

**CAD data**

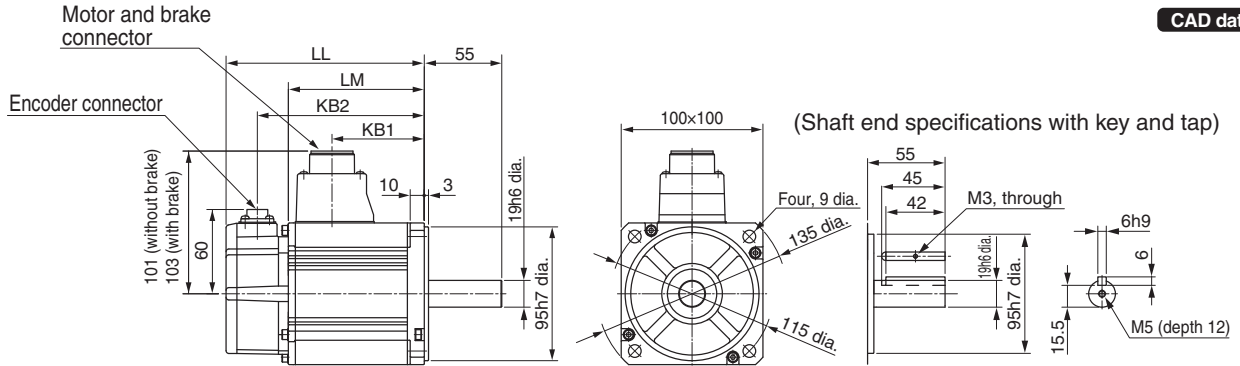

Model	Dimensions (mm)			
	LL	LM	KB1	KB2
R88M-K40020□	131.5	87.5	56.5	109.5
R88M-K60020□	141	97	66	119
R88M-K40020□-B□	158.5	114.5	53.5	136.5
R88M-K60020□-B□	168	124	63	146

**Note:** The standard models have a straight shaft. A model with a key and tap is indicated by adding "S2" to the end of the model number.

1kW/1.5kW

**• Without brake**

- R88M-K1K020F (-S2)/-K1K520F (-S2) **INC**
- R88M-K1K020C (-S2)/-K1K520C (-S2) **ABS**

**• With brake**

- R88M-K1K020F-B (S2)/-K1K520F-B (S2) **INC**
- R88M-K1K020C-B (S2)/-K1K520C-B (S2) **ABS**

Speed	Voltage	Motor capacity	Brake
2000r/min	400V	1/1.5kW	Without brake
			With brake

**CAD data**

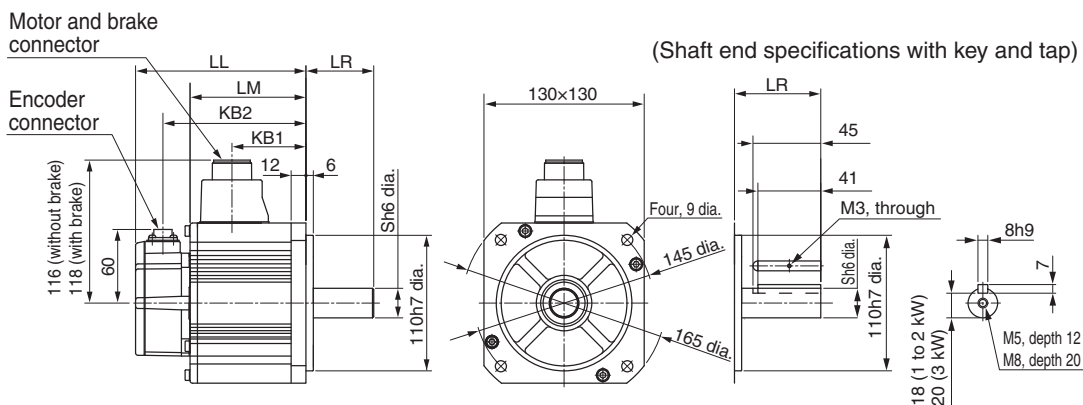

Model	Dimensions (mm)					
	LL	LR	LM	S	KB1	KB2
R88M-K1K020□	138	55	94	22	60	116
R88M-K1K520□	155.5	55	111.5	22	77.5	133.5
R88M-K1K020□-B□	163	55	119	22	57	141
R88M-K1K520□-B□	180.5	55	136.5	22	74.5	158.5

**Note:** The standard models have a straight shaft. A model with a key and tap is indicated by adding "S2" to the end of the model number.

## 1,000 r/min Servomotors (200 VAC)

900W

• Without brake

- R88M-K90010H (-S2) **INC**
- R88M-K90010T (-S2) **ABS**

• With brake

- R88M-K90010H-B (S2) **INC**
- R88M-K90010T-B (S2) **ABS**

Speed	Voltage	Motor capacity	Brake
1000r/min	200V	900W	Without brake
			With brake

CAD data

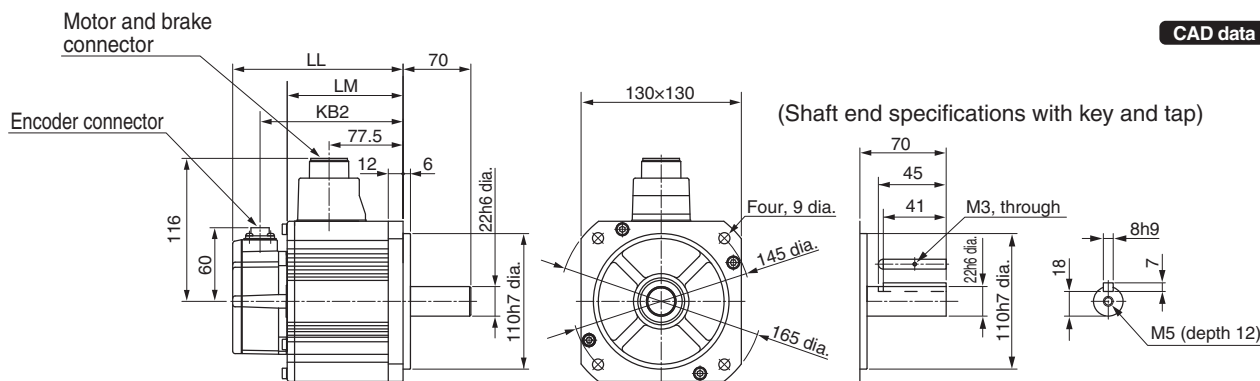

Model	Dimensions (mm)		
	LL	LM	KB2
R88M-K90010□	155.5	111.5	133.5
R88M-K90010□-B□	180.5	136.5	158.5

Note: The standard models have a straight shaft. A model with a key and tap is indicated by adding “S2” to the end of the model number.

## 1,000 r/min Servomotors (400 VAC)

900W

• Without brake

- R88M-K90010F (-S2) **INC**
- R88M-K90010C (-S2) **ABS**

• With brake

- R88M-K90010F-B (S2) **INC**
- R88M-K90010C-B (S2) **ABS**

Speed	Voltage	Motor capacity	Brake
1000r/min	400V	900W	Without brake
			With brake

CAD data

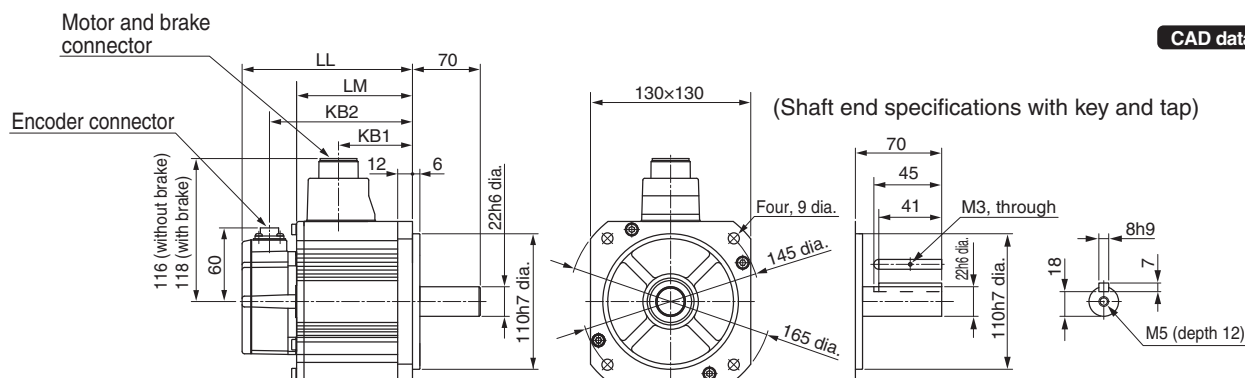

Model	Dimensions (mm)			
	LL	LM	KB1	KB2
R88M-K90010□	155.5	111.5	77.5	133.5
R88M-K90010□-B□	180.5	136.5	74.5	158.5

Note: The standard models have a straight shaft. A model with a key and tap is indicated by adding “S2” to the end of the model number.



---

# Ordering Information

---

AC Servomotors/Servo Drives with Built-in EtherCAT Communications  
Product name OMNUC G5-ML2-series

<b>Interpreting Model Numbers</b> .....	<b>32</b>
■ Servo Drive Model Numbers .....	32
■ Servomotor Model Numbers .....	32
■ Understanding Decelerator Model Numbers (Backlash = 3' Max./Backlash = 15' Max.) .....	33
<b>Table of Servomotor Variations</b> .....	<b>34</b>
<b>Ordering Information</b> .....	<b>35</b>
AC Servo Drives (EtherCAT Communications).....	35
Servomotors .....	35
Decelerators (Backlash = 3' Max./Backlash = 15' Max.) .....	39
Accessories and Cables .....	41
<b>Combination table</b> .....	<b>45</b>
■ Servo Drive and Servomotor Combinations.....	45
■ Servomotor and Decelerator Combinations.....	46
■ Cable Combinations .....	47
<b>About Manuals</b> .....	<b>50</b>
<b>Read and Understand this Catalog</b> .....	<b>51</b>



## Interpreting Model Numbers

### Servo Drives

**R88D-K N 01 H -ECT -R**

(1) (2) (3) (4) (5) (6)

No.	Item	Symbol	Specifications
(1)	OMNUC G5 Series Servo Drives		
(2)	Drive Type	N	Network
(3)	Maximum Applicable Servomotor Capacity	A5	50W
		01	100W
		02	200W
		04	400W
		06	600W
		08	750W
		10	1kW
(4)	Power Supply Voltage	Çk	AC100V
		H	AC200V
		F	AC400V
(5)	Communications Type	-ECT	EtherCAT
(6)	Model	-R	Model limited to connection to CJ1W-NC□81

### Servomotors

**R88M-K □ 750 30 H -BO S2**

(1) (2) (3) (4) (5) (6)

No.	Item	Symbol	Specifications
(1)	OMNUC G5-series Servomotor		
(2)	Motor Type	Blank	Cylinder type
		—	—
(3)	Applicable Servomotor Capacity	050	50W
		100	100W
		200	200W
		400	400W
		600	600W
		750	750W
		900	900W
		1K0	1kW
		1K5	1.5kW
		(4)	Rated Rotation Speed
20	2000r/min		
30	3000r/min		
(5)	Applied Voltage	F	400 VAC (incremental encoder) <b>INC</b>
		H	200 VAC (incremental encoder) <b>INC</b>
		L	100 VAC (incremental encoder) <b>INC</b>
		C	400 VAC (absolute encoder) <b>ABS/INC</b>
		T	200 VAC (absolute encoder) <b>ABS/INC</b>
		S	100 VAC (absolute encoder) <b>ABS/INC</b>
(6)	Options	Blank	Straight shaft
		B	With brake
		O	With oil seal
		S2	With key and tap

**Note:** **INC** incremental encoder: 20bit

**ABS/INC** incremental encoder: 17bit, absolute encoder: 17bit

Understanding Decelerator Model Numbers (Backlash = 3' Max./Backlash = 15' Max.)

Backlash = 3' Max.

**R88G-HPG 14A 05 100 S B J**

(1) (2) (3) (4) (5) (6) (7)

No	Item	Symbol	Specifications
(1)	Decelerator for G□-Series Servomotors Backlash = 3' Max.		
(2)	Flange Size Number	11B	□40
		14A	□60
		20A	□90
		32A	□120
		50A	□170
		65A	□230
(3)	Gear Ratio	05	1/5
		09	1/9 (only frame number 11B)
		11	1/11 (except frame number 65A)
		12	1/12 (only frame number 65A)
		20	1/20 (only frame number 65A)
		21	1/21 (except frame number 65A)
		25	1/25 (only frame number 65A)
		33	1/33
		45	1/45
		(4)	Applicable Servomotor Capacity
100	100 W		
200	200 W		
400	400 W		
750	750 W		
900	900 W		
1K0	1 kW		
1K5	1.5 kW		
2K0	2 kW		
3K0	3 kW		
4K0	4 kW		
4K5	4.5 kW		
5K0	5 kW		
(5)	Motor Type		
		-	-
		S	2,000-r/min cylindrical servomotors
		T	1,000-r/min cylindrical servomotors
(6)	Backlash	B	Backlash = 3' Max
(7)	Option	Blank	Straight shaft
		J	With key and tap

Backlash = 15' Max.

**R88G-VRSF 09 B 100 C J**

(1) (2) (3) (4) (5) (6) (7)

No	Item	Symbol	Specifications
(1)	Decelerator for G□-Series Servomotors Backlash = 15' Max.		
(2)	Gear Ratio	05	1/5
		09	1/9
		15	1/15
		25	1/25
(3)	Flange Size Number	B	□52
		C	□78
		D	□98
(4)	Applicable Servomotor Capacity	050	50 W
		100	100 W
		200	200 W
		400	400 W
		750	750 W
(5)	Motor Type	Blank	3,000-r/min cylindrical servomotors
(6)	Backlash	C	Backlash = 15' Max
(7)	Option	J	With key (without tap)

Table of Servomotor Variations

R88M-K□□□□□□□-□□□□  
(3) (4) (5) (6) (7) (8) (9)

(3) Type	(4) Applicable Servomotor Capacity	(5) Rotation speed	Model	(6) Applied Voltage						(7) With brake / Without brake		(8) Models with oil seals		(9) Shaft type		
				INC	INC	INC	ABS	ABS	ABS	-	B	Blank	O	Blank	S2	
				400	200	100	400	200	100							
				F	H	L	C	T	S							
Cylinder	50 W	3,000 r/min	R88M-K05030 *		●			●		●	●	●	●	●	●	
	100 W		R88M-K10030		●	●		●	●	●	●	●	●	●	●	●
	200 W		R88M-K20030		●	●		●	●	●	●	●	●	●	●	●
	400 W		R88M-K40030		●	●		●	●	●	●	●	●	●	●	●
	750 W		R88M-K75030	●	●		●	●		●	●	●	●	●	●	●
	1 kW		R88M-K1K030	●	●		●	●		●	●	●	●	●	●	●
	1.5 kW		R88M-K1K530	●	●		●	●		●	●	●	●	●	●	●
	400 W	2,000 r/min	R88M-K40020	●			●			●	●	●	●	●	●	●
	600 W		R88M-K60020	●			●			●	●	●	●	●	●	●
	1 kW		R88M-K1K020	●	●		●	●		●	●	●	●	●	●	●
	1.5 kW		R88M-K1K520	●	●		●	●		●	●	●	●	●	●	●
	900 W		1,000 r/min	R88M-K90010	●	●		●	●		●	●	●	●	●	●
	Blank: Cylinder type	example 030: 30 W 100: 100 W 1K0: 1 kW	10: 1,000 r/min 20: 2,000 r/min 30: 3,000 r/min		F: 400 VAC (with incremental encoder) <b>INC</b> H: 200 VAC (with incremental encoder) <b>INC</b> L: 100 VAC (with incremental encoder) <b>INC</b> C: 400 VAC (with absolute encoder) <b>ABS/INC</b> T: 200 VAC (with absolute encoder) <b>ABS/INC</b> S: 100 VAC (with absolute encoder) <b>ABS/INC</b>						Blank: Without brake B: 24 VDC With brake		Blank: Without oil seals O: With oil seals		Blank: Straight shaft S2: With key and tap	

\* R88M-K05030H-□, R88M-K05030T-□, can be used for Power Supply Voltage of 100/200VAC.

## Ordering Information

### AC Servo Drives

#### EtherCAT Communications

Specifications		Model
Power Supply Voltage	Applicable Servomotor Capacity	
Single-phase 100 VAC	50W	R88D-KNA5L-ECT-R <i>NEW</i>
	100W	R88D-KN01L-ECT-R <i>NEW</i>
	200W	R88D-KN02L-ECT-R <i>NEW</i>
	400W	R88D-KN04L-ECT-R <i>NEW</i>
Single-phase/ Three-phase 200 VAC	100W	R88D-KN01H-ECT-R <i>NEW</i>
	200W	R88D-KN02H-ECT-R <i>NEW</i>
	400W	R88D-KN04H-ECT-R <i>NEW</i>
	750W	R88D-KN08H-ECT-R <i>NEW</i>
	1kW	R88D-KN10H-ECT-R <i>NEW</i>
Three-phase 400 VAC	1.5kW	R88D-KN15H-ECT-R <i>NEW</i>
	600W	R88D-KN06F-ECT-R <i>NEW</i>
	1kW	R88D-KN10F-ECT-R <i>NEW</i>
	1.5kW	R88D-KN15F-ECT-R <i>NEW</i>

### Servomotors

#### <Cylinder Type>

#### ● 3,000-r/min servomotors

Rotation speed	Encoder	Option
3,000 r/min	INC	Without key
	ABS/INC	With key

Specifications		Model	
Voltage	Rated output	With incremental encoder	
		Straight shaft without key	
		Without oil seals	
Without brake	100 V	50 W	R88M-K05030H
		100 W	R88M-K10030L
		200 W	R88M-K20030L
		400 W	R88M-K40030L
	200 V	50 W	R88M-K05030H
		100 W	R88M-K10030H
		200 W	R88M-K20030H
		400 W	R88M-K40030H
		750 W	R88M-K75030H
	400 V	1 kW	R88M-K1K030H
		1.5 kW	R88M-K1K530H
		750 W	R88M-K75030F
With brake	100 V	50 W	R88M-K05030H-B
		100 W	R88M-K10030L-B
		200 W	R88M-K20030L-B
		400 W	R88M-K40030L-B
	200 V	50 W	R88M-K05030H-B
		100 W	R88M-K10030H-B
400 V	200 W	R88M-K20030H-B	
	400 W	R88M-K40030H-B	
	750 W	R88M-K75030H-B	
	1 kW	R88M-K1K030H-B	
	1.5 kW	R88M-K1K530H-B	

Note: Models with oil seals are also available.

Rotation speed	Encoder	Option
3000r/min	INC	Without key
	ABS/INC	With key

Specifications		Model	
Voltage	Rated output	With incremental encoder	
		Straight shaft with key and tap	
		Without oil seals	
Without brake	100 V	50 W	R88M-K05030H-S2
		100 W	R88M-K10030L-S2
		200 W	R88M-K20030L-S2
		400 W	R88M-K40030L-S2
	200 V	50 W	R88M-K05030H-S2
		100 W	R88M-K10030H-S2
		200 W	R88M-K20030H-S2
		400 W	R88M-K40030H-S2
		750 W	R88M-K75030H-S2
	400 V	1 kW	R88M-K1K030H-S2
		1.5 kW	R88M-K1K530H-S2
		750 W	R88M-K75030F-S2
With brake	100 V	50 W	R88M-K05030H-BS2
		100 W	R88M-K10030L-BS2
		200 W	R88M-K20030L-BS2
		400 W	R88M-K40030L-BS2
	200 V	50 W	R88M-K05030H-BS2
		100 W	R88M-K10030H-BS2
400 V	200 W	R88M-K20030H-BS2	
	400 W	R88M-K40030H-BS2	
	750 W	R88M-K75030H-BS2	
	1 kW	R88M-K1K030H-BS2	
	1.5 kW	R88M-K1K530H-BS2	

Note: Models with oil seals are also available.

# AC Servomotor/Drive OMNUC G5-series

Rotation speed	Encoder	Option
3000r/min	INC	Without key
	ABS/INC	With key

Specifications			Model	
			With absolute encoder	
			Straight shaft without key	
Voltage	Rated output	Without oil seals		
Without brake	100 V	50 W	R88M-K05030T	
		100 W	R88M-K10030S	
		200 W	R88M-K20030S	
		400 W	R88M-K40030S	
	200 V	50 W	R88M-K05030T	
		100 W	R88M-K10030T	
		200 W	R88M-K20030T	
		400 W	R88M-K40030T	
		750 W	R88M-K75030T	
		1 kW	R88M-K1K030T	
	400 V	1.5 kW	R88M-K1K530T	
		750 W	R88M-K75030C	
1 kW		R88M-K1K030C		
With brake	100 V	50 W	R88M-K05030T-B	
		100 W	R88M-K10030S-B	
		200 W	R88M-K20030S-B	
		400 W	R88M-K40030S-B	
	200 V	50 W	R88M-K05030T-B	
		100 W	R88M-K10030T-B	
		200 W	R88M-K20030T-B	
		400 W	R88M-K40030T-B	
		750 W	R88M-K75030T-B	
		1 kW	R88M-K1K030T-B	
	400 V	1.5 kW	R88M-K1K530T-B	
		750 W	R88M-K75030C-B	
1 kW		R88M-K1K030C-B		
		1.5 kW	R88M-K1K530C-B	

Note: Models with oil seals are also available.

Rotation speed	Encoder	Option
3000r/min	INC	Without key
	ABS/INC	With key

Specifications			Model	
			With absolute encoder	
			Straight shaft withkey and tap	
Voltage	Rated output	Without oil seals		
Without brake	100 V	50 W	R88M-K05030T-S2	
		100 W	R88M-K10030S-S2	
		200 W	R88M-K20030S-S2	
		400 W	R88M-K40030S-S2	
	200 V	50 W	R88M-K05030T-S2	
		100 W	R88M-K10030T-S2	
		200 W	R88M-K20030T-S2	
		400 W	R88M-K40030T-S2	
		750 W	R88M-K75030T-S2	
		1 kW	R88M-K1K030T-S2	
	400 V	1.5 kW	R88M-K1K530T-S2	
		750 W	R88M-K75030C-S2	
1 kW		R88M-K1K030C-S2		
With brake	100 V	50 W	R88M-K05030T-BS2	
		100 W	R88M-K10030S-BS2	
		200 W	R88M-K20030S-BS2	
		400 W	R88M-K40030S-BS2	
	200 V	50 W	R88M-K05030T-BS2	
		100 W	R88M-K10030T-BS2	
		200 W	R88M-K20030T-BS2	
		400 W	R88M-K40030T-BS2	
		750 W	R88M-K75030T-BS2	
		1 kW	R88M-K1K030T-BS2	
	400 V	1.5 kW	R88M-K1K530T-BS2	
		750 W	R88M-K75030C-BS2	
1 kW		R88M-K1K030C-BS2		
		1.5 kW	R88M-K1K530C-BS2	

Note: Models with oil seals are also available.

## ● 2,000-r/min servomotors

Rotation speed	Encoder	Option
2000r/min	INC	Without key
	ABS/INC	With key

Specifications			Model
			With incremental encoder
			Straight shaft without key
Voltage	Rated output	Without oil seals	
		Without brake	200 V
1.5 kW	R88M-K1K520H		
400 V	400 W		R88M-K40020F
	600 W		R88M-K60020F
	1 kW		R88M-K1K020F
	1.5 kW		R88M-K1K520F
With brake	200 V	1 kW	R88M-K1K020H-B
		1.5 kW	R88M-K1K520H-B
	400 V	400 W	R88M-K40020F-B
		600 W	R88M-K60020F-B
		1 kW	R88M-K1K020F-B
		1.5 kW	R88M-K1K520F-B

**Note:** Models with oil seals are also available.

Rotation speed	Encoder	Option
2000r/min	INC	Without key
	ABS/INC	With key

Specifications			Model
			With absolute encoder
			Straight shaft without key
Voltage	Rated output	Without oil seals	
		Without brake	200 V
1.5 kW	R88M-K1K520T		
400 V	400 W		R88M-K40020C
	600 W		R88M-K60020C
	1 kW		R88M-K1K020C
	1.5 kW		R88M-K1K520C
With brake	200 V	1 kW	R88M-K1K020T-B
		1.5 kW	R88M-K1K520T-B
	400 V	400 W	R88M-K40020C-B
		600 W	R88M-K60020C-B
		1 kW	R88M-K1K020C-B
		1.5 kW	R88M-K1K520C-B

**Note:** Models with oil seals are also available.

Rotation speed	Encoder	Option
2000r/min	INC	Without key
	ABS/INC	With key

Specifications			Model
			With incremental encoder
			Straight shaft with key and tap
Voltage	Rated output	Without oil seals	
		Without brake	200 V
1.5 kW	R88M-K1K520H-S2		
400 V	400 W		R88M-K40020F-S2
	600 W		R88M-K60020F-S2
	1 kW		R88M-K1K020F-S2
	1.5 kW		R88M-K1K520F-S2
With brake	200 V	1 kW	R88M-K1K020H-BS2
		1.5 kW	R88M-K1K520H-BS2
	400 V	400 W	R88M-K40020F-BS2
		600 W	R88M-K60020F-BS2
		1 kW	R88M-K1K020F-BS2
		1.5 kW	R88M-K1K520F-BS2

**Note:** Models with oil seals are also available.

Rotation speed	Encoder	Option
2000r/min	INC	Without key
	ABS/INC	With key

Specifications			Model
			With absolute encoder
			Straight shaft with key and tap
Voltage	Rated output	Without oil seals	
		Without brake	200 V
1.5 kW	R88M-K1K520T-S2		
400 V	400 W		R88M-K40020C-S2
	600 W		R88M-K60020C-S2
	1 kW		R88M-K1K020C-S2
	1.5 kW		R88M-K1K520C-S2
With brake	200 V	1 kW	R88M-K1K020T-BS2
		1.5 kW	R88M-K1K520T-BS2
	400 V	400 W	R88M-K40020C-BS2
		600 W	R88M-K60020C-BS2
		1 kW	R88M-K1K020C-BS2
		1.5 kW	R88M-K1K520C-BS2

**Note:** Models with oil seals are also available.

# AC Servomotor/Drive OMNUC G5-series

## ● 1,000-r/min servomotors

Rotation speed	Encoder	Option
1000r/min	INC	Without key
	ABS/INC	With key

Specifications			Model
			With incremental encoder
			Straight shaft without key
	Voltage	Rated output	Without oil seals
Without brake	200 V	900 W	R88M-K90010H
	400 V	900 W	R88M-K90010F
With brake	200 V	900 W	R88M-K90010H-B
	400 V	900 W	R88M-K90010F-B

**Note:** Models with oil seals are also available.

Rotation speed	Encoder	Option
1000r/min	INC	Without key
	ABS/INC	With key

Specifications			Model
			With absolute encoder
			Straight shaft without key
	Voltage	Rated output	Without oil seals
Without brake	200 V	900 W	R88M-K90010T
	400 V	900 W	R88M-K90010C
With brake	200 V	900 W	R88M-K90010T-B
	400 V	900 W	R88M-K90010C-B

**Note:** Models with oil seals are also available.

Rotation speed	Encoder	Option
1000r/min	INC	Without key
	ABS/INC	With key

Specifications			Model
			With incremental encoder
			Straight shaft with key and tap
	Voltage	Rated output	Without oil seals
Without brake	200 V	900 W	R88M-K90010H-S2
	400 V	900 W	R88M-K90010F-S2
With brake	200 V	900 W	R88M-K90010H-BS2
	400 V	900 W	R88M-K90010F-BS2

**Note:** Models with oil seals are also available.

Rotation speed	Encoder	Option
1000r/min	INC	Without key
	ABS/INC	With key

Specifications			Model
			With absolute encoder
			Straight shaft with key and tap
	Voltage	Rated output	Without oil seals
Without brake	200 V	900 W	R88M-K90010T-S2
	400 V	900 W	R88M-K90010C-S2
With brake	200 V	900 W	R88M-K90010T-BS2
	400 V	900 W	R88M-K90010C-BS2

**Note:** Models with oil seals are also available.

**Decelerators (Backlash = 3' Max./Backlash = 15' Max.)**

Backlash = 3' Max  
<Cylinder Type>

● 3,000-r/min servomotors

Straight shaft without key

Motor capacity	Gear Ratio	Model (Straight shaft)
50 W	1/5	R88G-HPG11B05100B
	1/9	R88G-HPG11B09050B
	1/21	R88G-HPG14A21100B
	1/33	R88G-HPG14A33050B
	1/45	R88G-HPG14A45050B
100 W	1/5	R88G-HPG11B05100B
	1/11	R88G-HPG14A11100B
	1/21	R88G-HPG14A21100B
	1/33	R88G-HPG20A33100B
	1/45	R88G-HPG20A45100B
200 W	1/5	R88G-HPG14A05200B
	1/11	R88G-HPG14A11200B
	1/21	R88G-HPG20A21200B
	1/33	R88G-HPG20A33200B
	1/45	R88G-HPG20A45200B
400 W	1/5	R88G-HPG14A05400B
	1/11	R88G-HPG20A11400B
	1/21	R88G-HPG20A21400B
	1/33	R88G-HPG32A33400B
	1/45	R88G-HPG32A45400B
750 W (200 V)	1/5	R88G-HPG20A05750B
	1/11	R88G-HPG20A11750B
	1/21	R88G-HPG32A21750B
	1/33	R88G-HPG32A33750B
	1/45	R88G-HPG32A45750B
750W (400 V)	1/5	R88G-HPG32A052K0B
	1/11	R88G-HPG32A112K0B
	1/21	R88G-HPG32A211K5B
	1/33	R88G-HPG32A33600SB
	1/45	R88G-HPG50A451K5B
1kW	1/5	R88G-HPG32A052K0B
	1/11	R88G-HPG32A112K0B
	1/21	R88G-HPG32A211K5B
	1/33	R88G-HPG32A33600SB
	1/45	R88G-HPG50A451K5B
1.5kW	1/5	R88G-HPG32A052K0B
	1/11	R88G-HPG32A112K0B
	1/21	R88G-HPG32A211K5B
	1/33	R88G-HPG50A332K0B
	1/45	R88G-HPG50A451K5B

**Note:** 1. The standard models have a straight shaft.  
2. To order a Servomotor with a straight shaft with key, add "J" to the end of the model number, in the place indicated by the box.

● 2,000-r/min servomotors

Straight shaft without key

Motor capacity	Gear Ratio	Model (Straight shaft)
400 W	1/5	R88G-HPG32A052K0B
	1/11	R88G-HPG32A112K0B
	1/21	R88G-HPG32A211K5B
	1/33	R88G-HPG32A33600SB
	1/45	R88G-HPG32A45400SB
600 W	1/5	R88G-HPG32A052K0B
	1/11	R88G-HPG32A112K0B
	1/21	R88G-HPG32A211K5B
	1/33	R88G-HPG32A33600SB
	1/45	R88G-HPG50A451K5B
1 kW	1/5	R88G-HPG32A053K0B
	1/11	R88G-HPG32A112K0SB
	1/21	R88G-HPG32A211K0SB
	1/33	R88G-HPG50A332K0SB
	1/45	R88G-HPG50A451K0SB
1.5 kW	1/5	R88G-HPG32A053K0B
	1/11	R88G-HPG32A112K0SB
	1/21	R88G-HPG50A213K0B
	1/33	R88G-HPG50A332K0SB

**Note:** 1. The standard models have a straight shaft.  
2. To order a Servomotor with a straight shaft with key, add "J" to the end of the model number, in the place indicated by the box.



● 1,000-r/min servomotors

Straight shaft without key

Motor capacity	Gear Ratio	Model (Straight shaft)
900 W	1/5	R88G-HPG32A053K0B
	1/11	R88G-HPG32A112K0SB
	1/21	R88G-HPG50A213K0B
	1/33	R88G-HPG50A332K0SB

- Note:** 1. The standard models have a straight shaft.  
2. To order a Servomotor with a straight shaft with key, add "J" to the end of the model number, in the place indicated by the box.

Backlash = 15' Max  
<Cylinder Type>

● 3,000-r/min servomotors

Straight shaft with key

Motor capacity	Gear Ratio	Model (Straight shaft)
50 W	1/5	R88G-VRSF05B100CJ
	1/9	R88G-VRSF09B100CJ
	1/15	R88G-VRSF15B100CJ
	1/25	R88G-VRSF25B100CJ
100 W	1/5	R88G-VRSF05B100CJ
	1/9	R88G-VRSF09B100CJ
	1/15	R88G-VRSF15B100CJ
	1/25	R88G-VRSF25B100CJ
200 W	1/5	R88G-VRSF05B200CJ
	1/9	R88G-VRSF09C200CJ
	1/15	R88G-VRSF15C200CJ
400 W	1/25	R88G-VRSF25C200CJ
	1/5	R88G-VRSF05C400CJ
	1/9	R88G-VRSF09C400CJ
750 W	1/15	R88G-VRSF15C400CJ
	1/25	R88G-VRSF25C400CJ
	1/5	R88G-VRSF05C750CJ
750 W	1/9	R88G-VRSF09D750CJ
	1/15	R88G-VRSF15D750CJ
	1/25	R88G-VRSF25D750CJ

## Accessories and Cables

### ■ Connection Cables (Power Cables, Brake Cables, Encoder Cables)

#### <Standard Cables>

##### Power cable

Specifications		Without brake		With brake	
		Model		Model	
[100 V/200 V] 3,000-r/min Servomotors of 50 to 750 W	3 m	R88A-CAKA003S		<b>Note:</b> There are separate connectors for power and brakes for 3,000-r/min Servomotors of 50 to 750W. When a Servomotor with a brake is used, it is necessary to use both a PowerCable for Servomotors without brakes and Power cable.	
	5 m	R88A-CAKA005S			
	10 m	R88A-CAKA010S			
	15m	R88A-CAKA015S			
	20 m	R88A-CAKA020S			
	30 m	R88A-CAKA030S			
	40 m	R88A-CAKA040S			
	50 m	R88A-CAKA050S			
[200 V] 3,000-r/min Servomotors of 1 to 1.5 kW 2,000-r/min Servomotors of 1 to 1.5 kW 1,000-r/min Servomotors of 900 W	3 m	R88A-CAGB003S		R88A-CAGB003B	
	5 m	R88A-CAGB005S		R88A-CAGB005B	
	10 m	R88A-CAGB010S		R88A-CAGB010B	
	15 m	R88A-CAGB015S		R88A-CAGB015B	
	20 m	R88A-CAGB020S		R88A-CAGB020B	
	30 m	R88A-CAGB030S		R88A-CAGB030B	
	40 m	R88A-CAGB040S		R88A-CAGB040B	
	50 m	R88A-CAGB050S		R88A-CAGB050B	
[400 V] 3,000-r/min Servomotors of 750 W to 1.5 kW 2,000-r/min Servomotors of 400 W to 1.5 kW 1,000-r/min Servomotors of 900 W	3 m	R88A-CAGB003S		R88A-CAKF003B	
	5 m	R88A-CAGB005S		R88A-CAKF005B	
	10 m	R88A-CAGB010S		R88A-CAKF010B	
	15 m	R88A-CAGB015S		R88A-CAKF015B	
	20 m	R88A-CAGB020S		R88A-CAKF020B	
	30 m	R88A-CAGB030S		R88A-CAKF030B	
	40 m	R88A-CAGB040S		R88A-CAKF040B	
	50 m	R88A-CAGB050S		R88A-CAKF050B	

##### Brake Cable

Specifications		Standard Cables	
		Model	
[100 V][200 V] 3,000-r/min Servomotors of 50 to 750 W	3 m	R88A-CAKA003B	
	5 m	R88A-CAKA005B	
	10 m	R88A-CAKA010B	
	15 m	R88A-CAKA015B	
	20 m	R88A-CAKA020B	
	30 m	R88A-CAKA030B	
	40 m	R88A-CAKA040B	
	50 m	R88A-CAKA050B	

##### Encoder Cable

Specifications		Standard Cables	
		Model	
[100 V/200 V] 3,000-r/min Servomotors of 50 to 750 W	3 m	R88A-CRKA003C	
	5 m	R88A-CRKA005C	
	10 m	R88A-CRKA010C	
	15 m	R88A-CRKA015C	
	20 m	R88A-CRKA020C	
	30 m	R88A-CRKA030C	
	40 m	R88A-CRKA040C	
	50 m	R88A-CRKA050C	
[400V] 3,000-r/min Servomotors 2,000-r/min Servomotors 1,000-r/min Servomotors [200V] 3,000-r/min Servomotors of 1kW to 1.5kW 2,000-r/min Servomotors 1,000-r/min Servomotors	3 m	R88A-CRKC003N	
	5 m	R88A-CRKC005N	
	10 m	R88A-CRKC010N	
	15 m	R88A-CRKC015N	
	20 m	R88A-CRKC020N	
	30 m	R88A-CRKC030N	
	40 m	R88A-CRKC040N	
	50 m	R88A-CRKC050N	

## <Robot Cables>

### Power cable

Specifications		Without brake		With brake	
		Model		Model	
[100 V/200 V] 3,000-r/min Servomotors of 50 to 750 W	3 m	R88A-CAKA003SR	<b>Note:</b> There are separate connectors for power and brakes for 3,000-r/min Servomotors of 50 to 750W. When a Servomotor with a brake is used, it is necessary to use both a PowerCable for Servomotors without brakes and Power cable.		
	5 m	R88A-CAKA005SR			
	10 m	R88A-CAKA010SR			
	15 m	R88A-CAKA015SR			
	20 m	R88A-CAKA020SR			
	30 m	R88A-CAKA030SR			
	40 m	R88A-CAKA040SR			
	50 m	R88A-CAKA050SR			
[200 V] 3,000-r/min Servomotors of 1 to 1.5 kW 2,000-r/min Servomotors of 1 to 1.5 kW 1,000-r/min Servomotors of 900 W	3 m	R88A-CAGB003SR	R88A-CAGB003BR		
	5 m	R88A-CAGB005SR	R88A-CAGB005BR		
	10 m	R88A-CAGB010SR	R88A-CAGB010BR		
	15 m	R88A-CAGB015SR	R88A-CAGB015BR		
	20 m	R88A-CAGB020SR	R88A-CAGB020BR		
	30 m	R88A-CAGB030SR	R88A-CAGB030BR		
	40 m	R88A-CAGB040SR	R88A-CAGB040BR		
[400 V] 3,000-r/min Servomotors of 750 W to 1.5 kW 2,000-r/min Servomotors of 400 W to 1.5 kW 1,000-r/min Servomotors of 900 W	3 m	R88A-CAGB003SR	R88A-CAKF003BR		
	5 m	R88A-CAGB005SR	R88A-CAKF005BR		
	10 m	R88A-CAGB010SR	R88A-CAKF010BR		
	15 m	R88A-CAGB015SR	R88A-CAKF015BR		
	20 m	R88A-CAGB020SR	R88A-CAKF020BR		
	30 m	R88A-CAGB030SR	R88A-CAKF030BR		
	40 m	R88A-CAGB040SR	R88A-CAKF040BR		
	50 m	R88A-CAGB050SR	R88A-CAKF050BR		

### Brake Cable

Specifications		Robot Cables	
		Model	
[100 V] [200 V] 3,000-r/min Servomotors of 50 to 750 W	3 m	R88A-CAKA003BR	
	5 m	R88A-CAKA005BR	
	10 m	R88A-CAKA010BR	
	15 m	R88A-CAKA015BR	
	20 m	R88A-CAKA020BR	
	30 m	R88A-CAKA030BR	
	40 m	R88A-CAKA040BR	
	50 m	R88A-CAKA050BR	

### Encoder Cable

Specifications		Robot Cables	
		Model	
[100 V/200 V] 3,000-r/min Servomotors of 50 to 750 W	3 m	R88A-CRKA003CR	
	5 m	R88A-CRKA005CR	
	10 m	R88A-CRKA010CR	
	15 m	R88A-CRKA015CR	
	20 m	R88A-CRKA020CR	
	30 m	R88A-CRKA030CR	
	40 m	R88A-CRKA040CR	
	50 m	R88A-CRKA050CR	
[400V] 3,000-r/min Servomotors 2,000-r/min Servomotors 1,000-r/min Servomotors [200V] 3,000-r/min Servomotors of 1kW to 1.5kW 2,000-r/min Servomotors 1,000-r/min Servomotors	3 m	R88A-CRKC003NR	
	5 m	R88A-CRKC005NR	
	10 m	R88A-CRKC010NR	
	15 m	R88A-CRKC015NR	
	20 m	R88A-CRKC020NR	
	30 m	R88A-CRKC030NR	
	40 m	R88A-CRKC040NR	
	50 m	R88A-CRKC050NR	

■ Cable/Connector

Absolute Encoder Battery Cable

Name	Length	model
Absolute Encoder Battery Cable (Battery not included)	0.3 m	R88A-CRGD0R3C
Absolute Encoder Battery Cable (One R88A-BAT01G Battery included)	0.3 m	R88A-CRGD0R3C-BS

Absolute Encoder Backup Battery

Specifications	Model
2,000 mA • 3.6 V	R88A-BAT01G

Analog Monitor Cable

Name	Length	Model
Analog Monitor Cable	1 m	R88A-CMK001S

Servomotor Connector

Name	Applicable Servomotor Capacity	Model
	[100 V/200 V] 3,000 r/min (50 to 750 W)	
Servomotor Connector for Encoder Cable	[100 V/200 V] 3,000 r/min (1 to 1.5 kW), 2,000 r/min, 1,000 r/min [400 V] 3,000 r/min, 2,000 r/min, 1,000 r/min	R88A-CNK04R
	(750 W max.)	R88A-CNK11A
Power Cable Connector	(750 W max.)	R88A-CNK11B

■ Control Cables

Control Cables

Name	Specifications	Model
Connector Terminal Block Cables	Length 1.0 m	XW2Z-100J-B34
	Length 2.0 m	XW2Z-200J-B34
Connector Terminal Block	Conversion Unit for General-purpose Controllers (M3 screws) Through type	XW2B-20G4
	Conversion Unit for General-purpose Controllers (M3.5 screws) Through type	XW2B-20G5
	Conversion Unit for General-purpose Controllers (M3 screws) Slim type	XW2D-20G6

Servo Drive Connectors (common)

Name	Connects to	Model
Encoder Connector	CN2	R88A-CNW01R
External Scale Connector	CN4	R88A-CNK41L
Safety Connector	CN8	R88A-CNK81S

Servo Drive Connectors (EtherCAT Communications)

Name	Connects to	Model
Control I/O Connector	CN1	R88A-CNW01C

## ■ Peripheral Devices (External Regeneration Resistors, Reactors, Mounting Brackets)

### External Regeneration Resistors

Specifications	Model
80 W 50 Ω	R88A-RR08050S
80 W 100 Ω	R88A-RR080100S
220 W 47 Ω	R88A-RR22047S1
500 W 20 Ω	R88A-RR50020S

### Reactors

Specifications	Model
EtherCAT Communications	
R88D-KNA5L-ECT-R/-KN01H-ECT-R	3G3AX-DL2002
R88D-KN01L-ECT-R/-KN02H-ECT-R	3G3AX-DL2004
R88D-KN02L-ECT-R/-KN04H-ECT-R	3G3AX-DL2007
R88D-KN04L-ECT-R/-KN08H-ECT-R/ -KN10H-ECT-R	3G3AX-DL2015
R88D-KN15H-ECT-R	3G3AX-DL2022
R88D-KN08H-ECT-R/-KN10H-ECT-R/ -KN15H-ECT-R/-KN06F-ECT-R/ -KN10F-ECT-R/-KN15F-ECT-R	3G3AX-AL2025

### Mounting Brackets (L Brackets for Rack Mounting)

Specifications	Model
EtherCAT Communications	
R88D-KNA5L-ECT-R/-KN01L-ECT-R/ -KN01H-ECT-R/-KN02H-ECT-R	R88A-TK01K
R88D-KN02L-ECT-R/-KN04H-ECT-R	R88A-TK02K
R88D-KN04L-ECT-R/-KN08H-ECT-R	R88A-TK03K
R88D-KN10H-ECT-R/-KN15H-ECT-R/ -KN06F-ECT-R/-KN10F-ECT-R/ -KN15F-ECT-R	R88A-TK04K

### ■ Support Software

Product name	Specifications			Model
		Number of licenses	Media	
CX-One FA Integrated Tool Package Ver. 4.□	The CX-One is a package that integrates Support Software for OMRON PLCs and components. CX-One runs on the following OS. OS: Windows 2000 (Service Pack 4 or higher), XP, Vista, or 7 * Except for 64-bit version. CX-One Ver.4.□ includes CX-Drive Ver.1.□. For details, refer to the CX-One catalog (Cat. No. R134).	1 license (See. Note 1.)	CD	CXONE-AL01C-V4 <b><i>NEW</i></b>
			DVD	CXONE-AL01D-V4 <b><i>NEW</i></b>

**Note: 1.** Multi licenses are available for the CX-One (3, 10, 30, or 50 licenses).

## Combination table

### Servo Drive and Servomotor Combinations (3,000 r/min, 2,000 r/min, 1,000 r/min)

<Cylinder Type>

#### ● 3,000-r/min servomotors and Servo Drives

Voltage	Servo Drive	Servomotor		
		Rated output	With incremental encoder	With absolute encoder
Single-phase 100 V	R88D-KNA5L-ECT-R	50 W	R88M-K05030H-□	R88M-K05030T-□
	R88D-KN01L-ECT-R	100 W	R88M-K10030L-□	R88M-K10030S-□
	R88D-KN02L-ECT-R	200 W	R88M-K20030L-□	R88M-K20030S-□
	R88D-KN04L-ECT-R	400 W	R88M-K40030L-□	R88M-K40030S-□
Single-phase/3-phase 200 V	R88D-KN01H-ECT-R	50 W	R88M-K05030H-□	R88M-K05030T-□
	R88D-KN01H-ECT-R	100 W	R88M-K10030H-□	R88M-K10030T-□
	R88D-KN02H-ECT-R	200 W	R88M-K20030H-□	R88M-K20030T-□
	R88D-KN04H-ECT-R	400 W	R88M-K40030H-□	R88M-K40030T-□
	R88D-KN08H-ECT-R	750 W	R88M-K75030H-□	R88M-K75030T-□
	R88D-KN15H-ECT-R	1 kW	R88M-K1K030H-□	R88M-K1K030T-□
	R88D-KN15H-ECT-R	1.5 kW	R88M-K1K530H-□	R88M-K1K530T-□
3-phase 400 V	R88D-KN10F-ECT-R	750 W	R88M-K75030F-□	R88M-K75030C-□
	R88D-KN15F-ECT-R	1 kW	R88M-K1K030F-□	R88M-K1K030C-□
	R88D-KN15F-ECT-R	1.5 kW	R88M-K1K530F-□	R88M-K1K530C-□

#### ● 2,000-r/min Servomotors and Servo Drives

Voltage	Servo Drive	Servomotor		
		Rated output	With incremental encoder	With absolute encoder
Single-phase/3-phase 200 V	R88D-KN10H-ECT-R	1 kW	R88M-K1K020H-□	R88M-K1K020T-□
	R88D-KN15H-ECT-R	1.5 kW	R88M-K1K520H-□	R88M-K1K520T-□
3-phase 400 V	R88D-KN06F-ECT-R	400 W	R88M-K40020F-□	R88M-K40020C-□
	R88D-KN06F-ECT-R	600 W	R88M-K60020F-□	R88M-K60020C-□
	R88D-KN10F-ECT-R	1 kW	R88M-K1K020F-□	R88M-K1K020C-□
	R88D-KN15F-ECT-R	1.5 kW	R88M-K1K520F-□	R88M-K1K520C-□

#### ● 1,000-r/min Servomotors and Servo Drives

Voltage	Servo Drive	Servomotor		
		Rated output	With incremental encoder	With absolute encoder
Single-phase/3-phase 200 V	R88D-KN15H-ECT-R	900 W	R88M-K90010H-□	R88M-K90010T-□
Single-phase/3-phase 400 V	R88D-KN15F-ECT-R	900 W	R88M-K90010F-□	R88M-K90010C-□

OMNUC G5-Series  
System Configuration

AC Servo Drives with Built-in  
EtherCAT Communications

Servomotors

Ordering Information

**Servomotor and Decelerator Combinations (3,000 r/min, 2,000 r/min, 1,000 r/min)**

<Cylinder Type>

● **3,000-r/min servomotors**

Motor model	1/5	1/11 (1/9 for flange size No.11)	1/21	1/33	1/45
R88M-K05030□	R88G-HPG11B05100B□ (Also used with R88M-K10030□)	R88G-HPG11B09050B□ (Gear ratio 1/9)	R88G-HPG14A21100B□ (Also used with R88M-K10030□)	R88G-HPG14A33050B□	R88G-HPG14A45050B□
R88M-K10030□	R88G-HPG11B05100B□	R88G-HPG14A11100B□	R88G-HPG14A21100B□	R88G-HPG20A33100B□	R88G-HPG20A45100B□
R88M-K20030□	R88G-HPG14A05200B□	R88G-HPG14A11200B□	R88G-HPG20A21200B□	R88G-HPG20A33200B□	R88G-HPG20A45200B□
R88M-K40030□	R88G-HPG14A05400B□	R88G-HPG20A11400B□	R88G-HPG20A21400B□	R88G-HPG32A33400B□	R88G-HPG32A45400B□
R88M-K75030H/T (200 V)	R88G-HPG20A05750B□	R88G-HPG20A11750B□	R88G-HPG32A21750B□	R88G-HPG32A33750B□	R88G-HPG32A45750B□
R88M-K75030F/C (400 V)	R88G-HPG32A052K0B□ (Also used with R88M-K2K030□)	R88G-HPG32A112K0B□ (Also used with R88M-K2K030□)	R88G-HPG32A211K5B□ (Also used with R88M-K1K5030□)	R88G-HPG32A33600SB□ (Also used with R88M-K60020□)	R88G-HPG50A451K5B□ (Also used with R88M-K1K530□)
R88M-K1K030□	R88G-HPG32A052K0B□ (Also used with R88M-K2K030□)	R88G-HPG32A112K0B□ (Also used with R88M-K2K030□)	R88G-HPG32A211K5B□ (Also used with R88M-K1K5030□)	R88G-HPG50A332K0B□ (Also used with R88M-K2K030□)	R88G-HPG50A451K5B□ (Also used with R88M-K1K530□)
R88M-K1K530□	R88G-HPG32A052K0B□ (Also used with R88M-K2K030□)	R88G-HPG32A112K0B□ (Also used with R88M-K2K030□)	R88G-HPG32A211K5B□	R88G-HPG50A332K0B□ (Also used with R88M-K2K030□)	R88G-HPG50A451K5B□

● **2,000-r/min servomotors**

Motor model	1/5	1/11	1/21 (1/20 for flange size No.65)	1/33 (1/25 for flange size No.65)	1/45
R88M-K40020□ (Only 400 V)	R88G-HPG32A052K0B□ (Also used with R88M-K2K030□)	R88G-HPG32A112K0B□ (Also used with R88M-K2K030□)	R88G-HPG32A211K5B□ (Also used with R88M-K1K5030□)	R88G-HPG32A33750FB□ (Also used with R88M-K60020□)	R88G-HPG32A45400SB□
R88M-K60020□ (Only 400 V)	R88G-HPG32A052K0B□ (Also used with R88M-K2K030□)	R88G-HPG32A112K0B□ (Also used with R88M-K2K030□)	R88G-HPG32A211K5B□ (Also used with R88M-K1K5030□)	R88G-HPG32A33750FB□	R88G-HPG50A451K5B□ (Also used with R88M-K1K530□)
R88M-K1K020□	R88G-HPG32A053K0B□ (Also used with R88M-K3K030□)	R88G-HPG32A112K0SB□ (Also used with R88M-K2K020□)	R88G-HPG32A211K0SB□	R88G-HPG50A332K0SB□ (Also used with R88M-K2K020□)	R88G-HPG50A451K0SB□
R88M-K1K520□	R88G-HPG32A053K0B□ (Also used with R88M-K3K030□)	R88G-HPG32A112K0SB□ (Also used with R88M-K2K020□)	R88G-HPG50A213K0B□ (Also used with R88M-K3K030□)	R88G-HPG50A332K0SB□ (Also used with R88M-K2K020□)	-

● **1,000-r/min servomotors**

Motor model	1/5	1/11	1/21 (1/20 for flange size No.65)	1/33 (1/25 for flange size No.65)
R88M-K90010□	R88G-HPG32A053K0B□ (Also used with R88M-K5K020□)	R88G-HPG32A112K0SB□ (Also used with R88M-K2K020□)	R88G-HPG50A213K0B□ (Also used with R88M-K3K030□)	R88G-HPG50A332K0SB□ (Also used with R88M-K2K020□)

## Cable Combinations

### ● EtherCAT Communications

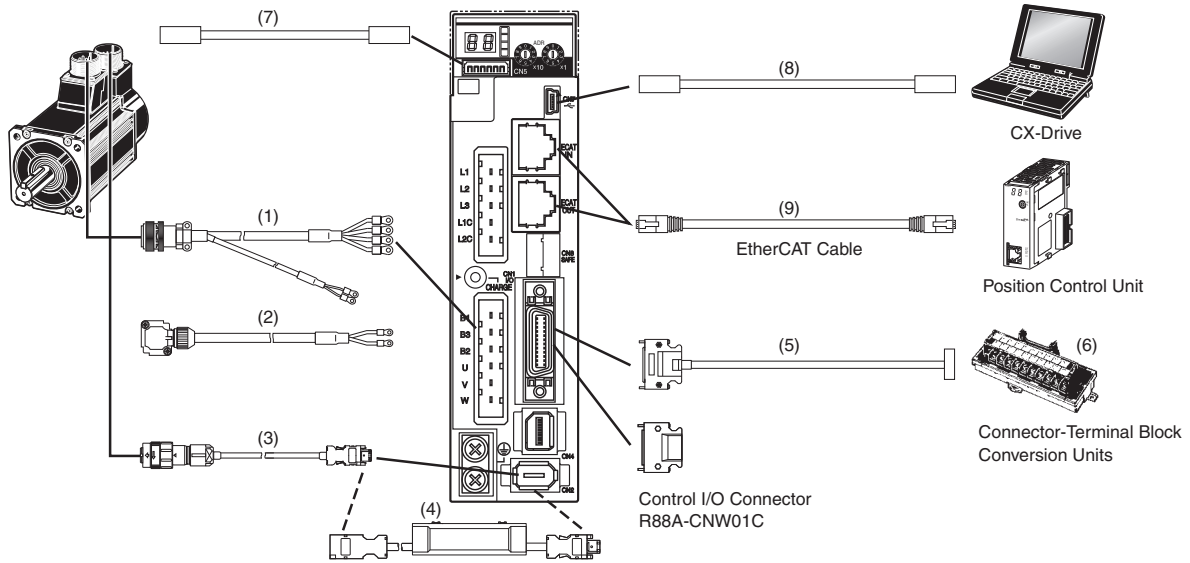

### Servomotor Power Cables (For CNB)

Symbol	Name	Connected to	Model	Description	
(1)	Standard Cables Without Brakes	[100 V] [200 V] Cylindrical Servomotors, 3,000 r/min, 50 to 750 W	R88A-CAKA□□□S The empty boxes in the model number are for the cable length. The cable can be 3, 5, 10, 15, 20, 30, 40, or 50 m long.	 [Servomotor Connector] Angle plug: JN8FT04SJ1 (Japan Aviation Electronics Industry, Ltd.) Contact pins: ST-TMH-S-C1B-3500-A534G (Japan Aviation Electronics Industry, Ltd.)	
		[200 V] Cylindrical Servomotors, 3,000 r/min, 1 to 1.5 kW Cylindrical Servomotors, 2,000 r/min, 1 to 1.5 kW Cylindrical Servomotors, 1,000 r/min, 900 W	R88A-CAGB□□□S The empty boxes in the model number are for the cable length. The cable can be 3, 5, 10, 15, 20, 30, 40, or 50 m long.	 [Servomotor Connector] Straight plug: N/MS3106B20-4S (Japan Aviation Electronics Industry, Ltd.) Cable clamp: N/MS3057-12A (Japan Aviation Electronics Industry, Ltd.)	
		[400 V] Cylindrical Servomotors, 3,000 r/min, 750 W to 1.5 kW Cylindrical Servomotors, 2,000 r/min, 400 W to 1.5 kW Cylindrical Servomotors, 1,000 r/min, 900 W			
	Standard Cables With Brakes	Standard Servomotor Power Cables for Servomotors with Brakes	<b>Note:</b> There are separate connectors for power and brakes for 100 V and 200 V 3,000-r/min motors of 50 to 750 W. Therefore, when a motor with a brake is used, it will require both a power cable for a motor without a brake and a brake cable.		
			[200 V] Cylindrical Servomotors, 3,000 r/min, 1 to 1.5 kW Cylindrical Servomotors, 2,000 r/min, 1 to 1.5 kW Cylindrical Servomotors, 1,000 r/min, 900 W	R88A-CAGB□□□B The empty boxes in the model number are for the cable length. The cable can be 3, 5, 10, 15, 20, 30, 40, or 50 m long.	 [Servomotor Connector] Straight plug: N/MS3106B20-18S (Japan Aviation Electronics Industry, Ltd.) Cable clamp: N/MS3057-12A (Japan Aviation Electronics Industry, Ltd.)
			[400 V] Cylindrical Servomotors, 3,000 r/min, 1 to 1.5 kW Cylindrical Servomotors, 2,000 r/min, 400 W to 1.5 kW Cylindrical Servomotors, 1,000 r/min, 900 W	R88A-CAKF□□□B The empty boxes in the model number are for the cable length. The cable can be 3, 5, 10, 15, 20, 30, 40, or 50 m long.	 [Servomotor Connector] Straight plug: N/MS3106B24-11S (Japan Aviation Electronics Industry, Ltd.) Cable clamp: N/MS3057-16A (Japan Aviation Electronics Industry, Ltd.)

**Note:** Insert the cable length into the boxes in the model number of cables. (3 m: 003, 5 m: 005, 10 m: 010)

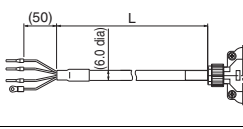
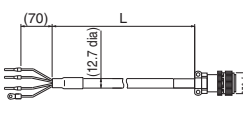
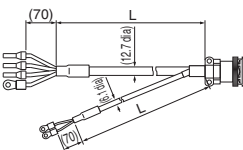
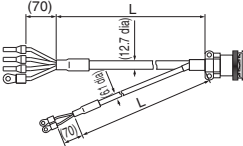

# AC Servomotor/Drive OMNUC G5-series

Symbol	Name	Connected to	Model	Description
(1)	Robot Cables Without Brakes	[100 V] [200 V] Cylindrical Servomotors, 3,000 r/min, 50 to 750 W	R88A-CAKA□□□SR The empty boxes in the model number are for the cable length. The cable can be 3, 5, 10, 15, 20, 30, 40, or 50 m long.	 [50] (16.1 dia) L [Servomotor Connector] Angle plug: JN8FT04SJ1 (Japan Aviation Electronics Industry, Ltd.) Connector pins: ST-TMH-S-C1B-3500-A534G (Japan Aviation Electronics Industry, Ltd.)
		[200 V] Cylindrical Servomotors, 3,000 r/min, 1 to 1.5 kW Cylindrical Servomotors, 2,000 r/min, 1 to 1.5 kW Cylindrical Servomotors, 1,000 r/min, 900 W	R88A-CAGB□□□SR The empty boxes in the model number are for the cable length. The cable can be 3, 5, 10, 15, 20, 30, 40, or 50 m long.	 [70] (12.7 dia) L [Servomotor Connector] Straight plug: N/MS3106B20-4S (Japan Aviation Electronics Industry, Ltd.) Cable clamp: N/MS3057-12A (Japan Aviation Electronics Industry, Ltd.)
		[400 V] Cylindrical Servomotors, 3,000 r/min, 750 W to 1.5 kW Cylindrical Servomotors, 2,000 r/min, 400 W to 1.5 kW Cylindrical Servomotors, 1,000 r/min, 900 W		
	Robot Cables With Brakes	<b>Note:</b> There are separate connectors for power and brakes for 100 V and 200 V 3,000-r/min motors of 50 to 750 W. Therefore, when a motor with a brake is used, it will require both a power cable for a motor with a brake and a brake cable.		
		[200 V] Cylindrical Servomotors, 3,000 r/min, 1 to 1.5 kW Cylindrical Servomotors, 2,000 r/min, 1 to 1.5 kW Cylindrical Servomotors, 1,000 r/min, 900 W	R88A-CAGB□□□BR The empty boxes in the model number are for the cable length. The cable can be 3, 5, 10, 15, 20, 30, 40, or 50 m long.	 [70] (12.7 dia) L [Servomotor Connector] Straight plug: N/MS3106B20-18S (Japan Aviation Electronics Industry, Ltd.) Cable clamp: N/MS3057-12A (Japan Aviation Electronics Industry, Ltd.)
	[400 V] Cylindrical Servomotors, 3,000 r/min, 1 to 1.5 kW Cylindrical Servomotors, 2,000 r/min, 400 W to 1.5 kW Cylindrical Servomotors, 1,000 r/min, 900 W	R88A-CAKF□□□BR The empty boxes in the model number are for the cable length. The cable can be 3, 5, 10, 15, 20, 30, 40, or 50 m long.	 [70] (12.7 dia) L [Servomotor Connector] Straight plug: N/MS3106B24-11S (Japan Aviation Electronics Industry, Ltd.) Cable clamp: N/MS3057-16A (Japan Aviation Electronics Industry, Ltd.)	

**Note:** Insert the cable length into the boxes in the model number of cables. (3 m: 003, 5 m: 005, 10 m: 010)

## Brake Cables

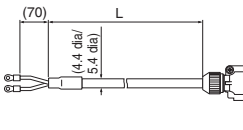
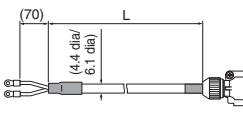
Symbol	Name	Connected to	Model	Description
(2)	Standard Cables Brake Cables (Standard Cables)	[100 V] [200 V] Cylindrical Servomotors, 3,000 r/min, 50 to 750 W	R88A-CAKA□□□B The empty boxes in the model number are for the cable length. The cable can be 3, 5, 10, 15, 20, 30, 40, or 50 m long. (3 to 20 m: 4.4 dia, 30 to 50 m: 5.4 dia)	 [70] (4.4 dia/5.4 dia) L [Servomotor Connector] Angle plug: JN4FT02SJ1-R (Japan Aviation Electronics Industry, Ltd.) Connector pins: ST-TMH-S-C1B-3500-(A534G) (Japan Aviation Electronics Industry, Ltd.)
	Robot Cables Brake Cables (Robot Cables)	[100 V] [200 V] Cylindrical Servomotors, 3,000 r/min, 50 to 750 W	R88A-CAKA□□□BR The empty boxes in the model number are for the cable length. The cable can be 3, 5, 10, 15, 20, 30, 40, or 50 m long. (3 to 20 m: 4.4 dia, 30 to 50 m: 6.1 dia)	 [70] (4.4 dia/6.1 dia) L [Servomotor Connector] Angle plug: JN4FT02SJ1-R (Japan Aviation Electronics Industry, Ltd.) Connector pins: ST-TMH-S-C1B-3500-(A534G) (Japan Aviation Electronics Industry, Ltd.)

**Note:** Insert the cable length into the boxes in the model number of cables. (3 m: 003, 5 m: 005, 10 m: 010)

## Encoder Cables (for CN2)

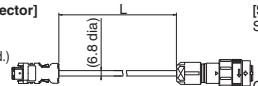
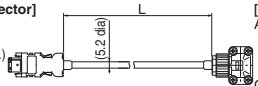
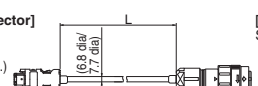
Symbol	Name	Connected to	Model	Description
(3)	Standard Encoder Cables with Connectors	Cylindrical Servomotors, 3,000 r/min, 50 to 750 W (Absolute encoder/ Incremental encoder)	R88A-CRKA□□□C The empty boxes in the model number are for the cable length. The cable can be 3, 5, 10, 15, 20, 30, 40, or 50 m long. (3 to 20 m: 5.2 dia, 30 to 50 m: 6.8 dia)	<p>[Servo Drive Connector] Connector: 55100-0670 (Molex Japan Co., Ltd.)</p>  <p>[Servomotor Connector] Angle clamp: JN6FR07SM1 (Japan Aviation Electronics Industry, Ltd.) Connector pins: LY10-C1-A1-10000 (Japan Aviation Electronics Industry, Ltd.)</p>
		Cylindrical Servomotors, 3,000 r/min, For 1 kW or higher (200 V) For 750 W or higher (400 V) Cylindrical Servomotors, 2,000 r/min, Cylindrical Servomotors, 1,000 r/min, (Absolute encoder/ Incremental encoder)	R88A-CRKC□□□IN The empty boxes in the model number are for the cable length. The cable can be 3, 5, 10, 15, 20, 30, 40, or 50 m long.	<p>[Servo Drive Connector] Connector: 55100-0670 (Molex Japan Co., Ltd.)</p>  <p>[Servomotor Connector] Straight plug: JN2DS10SL2-R (Japan Aviation Electronics Industry, Ltd.) Contact: JN1-22-20S-10000 (Japan Aviation Electronics Industry, Ltd.)</p>
	Robot Encoder Cables with Connectors	Cylindrical Servomotors, 3,000 r/min, 50 to 750 W (Absolute encoder/ Incremental encoder)	R88A-CRKA□□□CR The empty boxes in the model number are for the cable length. The cable can be 3, 5, 10, 15, 20, 30, 40, or 50 m long. (3 to 20 m: 5.2 dia, 30 to 50 m: 6.8 dia)	<p>[Servo Drive Connector] Connector: 55100-0670 (Molex Japan Co., Ltd.)</p>  <p>[Servomotor Connector] Angle clamp: JN6FR07SM1 (Japan Aviation Electronics Industry, Ltd.) Connector pins: LY10-C1-A1-10000 (Japan Aviation Electronics Industry, Ltd.)</p>
		Cylindrical Servomotors, 3,000 r/min, For 1 kW or higher (200 V) For 750 W or higher (400 V) Cylindrical Servomotors, 2,000 r/min, Cylindrical Servomotors, 1,000 r/min, (Absolute encoder/ Incremental encoder)	R88A-CRKC□□□NR The empty boxes in the model number are for the cable length. The cable can be 3, 5, 10, 15, 20, 30, 40, or 50 m long. (3 to 20 m: 6.8 dia, 30 to 50 m: 7.7 dia)	<p>[Servo Drive Connector] Connector: 55100-0670 (Molex Japan Co., Ltd.)</p>  <p>[Servomotor Connector] Straight plug: JN2DS10SL2-R (Japan Aviation Electronics Industry, Ltd.) Cable clamp: JN1-22-22S-10000 (Japan Aviation Electronics Industry, Ltd.)</p>

**Note:** Insert the cable length into the boxes in the model number of cables. (3 m: 003, 5 m: 005, 10 m: 010)

## Absolute Encoder Backup Battery and Absolute Encoder Battery Cable

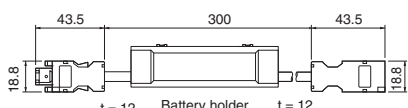
Symbol	Name	Specifications	Model	Description
(4)	Absolute Encoder Battery Cable	Battery not included	0.3 m R88A-CRGD0R3C	
		One R88A-BAT01G Battery included.	0.3 m R88A-CRGD0R3C-BS	
	Absolute Encoder Backup Battery	-	R88A-BAT01G	-

## Control Cables (for CN1)

Symbol	Name	Connected to	Model	
(5)	For Connector Terminal Block	Connector Terminal Block Cables	Cable for EtherCAT Communications type	
(6)		Connector-Terminal Block Conversion Units	Cable for EtherCAT Communications type	M3 screws XW2B-20G4
				M3.5 screws XW2B-20G5
		M3 screws XW2D-20G6		

**Note:** Insert the cable length into the boxes in the model number of cables. (1m: 100, 2m: 200)

## Monitor Connector (for CN5)

Symbol	Name	Lengths	Model
(7)	Analog Monitor Cable	1 m	R88A-CMK001S

## Communications Connector (for CN7)

Symbol	Name	Description
(8)	USB communications cable	General purpose USB cable can be used

**Note:** Use a commercially available USB cable that is shield, equipped with a ferrite core for noise immunity, and Supporting for USB2.0. The Mini B type USB cable can be used.

# AC Servomotor/Drive OMNUC G5-series

## Connectors

Connectors	Name	Model
CN1	Control I/O Connector (for EtherCAT Communications type)	R88A-CNW01C
CN2	Encoder Connector	R88A-CNW01R
CN4	External scale connector	R88A-CNK41L
CN8	Safety connector	R88A-CNK81S

## Servomotor Connector

Connectors	Name	Connected to	Model
-	Motor connector for encoder cable	[100V/200V] 3,000 r/min (50 to 750 W)	R88A-CNK02R
		[100V/200V] 3,000 r/min (1.0 to 1.5 kW) 2,000 r/min, 1,000 r/min [400V] 3,000 r/min, 2,000 r/min and 1,000 r/min	R88A-CNK04R
-	Power cable connector	[100 V/200 V] 750 W max.	R88A-CNK11A
-	Brake cable connector	[100 V/200 V] 750 W max.	R88A-CNK11B

## EtherCAT Communication Cable

Symbol	Name	Description
(9)	Ethernet cable	EtherCAT Communication Cables <ul style="list-style-type: none"> <li>Use a category 5 or higher cable with double, aluminum tape and braided shielding.</li> </ul> Connector (Modular Plug) Specifications <ul style="list-style-type: none"> <li>Use a category 5 or higher, shielded connector.</li> </ul>

## About Manuals

Manual	Man. No.	Model	Application	Description
OMNUC G5-SERIES EtherCAT Communications AC SERVO MOTOR AND SERVO DRIVE USER'S MANUAL	I573	R88M-K□ R88D-KN□-ECT-R	Information on OMNUC G5 Series	Describes the setting and application procedures for G5 series.
CX-Drive Operation Manual	W453	CXONE-AL□□C-V□/ -AL□□D-V□ WS02-DRVC1	Support Software for Inverter and Servo CX-Drive setting procedure	Describes operating procedures for the CX-Drive.

## Read and Understand this Catalog

Please read and understand this catalog before purchasing the product. Please consult your OMRON representative if you have any questions or comments.

## Warranty and Limitations of Liability

### WARRANTY

OMRON's exclusive warranty is that the products are free from defects in materials and workmanship for a period of one year (or other period if specified) from date of sale by OMRON.

OMRON MAKES NO WARRANTY OR REPRESENTATION, EXPRESS OR IMPLIED, REGARDING NON-INFRINGEMENT, MERCHANTABILITY, OR FITNESS FOR PARTICULAR PURPOSE OF THE PRODUCTS. ANY BUYER OR USER ACKNOWLEDGES THAT THE BUYER OR USER ALONE HAS DETERMINED THAT THE PRODUCTS WILL SUITABLY MEET THE REQUIREMENTS OF THEIR INTENDED USE. OMRON DISCLAIMS ALL OTHER WARRANTIES, EXPRESS OR IMPLIED.

### LIMITATIONS OF LIABILITY

OMRON SHALL NOT BE RESPONSIBLE FOR SPECIAL, INDIRECT, OR CONSEQUENTIAL DAMAGES, LOSS OF PROFITS OR COMMERCIAL LOSS IN ANY WAY CONNECTED WITH THE PRODUCTS, WHETHER SUCH CLAIM IS BASED ON CONTRACT, WARRANTY, NEGLIGENCE, OR STRICT LIABILITY.

In no event shall the responsibility of OMRON for any act exceed the individual price of the product on which liability is asserted.

IN NO EVENT SHALL OMRON BE RESPONSIBLE FOR WARRANTY, REPAIR, OR OTHER CLAIMS REGARDING THE PRODUCTS UNLESS OMRON'S ANALYSIS CONFIRMS THAT THE PRODUCTS WERE PROPERLY HANDLED, STORED, INSTALLED, AND MAINTAINED AND NOT SUBJECT TO CONTAMINATION, ABUSE, MISUSE, OR INAPPROPRIATE MODIFICATION OR REPAIR.

## Application Considerations

### SUITABILITY FOR USE

OMRON shall not be responsible for conformity with any standards, codes, or regulations that apply to the combination of the product in the customer's application or use of the product.

Take all necessary steps to determine the suitability of the product for the systems, machines, and equipment with which it will be used.

Know and observe all prohibitions of use applicable to this product.

NEVER USE THE PRODUCT FOR AN APPLICATION INVOLVING SERIOUS RISK TO LIFE OR PROPERTY WITHOUT ENSURING THAT THE SYSTEM AS A WHOLE HAS BEEN DESIGNED TO ADDRESS THE RISKS, AND THAT THE OMRON PRODUCT IS PROPERLY RATED AND INSTALLED FOR THE INTENDED USE WITHIN THE OVERALL EQUIPMENT OR SYSTEM.

### PROGRAMMABLE PRODUCTS

OMRON shall not be responsible for the user's programming of a programmable product, or any consequence thereof.

## Disclaimers

### CHANGE IN SPECIFICATIONS

Product specifications and accessories may be changed at any time based on improvements and other reasons. Consult with your OMRON representative at any time to confirm actual specifications of purchased product.

### DIMENSIONS AND WEIGHTS

Dimensions and weights are nominal and are not to be used for manufacturing purposes, even when tolerances are shown.

### PERFORMANCE DATA

Performance data given in this catalog is provided as a guide for the user in determining suitability and does not constitute a warranty. It may represent the result of OMRON's test conditions, and the users must correlate it to actual application requirements. Actual performance is subject to the OMRON Warranty and Limitations of Liability.

**OMRON Corporation Industrial Automation Company**

Tokyo, JAPAN

Contact: [www.ia.omron.com](http://www.ia.omron.com)

**Regional Headquarters**

**OMRON EUROPE B.V.**

Wegalaan 67-69-2132 JD Hoofddorp  
The Netherlands

Tel: (31)2356-81-300/Fax: (31)2356-81-388

**OMRON ELECTRONICS LLC**

One Commerce Drive Schaumburg,  
IL 60173-5302 U.S.A.

Tel: (1) 847-843-7900/Fax: (1) 847-843-7787

**OMRON ASIA PACIFIC PTE. LTD.**

No. 438A Alexandra Road # 05-05/08 (Lobby 2),  
Alexandra Technopark,  
Singapore 119967

Tel: (65) 6835-3011/Fax: (65) 6835-2711

**OMRON (CHINA) CO., LTD.**

Room 2211, Bank of China Tower,  
200 Yin Cheng Zhong Road,  
PuDong New Area, Shanghai, 200120, China  
Tel: (86) 21-5037-2222/Fax: (86) 21-5037-2200

**Authorized Distributor:**

© OMRON Corporation 2010 All Rights Reserved.  
In the interest of product improvement,  
specifications are subject to change without notice.

**Cat. No. I818-E1-01**

Printed in Japan  
0510 (0510) (W)