

阅读申明

- 1.本站收集的数据手册和产品资料都来自互联网，版权归原作者所有。如读者和版权方有任何异议请及时告之，我们将妥善解决。
- 2.本站提供的中文数据手册是英文数据手册的中文翻译，其目的是协助用户阅读，该译文无法自动跟随原稿更新，同时也可能存在翻译上的不当。建议读者以英文原稿为参考以便获得更精准的信息。
- 3.本站提供的产品资料，来自厂商的技术支持或者使用者的心得体会等，其内容可能存在描述上的差异，建议读者做出适当判断。
- 4.如需与我们联系，请发邮件到marketing@iczoom.com，主题请标有“数据手册”字样。

Read Statement

1. The datasheets and other product information on the site are all from network reference or other public materials, and the copyright belongs to the original author and original published source. If readers and copyright owners have any objections, please contact us and we will deal with it in a timely manner.
2. The Chinese datasheets provided on the website is a Chinese translation of the English datasheets. Its purpose is for reader's learning exchange only and do not involve commercial purposes. The translation cannot be automatically updated with the original manuscript, and there may also be improper translations. Readers are advised to use the English manuscript as a reference for more accurate information.
3. All product information provided on the website refer to solutions from manufacturers' technical support or users the contents may have differences in description, and readers are advised to take the original article as the standard.
4. If you have any questions, please contact us at marketing@iczoom.com and mark the subject with "Datasheets" .

Vacuum Fluorescent Display Module

Hardware Specification

Model: GU256X128E-3900B

Specification No: DS-1643-0001-00

Date of Issue: January 23, 2012 (00)

Revision:

Published by
NORITAKE ITRON Corp. / Japan
<http://www.noritake-itron.jp>

This specification is subject to change without prior notice.

This product complies with RoHS Directive 2011/65/EU

Contents

1 General Description 2

1.1 Scope..... 2

1.2 Construction..... 2

1.3 Outline..... 2

1.4 Block Diagram 2

2 General-purpose I/O port..... 3

3 Electrical Specifications 3

3.1 Absolute Maximum Ratings..... 3

3.2 Electrical Ratings 3

3.3 Electrical Characteristics..... 4

4 Environmental Specifications..... 5

5 Optical Specifications..... 5

6 Physical Specifications 5

7 Applicable Specifications 5

8 Interface..... 5

8.1 Interface timing 5

8.1.1 Parallel interface timing 1 (Not applicable for bit image data transfer in DMA mode) 5

8.1.2 Parallel interface timing 2 (Applicable for bit image data transfer in DMA mode)..... 6

8.1.3 RS-232 Asynchronous serial interface timing..... 6

9 Setup 7

9.1 DIP-Switch (SW1) 7

10 Connectors 7

10.1 Parallel interface connector (CN6) 7

10.2 RS-232 interface connector (CN7)..... 7

10.3 General-purpose I/O port connector (CN4)..... 7

10.4 Power connector (CN1)..... 7

10.5 Connector position 8

11 Physical Dimensions 9

Notice for the Cautious Handling of VFD Modules 10

Revision history 11

1 General Description

1.1 Scope

This specification covers the hardware aspects of the GU256X128E-3900B vacuum fluorescent graphic display module.

1.2 Construction

The module consists of a 256 × 128 dot graphic BD-VFD, refresh RAM, character generator, DC/DC converter, display controller, and all necessary control logic. The module can simultaneously display graphic patterns and characters on the screen.

1.3 Outline

Power supply: + 5 V_{DC} + 12V_{DC}
 Interface: Parallel interface (CMOS)
 Serial interface (Asynchronous, RS-232 -level)
 I/O port: 12 bits General-purpose I/O port
 Protocol: Direct mode
 Packet mode
 Function: Character display
 Graphic display
 Control command
 Display action command
 Draw command
 Window function
 General-purpose I/O port control
 Macro, Program Macro function
 Character and Bit Image download function
 Memory SW
 Display power auto-OFF function
 General-purpose data storage

For full details, refer to:

DS-1600-0008-XX: GU-3900B series “General Function” Software Specification.

DS-1600-0006-XX: “Program Macro” software specification.

1.4 Block Diagram

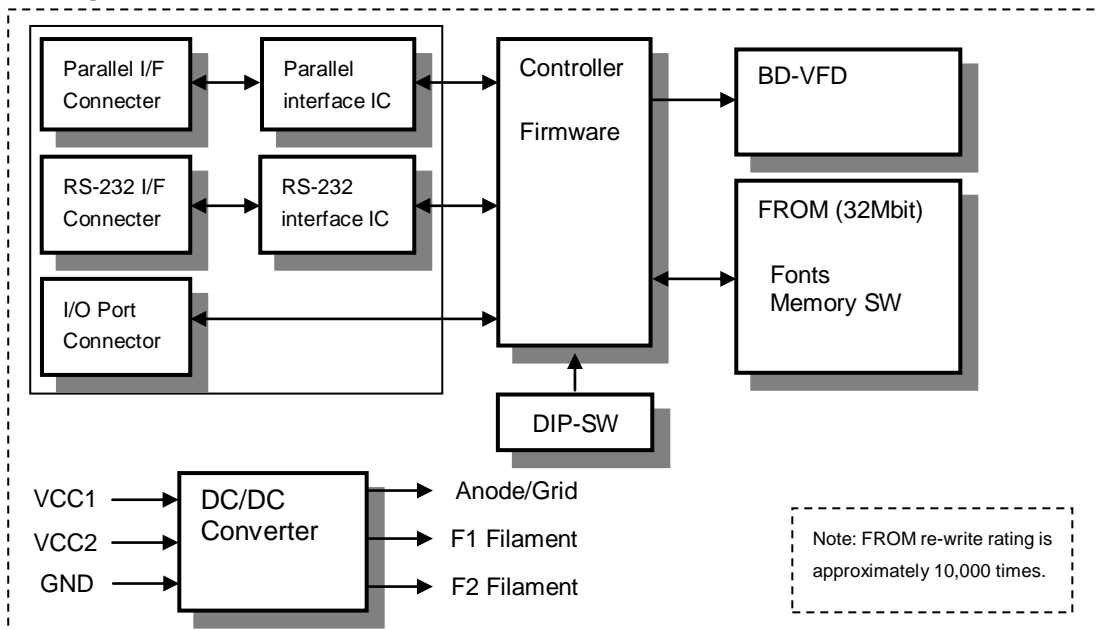

2 General-purpose I/O port

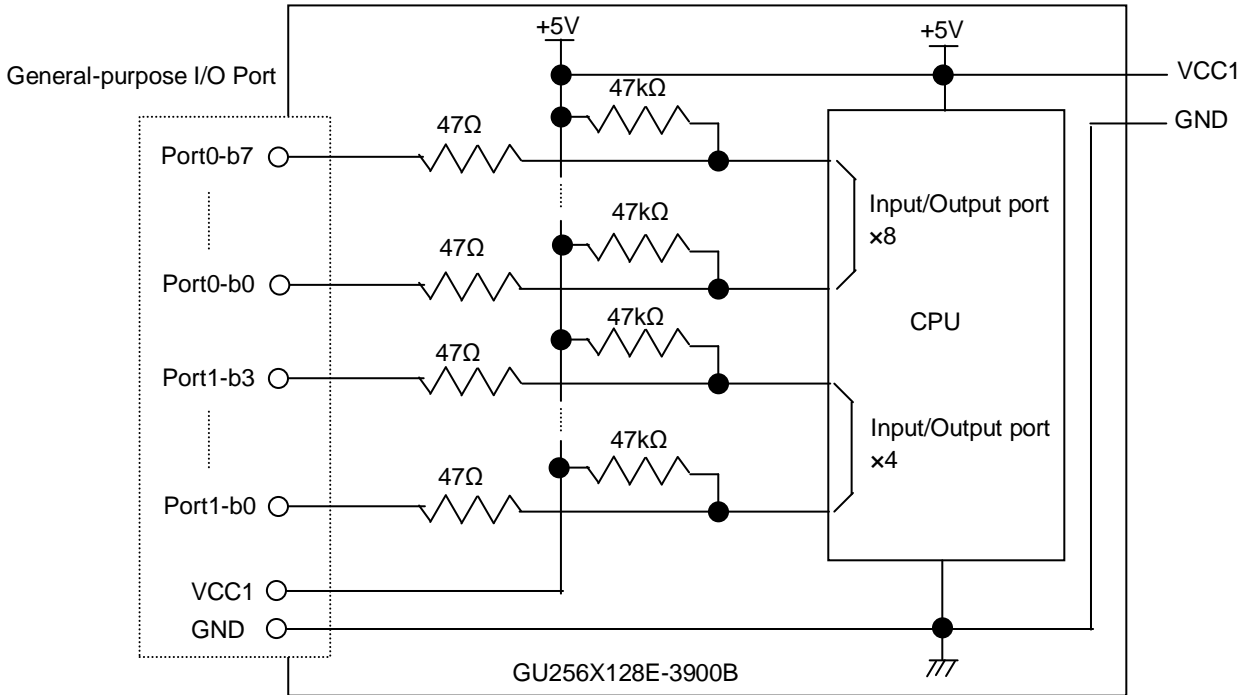

Refer to 3.3 Electrical Characteristics, “General-purpose I/O port supply Voltage”.

For controlling, refer to “General Function” Software Specification, “I/O Port Input / Output setting”, “I/O Port Output”, and “I/O Port Input”.

3 Electrical Specifications

3.1 Absolute Maximum Ratings

Power Supply Voltage

Parameter	Symbol	Min.	Typ.	Max.	Unit	Note
Power Supply Voltage	VCC1	-0.3	-	+6.0	VDC	-
	VCC2	-0.3	-	+13.8	VDC	-

Logic Supply Voltage

Parameter	Symbol	Min.	Typ.	Max.	Unit	Note	
Parallel I/F	D0 – D7, /WR	VpIN	-0.3	-	Vcc+0.3	VDC	-
RS-232 I/F	RXD, DSR	VsIN	-25	-	+25	VDC	-

I/O port supply Voltage

Parameter	Symbol	Min.	Typ.	Max.	Unit	Note	
I/O port	Port 0, Port 1	ViIN	-0.3	-	Vcc+0.3	VDC	-

3.2 Electrical Ratings

Parameter	Symbol	Min.	Typ.	Max.	Unit	Note
Power Supply Voltage	VCC1	4.75	5.0	5.25	VDC	-
	VCC2	11.4	12.0	12.6	VDC	-

All driving voltage for the VFD is converted from the on-board DC/DC converter.

3.3 Electrical Characteristics

Logic input/output condition

Measuring Conditions: Ambient temperature = 25 °C, VCC1=5.0VDC

Parameter		Symbol	Min.	Typ.	Max.	Unit	Condition	Note
Parallel I/F	Logic input current D0 – D7, /WR	IpiH	-	-	1.0	uADC	-	-
		IpiL	-	-	-200	uADC	-	-
	Logic input voltage D0 – D7, /WR	VpiH	0.8VCC		VCC	VDC	-	-
		VpiL	0		0.2VCC	VDC	-	-
	Logic output voltage RDY	VpOH	3.5		VCC	VDC	IOH= -10uA	(1)
VpOL		0		0.6	VDC	IOL=4mA		
RS-232 I/F	Logic input voltage RXD, DSR	VsiH	3	-	15	VDC	-	-
		VsiL	-15	-	-3	VDC	-	-
	Logic output voltage TXD, DTR	VsoH	5	-	-	VDC	RL=3kΩ	-
		VsoL	-	-	-5	VDC		-
	Logic input Impedance RXD, DSR	RsiN	3	-	7	kΩ		-

(1) "RDY" terminal is open collector (pulled-up by 47kΩ)

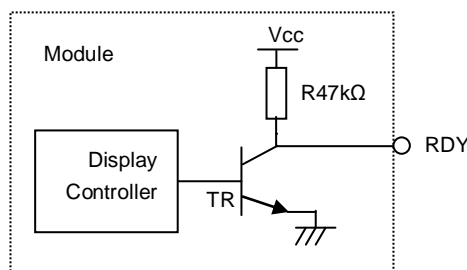

General-purpose I/O port supply Voltage

Measuring Conditions: Ambient temperature = 25 °C, VCC1=5.0VDC

Parameter		Symbol	Min.	Typ.	Max.	Unit	Condition	Note
General-purpose I/O port	Logic input current Port 0, 1	IiIH	-	-	1.0	uADC	-	-
		IiIL	-	-	-200	uADC	-	-
	Logic input voltage Port 0, 1	ViiH	4.1	-	VCC	VDC	-	-
		ViiL	0	-	0.8	VDC	-	-
	Logic output voltage Port 0, 1	ViOH	VCC-0.6	-	-	VDC	IOH=-200uA	-
		ViOL	-	-	0.5	VDC	IOL=1.6mA	-

General-purpose I/O port output permissible current

Measuring Conditions: Ambient temperature = 25 °C, VCC1=5.0VDC

Parameter		Symbol	Min.	Typ.	Max.	Unit	Condition	Note
General-purpose I/O port	Output permissible current Port 0, 1 (Single port)	IiOH	-	-	1.5	mADC	-	-
		IiOL	-	-	3	mADC	-	-
	Output permissible current Port 0, 1 (Sum of all ports)	IiOH	-	-	8	mADC	-	-
		IiOL	-	-	30	mADC	-	-

Output current should not be exceeded from the value of above table.

In case of driving the LED or some other device directly, please be sure to insert current limiter into an output line.

Power Supply condition

Measuring Conditions: Ambient temperature = 25 °C, VCC1=5.0VDC, VCC2=12.0VDC

Parameter	Symbol	Min.	Typ.	Max.	Unit	Condition
Power Supply Current 1	ICC1	-	80	120	mADC	All dots ON
Power Supply Current 2	ICC2-1	-	0.75	1.05	ADC	All dots ON
	ICC2-2	-	0.55	0.75	ADC	All dots OFF
Power Supply Current 3	ICC2-3	-	0.7	1.4	mADC	Display power OFF
Power Consumption		-	9.4	13.2	W	All dots ON

Note:

The rise time of supply voltage should not exceed 100ms.

Inrush current at power-on may exceed twice normal current.

Display power OFF: Refer to "General Function" Software Specification, "Display power ON/OFF/auto-OFF" command.

4 Environmental Specifications

- Operating temperature: -40 to +70 °C
- Storage temperature: -40 to +85 °C
- Storage humidity: 20 to 80 % R.H (Non Condensing)
- Vibration (non-operating): 10-55-10Hz, all amplitude 1mm, 30 minutes, X-Y-Z
- Shock (non-operating): 392m/s² (40G) 9ms X-Y-Z, 3 times each direction

5 Optical Specifications

- Luminance: 350cd/m² Min. (500cd/m² Typ.)
- Color of illumination: Green (Blue Green)

6 Physical Specifications

- Number of dots: 32,768 (256 × 128)
- Display area: 140.65mm x 70.25mm(X x Y)
- Dot size: 0.4mm × 0.4mm (X × Y)
- Dot pitch: 0.55mm × 0.55mm (X × Y)
- Weight: Approximately 630g

7 Applicable Specifications

- Applicable VFD Module reliability specification : TT-99-3102
- Applicable VFD Module quality specification : TT-98-3413
- Applicable VFD quality specification : TT-93-3336D

8 Interface

Parallel and RS-232 Serial interfaces are available on this module.

8.1 Interface timing

8.1.1 Parallel interface timing 1 (Not applicable for bit image data transfer in DMA mode)

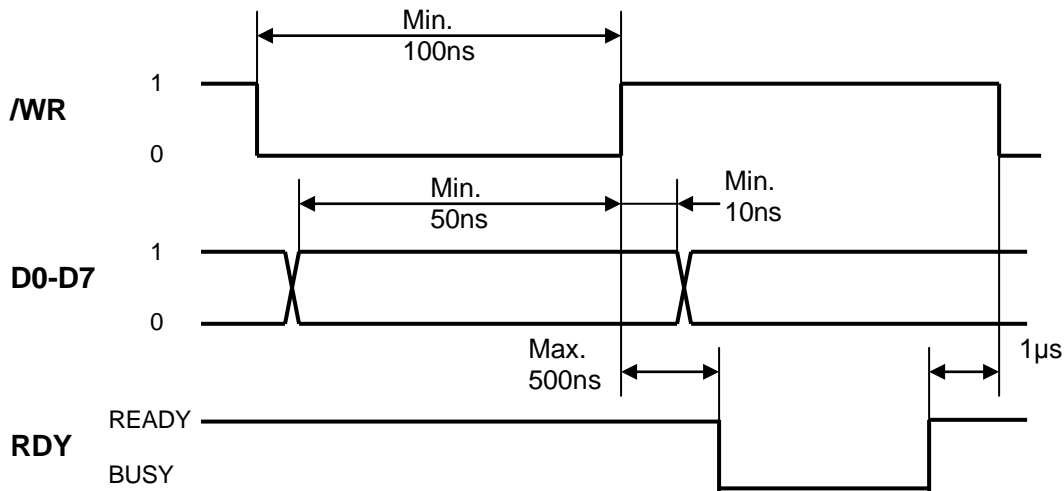

Note: RDY=0 (BUSY) is output after every byte.

Internal receive buffer capacity is 256 bytes. After data is input, RDY signal is immediately set to RDY=0 (BUSY) until the received byte is stored to the receive buffer. If the internal receive buffer is full, RDY signal will remain BUSY until space for 1 byte becomes available. The required time for this varies, depending on the type of commands and rate at which data is input. The RDY signal should always be checked before writing data.

8.1.2 Parallel interface timing 2 (Applicable for bit image data transfer in DMA mode)

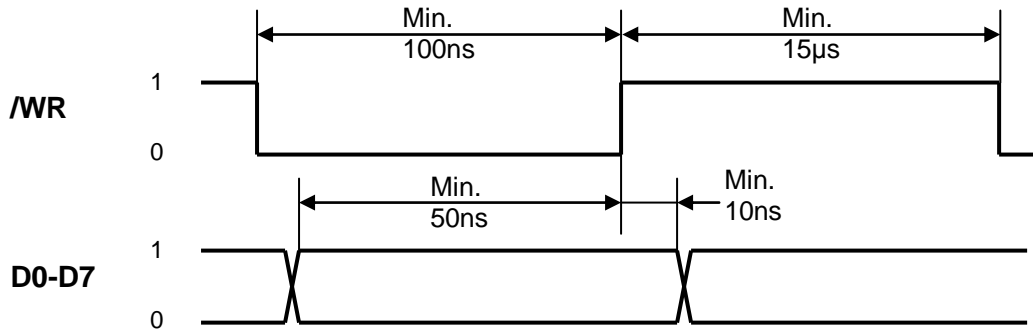

Note: Monitoring RDY signal is not necessary for bit image data transfer in DMA mode.

8.1.3 RS-232 Asynchronous serial interface timing

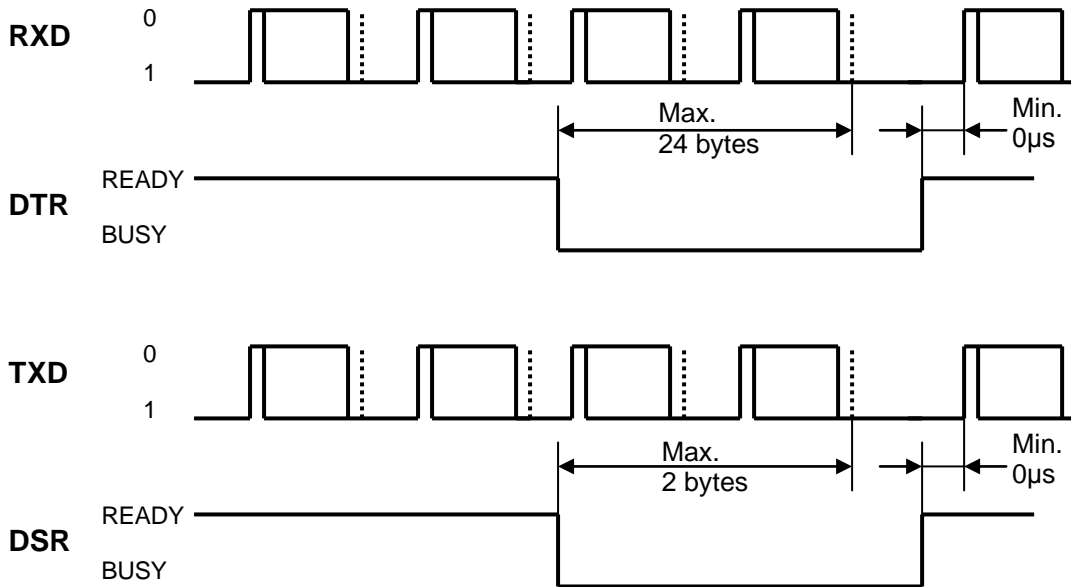

The above timing is RS-232 level. Logical value is the inverse of the above. (VsiH:0, VsiL:1)

Interface:

Baud rate	4800, 9600, 19200, 38400 (default) , 57600, 115200bps (Selected by DIP SW and Memory-SW)
Parity	None (default) , Even, Odd
Format	Start (1 bit) + Data (8 bits) [+ Parity (1 bit)] + Stop (1 bit)
Handshake	DTR, DSR

Buffer Capacity

Receive buffer	256 bytes
Transmit buffer	128 bytes

DTR signal change timing

DTR change	1 (READY) → 0 (BUSY)	0 (BUSY) → 1 (READY)
Receive buffer space	32 bytes or less	64 bytes or more

9 Setup

9.1 DIP-Switch (SW1)

SW No.	Function	Default
1	Display address select (For multi-connection)	Off
2		Off
3		Off
4		Off
5	RS-232 interface setting	Off
6	Command mode select	Off
7	Operating Mode select	Off
8	Protocol select	Off

For DIP-SW setup details, refer to “General Function” Software Specification, “Setup”.

10 Connectors

10.1 Parallel interface connector (CN6)

Pin No.	Signal name	Function	Direction	Pin No.	Signal name	Function	Direction
1	D7	Data input	Input	2	D6	Data input	Input
3	D5	Data input	Input	4	D4	Data input	Input
5	D3	Data input	Input	6	D2	Data input	Input
7	D1	Data input	Input	8	D0	Data input	Input
9	GND	Ground	Input	10	WR	Data write	Input
11	GND	Ground	Input	12	RDY	Display READY	Output
13	GND	Ground	Input	14	GND	Ground	Input
15	VCC1	Power supply (5V)	Input	16	VCC1	Power supply (5V)	Input

10.2 RS-232 interface connector (CN5)

Pin No.	Signal name	Function	Direction
1	RXD	Data receive	Input
2	DTR	Display busy	Output
3	DSR	Host busy	Input
4	TXD	Data send	Output
5	TEST *	TEST (Factory use only)	Input
6	VCC1	Power supply (5V)	Input
7	GND	Ground	Input

* Factory use only (leave this pin open)

10.3 General-purpose I/O port connector (CN4)

Pin No.	Signal name	Function	Direction	Pin No.	Signal name	Function	Direction		
1	bit 7	Input/Output Port 0	Input/Output	8	bit 0	Port 0	Input/Output		
2	bit 6			Input/Output Port 1	Input/Output	9	bit 3	Power supply (5V)	Input
3	bit 5					10	bit 2		
4	bit 4					11	bit 1		
5	bit 3					12	bit 0		
6	bit 2			13	VCC1	Ground	Input		
7	bit 1			14	GND	Ground	Input		

10.4 Power connector (CN1)

Pin No.	Signal name	Function	Direction
1	VCC1	Power supply (5V)	Input
2	GND	Ground	Input
3	VCC2	Power supply (12V)	Input
4	VCC2	Power supply (12V)	Input
5	GND	Ground	Input
6	GND	Ground	Input
7	NC	No Connection	-
8	TEST *	TEST (Factory use only)	Input

* Factory use only (leave this pin open)

10.5 Connector position

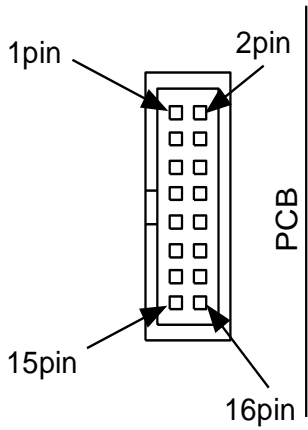

Parallel interface connector
IRISO: IMSA-9032B-16P or equivalent

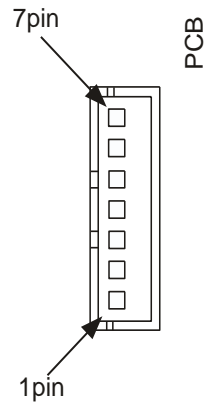

RS-232 interface connector
JST: B7B-XH-A or equivalent

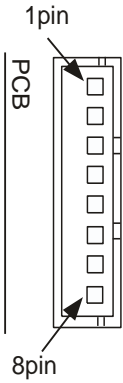

Power connector
JST: B8B-XH-A or equivalent

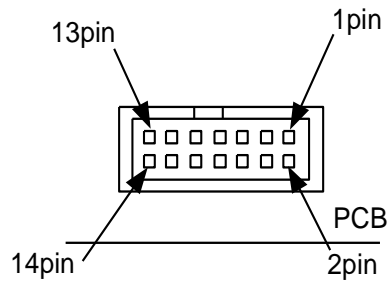

General-purpose I/O port connector
IRISO: IMSA-9032B-14P or equivalent

11 Physical Dimensions

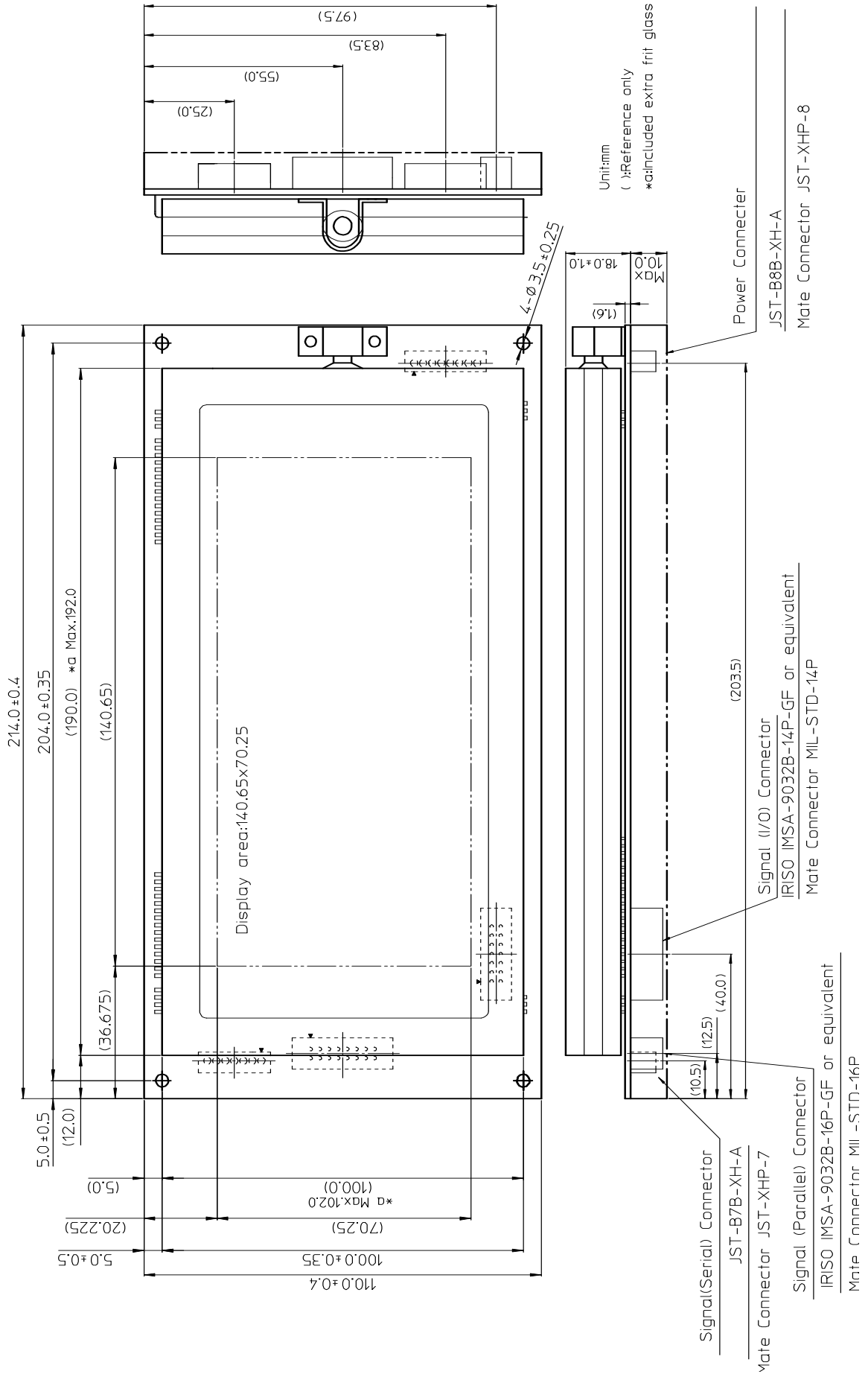

Notice for the Cautious Handling of VFD Modules

Handling and Usage Precautions:

Please carefully follow the appropriate product application notes and operation standards for proper usage, safe handling, and maximum performance.

[VFD tubes are made of glass]

- The edges of the VFD glass envelope are not smooth, so it is necessary to handle carefully to avoid injuries to hands.
- Use caution to avoid breaking the VFD glass envelope, to prevent injury from sharp glass particles.
- The tip of the exhaust pipe is fragile so avoid shock from impact.
- It is recommended to allow sufficient open space surrounding the exhaust pipe to avoid possible damage.
- Please design the PCB for the VFD module within 0.3 mm warping tolerance to avoid any forces that may damage the display due to PCB distortion causing a breakdown of the electrical circuit leading to VFD failure.

[High voltage]

- Avoid touching conductive electrical parts, because the VFD module uses high voltage exceeding 30 – 100 volts.
- Even when electric power is turned off, it may take more than one minute for the electrical current to discharge.

[Cable connection]

- Do not unplug the power and/or data cables of VFD modules during operation, because unrecoverable damage may result.
- Sending input signals to the VFD module when not powered can cause I/O port damage.
- It is recommended to use a 30cm or shorter signal cable to prevent functional failures.

[Electrostatic charge]

- VFD modules need electrostatic-free packaging and protection from electrostatic charges during handling and usage.

[Structure]

- During operation, VFD and VFD modules generate heat. Please consider sufficient heat radiation dissipation using heat sink solutions.
- Preferably, use UL-grade materials or components in conjunction with VFD modules.
- Warp and twist movement causes stress and may break VFDs and VFD modules. Please adhere to allowances within 0.3mm at the point of attachment.

[Power]

- Apply regulated power to the VFD module within specified voltages to protect from failures.
- VFD modules may draw in-rush current exceeding twice the typical current at power-on, so a power supply with sufficient capacity and quick starting of the power regulator is recommended.
- VFD module needs a specified voltage at the point of connection. Please use an adequate power cable to avoid a decrease in voltage. As a safety measure, a fuse or other over-current protection is recommended.

[Operating consideration]

- Illuminating phosphor will decrease in brightness during extended operation. If a fixed pattern illuminates for an extended period (several hours), the phosphor efficiency will decrease compared to the non-operating phosphor, causing non-uniform brightness. Please consider programming the display patterns to use all phosphor segments evenly. Scrolling may be a consideration for a period of time to refresh the phosphor condition and improve even illumination of the pixels.
- A signal cable 30cm or less is recommended to avoid possible disturbances to the signal.

[Storage and operating environment]

- Please use VFD modules under the recommended specified environmental conditions. Salty, sulfuric and dusty environments may damage the VFD module even during storage.

[Disposal]

- VFD uses lead-containing materials (RoHS directive exempts these lead compounds in the glass for electronic devices). When discarding VFDs or VFD modules, please adhere to applicable laws and regulations.

[Other cautions]

- Although the VFD module is designed to be protected from electrical noise, please plan your circuitry to exclude as much noise as possible.
- Do not reconstruct or repair the VFD module without our authorization. We cannot assure the quality or reliability of unauthorized reconstructed VFD modules.

Notice:

- We do not authorize the use of any patents that may be inherent in these specifications.
- Neither whole nor partial copying of these specifications is permitted without our approval. If necessary, please ask for assistance from our sales consultant.
- This product is not designed for military, aerospace, medical or other life-critical applications. If you choose to use this product for these applications, please ask us for prior consultation or we cannot accept responsibility for problems that may occur.

MBBZ-009-S18A

Revision history

Specification number	Date	Revision
DS-1643-0001-00	Jan. 23, 2012	Initial release