

阅读申明

- 1.本站收集的数据手册和产品资料都来自互联网，版权归原作者所有。如读者和版权方有任何异议请及时告之，我们将妥善解决。
- 2.本站提供的中文数据手册是英文数据手册的中文翻译，其目的是协助用户阅读，该译文无法自动跟随原稿更新，同时也可能存在翻译上的不当。建议读者以英文原稿为参考以便获得更精准的信息。
- 3.本站提供的产品资料，来自厂商的技术支持或者使用者的心得体会等，其内容可能存在描述上的差异，建议读者做出适当判断。
- 4.如需与我们联系，请发邮件到marketing@iczoom.com，主题请标有“数据手册”字样。

Read Statement

1. The datasheets and other product information on the site are all from network reference or other public materials, and the copyright belongs to the original author and original published source. If readers and copyright owners have any objections, please contact us and we will deal with it in a timely manner.
2. The Chinese datasheets provided on the website is a Chinese translation of the English datasheets. Its purpose is for reader's learning exchange only and do not involve commercial purposes. The translation cannot be automatically updated with the original manuscript, and there may also be improper translations. Readers are advised to use the English manuscript as a reference for more accurate information.
3. All product information provided on the website refer to solutions from manufacturers' technical support or users the contents may have differences in description, and readers are advised to take the original article as the standard.
4. If you have any questions, please contact us at marketing@iczoom.com and mark the subject with "Datasheets" .

AFBR-2CARxxZ

10G Ethernet SFP+ Active Optical Cable (AOC)



Product Brief



Description

The Avago Technologies' AFBR-2CARxxZ Active Optical Cable (AOC) is part of a family of SFP+ products to serve 10Gb Ethernet (10GbE) applications. The letters "xx" of the part number AFBR-2CARxxZ denote the cable length in meters. The AFBR-2CARxxZ AOC enables 10GbE equipment designs with very high port density based on the electrical and mechanical specification enhancements to the well known SFP specifications developed by the SFF Committee. The specifications are referred to as "SFP+" to represent the enhancements over previous SFP specifications. The SFP+ AOC have a cable length up to 20m. These AOCs can be used as an alternative solution to SFP+ passive and active copper cables, while providing improved signal integrity, longer distances, superior electromagnetic immunity and better bit error rate performance.

Part Numbers

AFBR-2CAR01Z	1 meter SFP+ Active Optical Cable
AFBR-2CAR02Z	2 meter SFP+ Active Optical Cable
AFBR-2CAR03Z	3 meter SFP+ Active Optical Cable
AFBR-2CAR05Z	5 meter SFP+ Active Optical Cable
AFBR-2CAR07Z	7 meter SFP+ Active Optical Cable
AFBR-2CAR10Z	10 meter SFP+ Active Optical Cable
AFBR-2CAR15Z	15 meter SFP+ Active Optical Cable
AFBR-2CAR20Z	20 meter SFP+ Active Optical Cable
AFCT-5016Z	SFP+ Evaluation Board

Features

- Proven High Reliability 850 nm technology: Avago VCSEL transmitter and Avago PIN receiver
- Maximum power dissipation 350 mW per Active Cable end
- Avago SFP+ package design enables equipment EMI performance in high port density applications with margin to Class B limits

Specifications

- Electrical specifications per SFF-8431 Specifications for Enhanced Small Form Factor Pluggable Module SFP+
- 0 to 70 °C case temperature operating range
- Rx_LOS and Tx_DISABLE supported
- Mechanical specifications per SFF Committee SFF 8432 Improved Pluggable Formfactor "IPF"
- Compliant to Restriction on Hazardous Substances (RoHS) per EU and China requirements
- Class 1 eye safe per requirement of EN 60825-1 2007, EN 60825-2 A2 2010
- 1E-15 BER performance

Applications

- 1/10 Gigabit Ethernet (1/10GbE)
- 1/2/4/8G Fibre Channel (1/2/4/8GFC), Fibre Channel
- InfiniBand (QDR/DDR/SDR)
- Data Center Networking
 - Converged Enhanced Ethernet Data Centers
 - Data Center Bridging
- Networked storage systems
- High Performance Computing
- Proprietary Interconnects

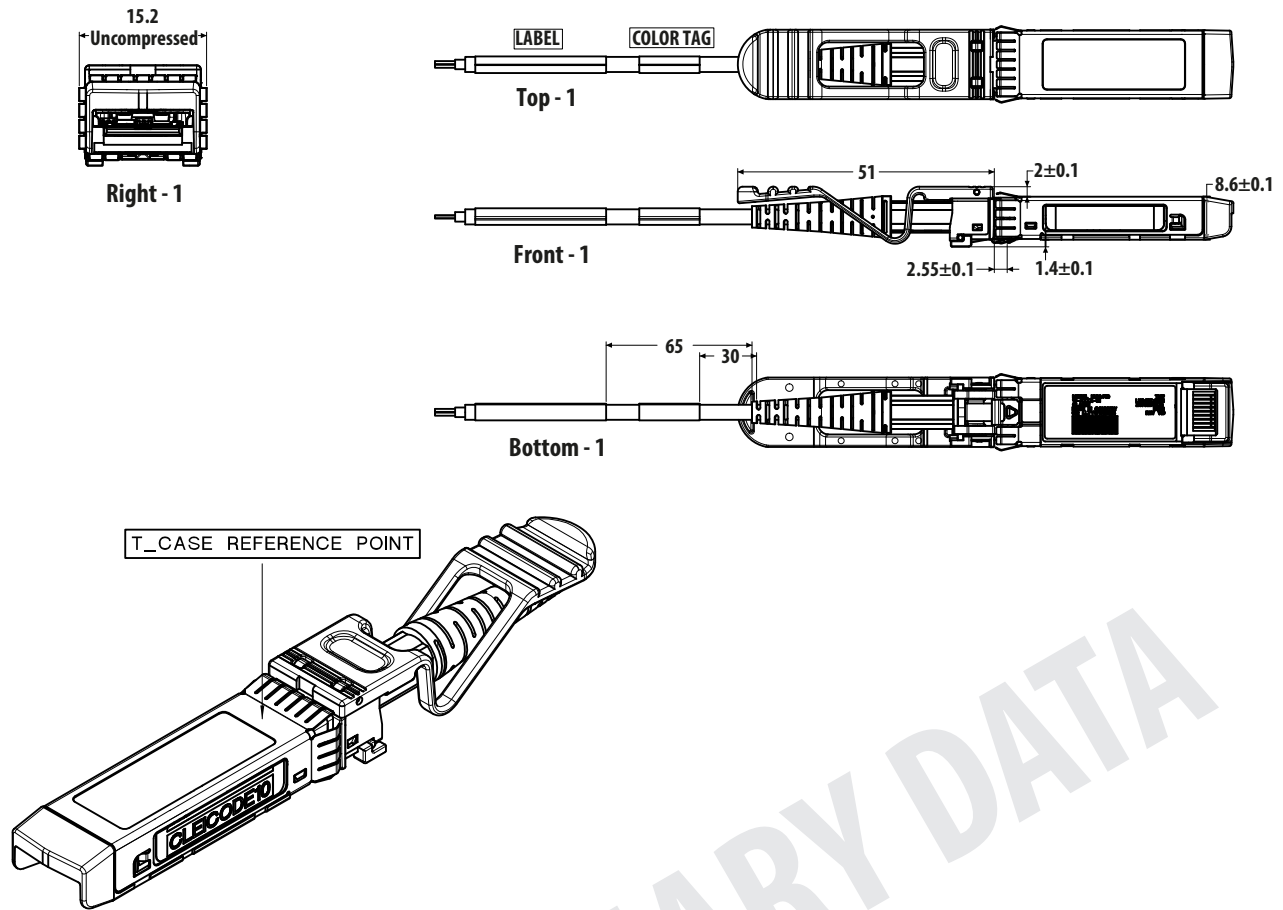

Key Parameters

Parameter	Value	Units	Notes
Data rate per lane	From 1 to 10.3125	Gbps	No retimer or CDR devices embedded in the module. Allows operation at datarates below 10.3125 Gbps
Protocols	1 GbE, 10GbE 1/2/4/8/10 GFC SDR/DDR QDR		Ethernet, Fibre Channel, InfiniBand, Other Protocols and Proprietary Datarates as well
Power Supply Voltage	3.3	V	± 5%
Temperature Range	0 - 70	°C	
Wavelength	850	nm	
Bit Error Rate Performance	1E-15		
Management Interface	Two-Wire Serial		Memory Map access Page A0h only per SFF-8472 Revision 11.0
Laser Output Power	Class 1		EN 60825-1 2007, EN 60825-2 A2 2010
Power consumption per end	275	mW	Nominal Power
Mechanical Specification			Mechanical specifications per SFF Committee SFF-8432 Improved Pluggable Formfactor "IPF" Can be installed in any INF-8074 or SFF-8431/2 compliant Small Form Pluggable (SFP) port
Electrical Interface	20	pins	SFF Committee SFF 8431 Specifications for Enhanced 8.5 and 10 Gigabit Small Form Factor Pluggable Module "SFP+"

For product information and a complete list of distributors, please go to our website: www.avagotech.com

Avago, Avago Technologies, and the A logo are trademarks of Avago Technologies in the United States and other countries. Data subject to change. Copyright © 2005-2014 Avago Technologies. All rights reserved. AV02-4473EN - March 21, 2014

Avago
TECHNOLOGIES