

阅读申明

- 1.本站收集的数据手册和产品资料都来自互联网，版权归原作者所有。如读者和版权方有任何异议请及时告之，我们将妥善解决。
- 2.本站提供的中文数据手册是英文数据手册的中文翻译，其目的是协助用户阅读，该译文无法自动跟随原稿更新，同时也可能存在翻译上的不当。建议读者以英文原稿为参考以便获得更精准的信息。
- 3.本站提供的产品资料，来自厂商的技术支持或者使用者的心得体会等，其内容可能存在描述上的差异，建议读者做出适当判断。
- 4.如需与我们联系，请发邮件到marketing@iczoom.com，主题请标有“数据手册”字样。

Read Statement

1. The datasheets and other product information on the site are all from network reference or other public materials, and the copyright belongs to the original author and original published source. If readers and copyright owners have any objections, please contact us and we will deal with it in a timely manner.
2. The Chinese datasheets provided on the website is a Chinese translation of the English datasheets. Its purpose is for reader's learning exchange only and do not involve commercial purposes. The translation cannot be automatically updated with the original manuscript, and there may also be improper translations. Readers are advised to use the English manuscript as a reference for more accurate information.
3. All product information provided on the website refer to solutions from manufacturers' technical support or users the contents may have differences in description, and readers are advised to take the original article as the standard.
4. If you have any questions, please contact us at marketing@iczoom.com and mark the subject with "Datasheets" .

HFBR-14xxZ and HFBR-24xxZ Series

Low-Cost, 820 nm Miniature Link Fiber Optic Components with ST®, SMA, SC and FC Ports



Data Sheet



Description

The 820 nm Miniature Link Series of components is designed to provide cost-effective, high performance fiber optic communication links for information systems and industrial applications with link distances of several kilometers. With the HFBR-24x6Z, the 125 MHz analog receiver, data rates of up to 160 MBd can be attained.

Transmitters and receivers are directly compatible with popular "industry-standard" connectors: ST®, SMA, SC and FC. They are completely specified with multiple fiber sizes; including 50/125 μm , 62.5/125 μm , 100/140 μm , and 200 μm .

Products are available in various options. For example, transmitters with the improved protection option "P" show an increased ESD resistance to the pins. This "HFBR-141xPxZ" integrated solution is realized by including a Zener diode parallel to the LED.

The HFBR-14x4Z high power transmitter and HFBR-24x6Z 125 MHz receiver pair up to provide a duplex solution optimized for 100 Base-SX. 100Base-SX is a Fast Ethernet Standard (100 Mbps) at 850 nm on multimode fiber.

Evaluation kits are available for ST products, including transmitter, receiver, eval board and technical literature.

Features

- RoHS compliant
- Meets IEEE 802.3 Ethernet and 802.5 token ring standards
- Meets TIA/EIA-785 100Base-SX standard
- Low-cost transmitters and receivers
- Choice of ST®, SMA, SC or FC ports
- 820 nm wavelength technology
- Signal rates up to 160 MBd
- Link distances up to several kilometers
- Compatible with 50/125 μm , 62.5/125 μm , 100/140 μm , and 200 μm Plastic-Clad Silica (PCS) Fiber
- Repeatable ST connections within 0.2 dB typical
- Unique optical port design for efficient coupling
- Pick and place, and wave solderable
- No board mounting hardware required
- Wide operating temperature range -40 °C to +85 °C
- Conductive port option

Applications

- 100Base-SX Fast Ethernet on 850 nm
- Media/fiber conversion, switches, routers, hubs and NICs on 100Base-SX
- Local area networks
- Computer-to-peripheral links
- Computer monitor links
- Digital cross connect links
- Central office switch/PBX links
- Video links
- Modems and multiplexers
- Suitable for Tempest systems
- Industrial control links

Part Number Guide

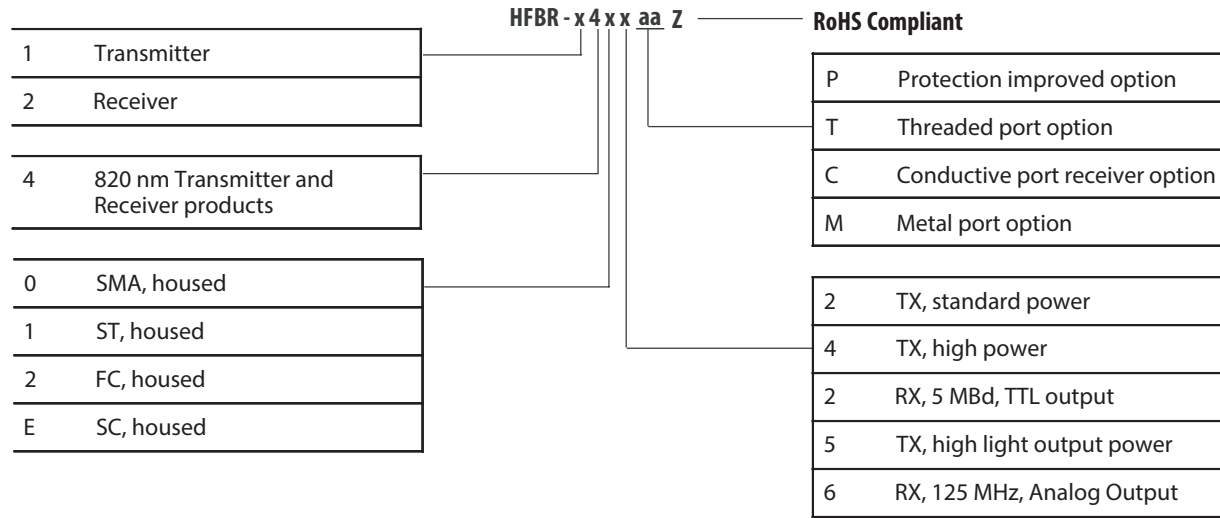

Available Options

HFBR-1402Z	HFBR-1404Z	HFBR-1412PTZ	HFBR-1412PZ	HFBR-1412TMZ	HFBR-1412TZ
HFBR-1412Z	HFBR-1414PTZ	HFBR-1414PZ	HFBR-1414MZ	HFBR-1414TZ	HFBR-1414Z
HFBR-1415TZ	HFBR-1415Z	HFBR-1424Z	HFBR-14E4Z	HFBR-2402Z	HFBR-2406Z
HFBR-2412TCZ	HFBR-2412TZ	HFBR-2412Z	HFBR-2416MZ	HFBR-2416TCZ	HFBR-2416TZ
HFBR-2416Z	HFBR-2422Z	HFBR-24E2Z	HFBR-24E6Z		

Note:

For better readability of the electrical and optical specifications, all available options (P, T, C and M) are covered by the “HFBR-x4xxZ” product name; exceptions are explicitly noted.

Link Selection Guide

Data rate (MBd)	Distance (m)	Transmitter	Receiver	Fiber Size (µm)	Evaluation Kit
5	1500	HFBR-14x2Z	HFBR-24x2Z	62.5/125	HFBR-0410Z
20	2700	HFBR-14x4Z/14x5Z	HFBR-24x6Z	62.5/125	HFBR-0416Z
32	2200	HFBR-14x4Z/14x5Z	HFBR-24x6Z	62.5/125	HFBR-0416Z
55	1400	HFBR-14x4Z/14x5Z	HFBR-24x6Z	62.5/125	HFBR-0416Z
125	700	HFBR-14x4Z/14x5Z	HFBR-24x6Z	62.5/125	HFBR-0416Z
155	600	HFBR-14x4Z/14x5Z	HFBR-24x6Z	62.5/125	HFBR-0416Z
160	500	HFBR-14x4Z/14x5Z	HFBR-24x6Z	62.5/125	HFBR-0416Z

For additional information about specific links, see the individual link descriptions.

The HFBR-1415Z can be used for increased power budget or for lower driving current for the same Data-Rates and Link-Distances.

Options

In addition to the various port styles available for the HFBR- 0400Z series products, there are also several extra options that can be ordered. To order an option, simply place the corresponding option number at the end of the part number. See page 2 for available options.

Option P (Protection improved option)

- Designed to withstand electrostatic discharge (ESD) of 2 kV (HBM) to the pins
- Available on TX with non-conductive ST and non-conductive threaded ST ports

Option T (Threaded Port Option)

- Allows ST style port components to be panel mounted
- Compatible with all current makes of ST® multimode connectors
- Mechanical dimensions are compliant with MIL-STD- 83522/13
- Maximum wall thickness when using nuts and washers from the HFBR-4411Z hardware kit is 2.8 mm (0.11 inch)
- Available on all ST ports

Option C (Conductive Port Receiver Option)

- Designed to withstand electrostatic discharge (ESD) of 25 kV to the optical port
- Significantly reduces effect of electromagnetic interference (EMI) on receiver sensitivity
- Allows designer to separate the signal and conductive port grounds
- Recommended for use in noisy environments
- Available on threaded ST port style receivers only
- The conductive port is connected to Pins 1, 4, 5 and 8 through the Port Grounding Path Insert

Option M (Metal Port Option)

- Nickel plated aluminum connector receptacle
- Designed to withstand electrostatic discharge (ESD) of 15 kV to the optical port
- Significantly reduces effect of electromagnetic interference (EMI) on receiver sensitivity
- Allows designer to separate the signal and metal port grounds
- Recommended for use in very noisy environments
- Available on ST and threaded ST ports
- The metal port is connected to Pins 1, 4, 5 and 8 through the Port Grounding Path Insert

Applications Support Guide

This section gives the designer information necessary to use the 820 nm Miniature Link Series components to make a functional optical transmission link.

Avago offers evaluation kits for hands-on experience with fiber optic products as well as a wide range of application notes complete with circuit diagrams and board layouts.

Furthermore, Avago's application support group is always ready to assist with any design consideration.

Application Literature

Title	Description
Application Note 1065	Complete Solutions for IEEE 802.5J Fiberoptic Token Ring
Application Note 1121	DC to 32 MBd Fiberoptic Solutions
Application Note 1122	2 to 70 MBd Fiberoptic Solutions
Application Note 1123	20 to 160 MBd Fiberoptic Solutions
Application Note 1137	Generic Printed Circuit Layout Rules

Evaluation Kits

Avago offers fiber optic kits that facilitate a simple means to evaluate and experience our products. These fiber optic kits contain all the components and tools required for customers to quickly evaluate and access the value of our products within their respective applications.

HFBR-0410Z ST Evaluation Kit DC to 5 MBd 820 nm Fiber Optic Eval Kit

Contains the following:

- One HFBR-1412Z transmitter
- One HFBR-2412Z receiver
- Eval board
- Related literature

HFBR-0416Z Evaluation Kit 125 MBd 820 nm Fiber Optic Eval Kit

Contains the following:

- One HFBR-1414Z transmitter
- One HFBR-2416Z receiver
- Eval board
- Related literature

Package and Handling Information

Package Information

All transmitters and receivers of the 820 nm Miniature Link Series are housed in a low-cost, dual-inline package that is made of high strength, heat resistant, chemically resistant, and UL 94V-O flame retardant plastic (UL File #E121562). The transmitters are easily identified by the light grey color connector port. The receivers are easily identified by the dark grey color connector port. (Black color for conductive port). The package is designed for pick and place and wave soldering so it is ideal for high volume production applications.

Handling and Design Information

Each part comes with a protective port cap or plug covering the optics. Note: This plastic or rubber port cap is made to protect the optical path during assembly. It is not meant to remain on the part for a long period. These caps/plugs will vary by port style. When soldering, it is advisable to leave the protective cap on the unit to keep the optics clean. Good system performance requires clean port optics and cable ferrules to avoid obstructing the optical path.

Clean compressed air often is sufficient to remove particles of dirt; methanol on a cotton swab also works well.

Recommended Chemicals for Cleaning/Degreasing 820 nm Miniature Link Products

Alcohols: methyl, isopropyl, isobutyl.

Aliphatics: hexane, heptane, Other: soap solution, naphtha.

Do not use partially halogenated hydrocarbons (such as 1,1,1 trichloroethane), ketones (such as MEK), acetone, chloroform, ethyl acetate, methylene dichloride, phenol, methylene chloride, or N-methylpyrrolidone. Also, Avago does not recommend the use of cleaners that use halogenated hydrocarbons because of their potential environmental harm.

Mechanical Dimensions - SMA Port

HFBR-x40xZ

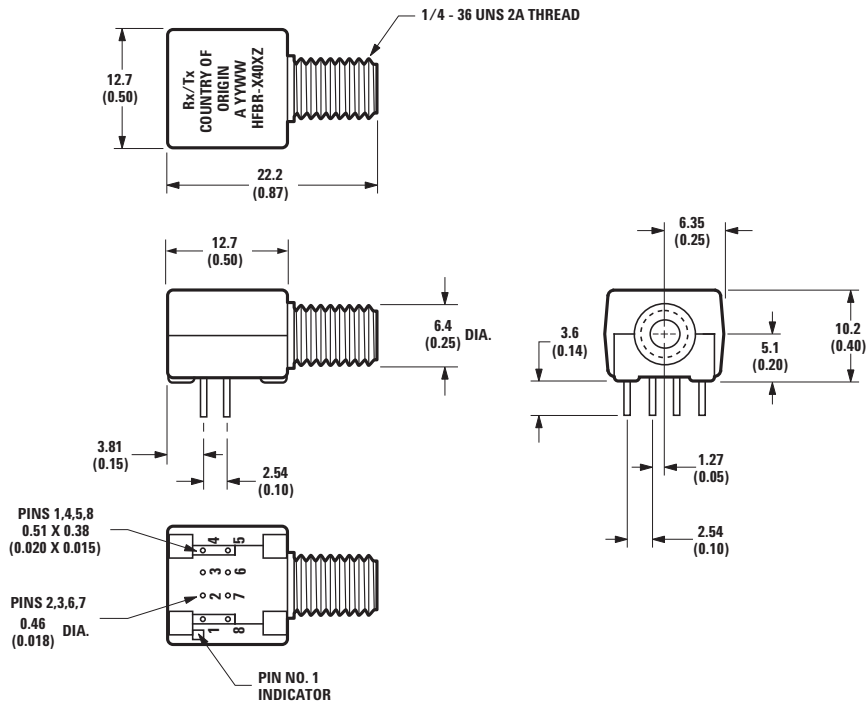

Dimensions in mm (inches)

Mechanical Dimensions - ST Port

HFBR-x41xZ

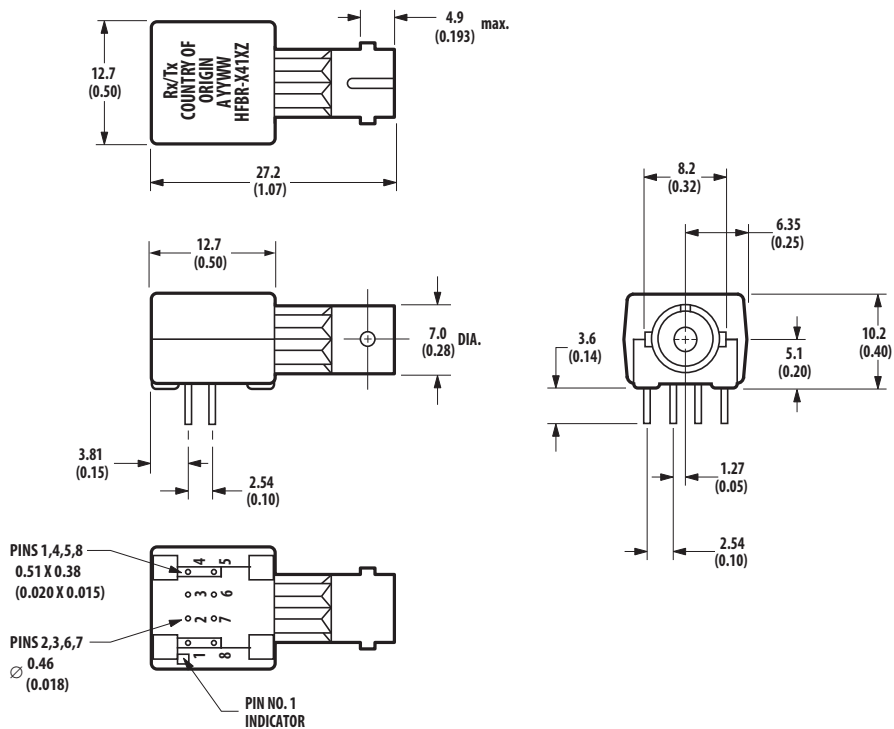

Dimensions in mm (inches)

Mechanical Dimensions - Metal ST Port

HFBR-x41xMZ

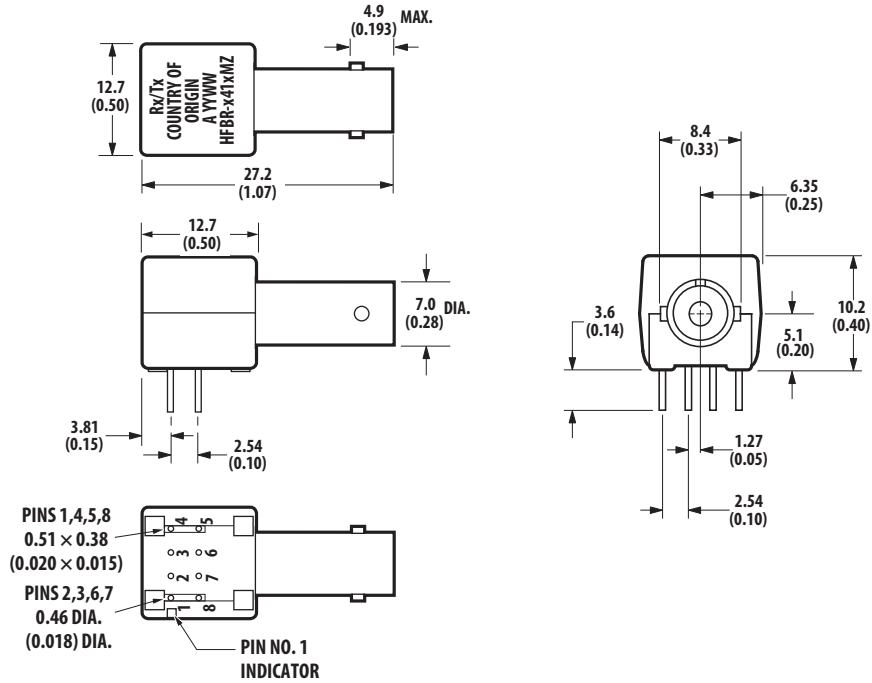

Dimensions in mm (inches)

Mechanical Dimensions - Threaded ST Port

HFBR-x41xTZ

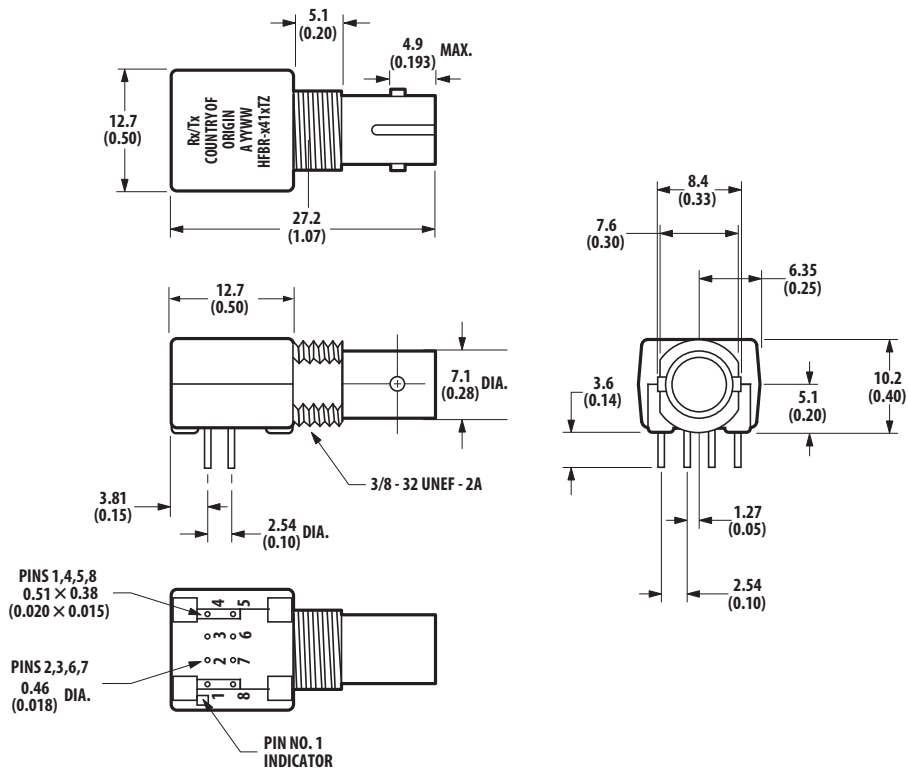

Dimensions in mm (inches)

Mechanical Dimensions - FC Port

HFBR-x42xZ

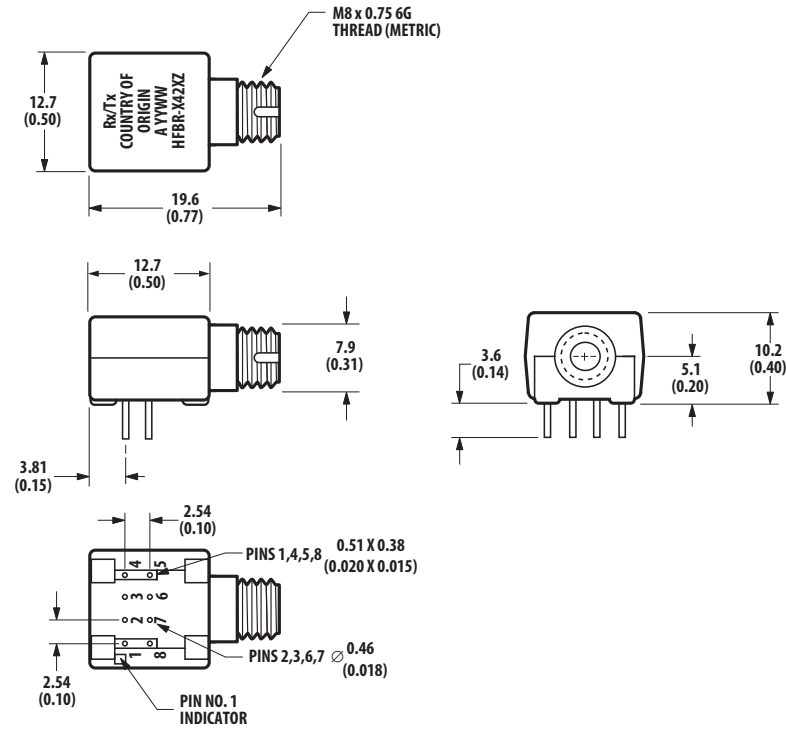

Dimensions in mm (inches)

Mechanical Dimensions - SC Port

HFBR-x4ExZ

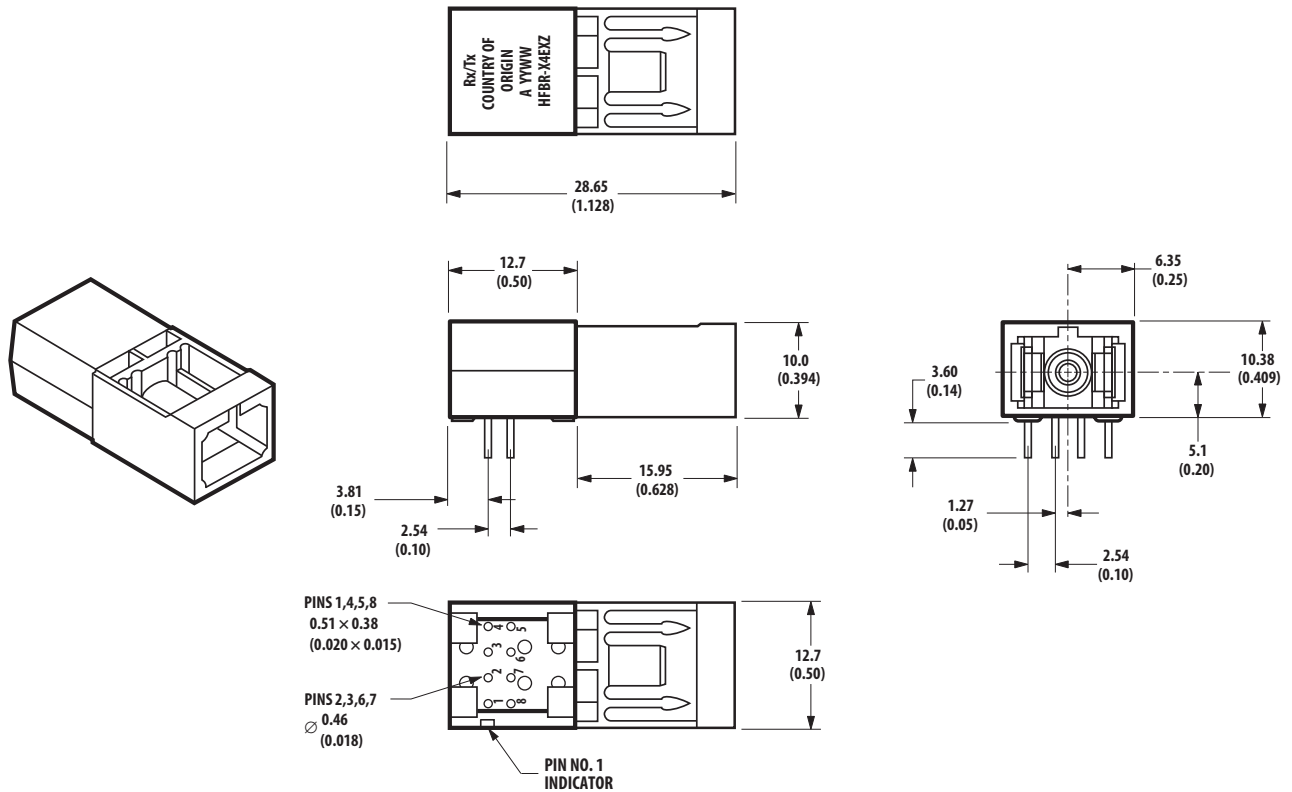

Dimensions in mm (inches)

Cross-Sectional View

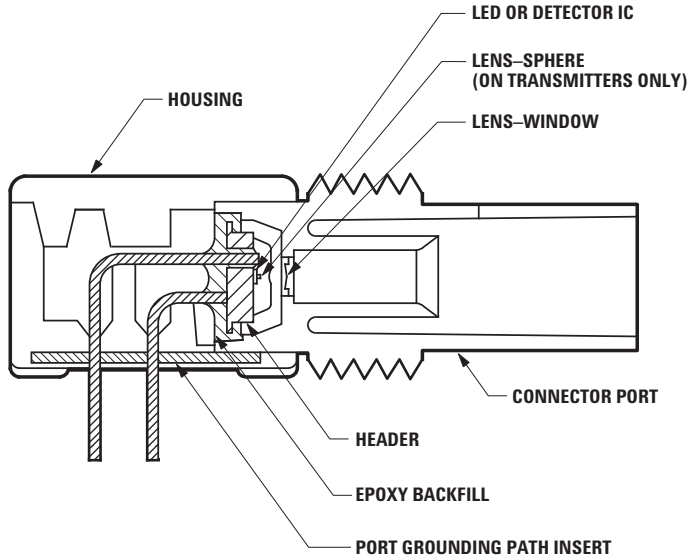
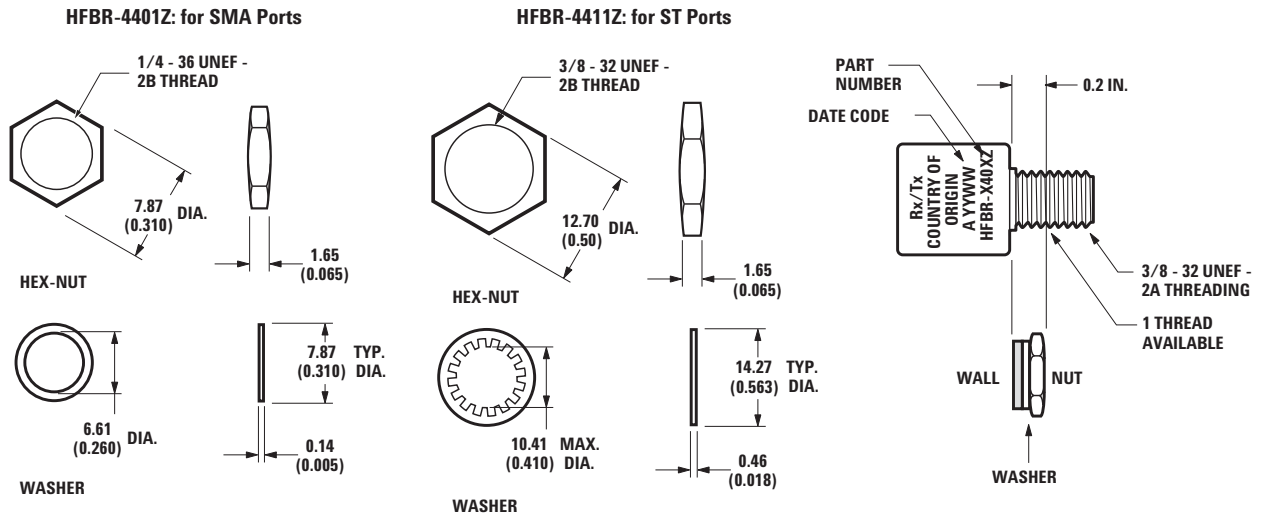

Figure 1. HFBR-x41xTZ ST Series Cross-Sectional View

Panel Mount Hardware



(Each HFBR-4401Z and HFBR-4411Z kit consists of 100 nuts and 100 washers).

Dimensions in mm (inches)

Port Cap Hardware

HFBR-4402Z: 500 SMA Port Caps

HFBR-4120Z: 500 ST Port Plugs

Typical Link Data

The following technical data is taken from 5MBd and 155MBd link using the 820nm Miniature Link Series. This data is meant to be regarded as an example of typical link performance for a given design and does not call out any link limitations.

5 MBd Link (HFBR-14xxZ/24x2Z)

Link Performance -40 °C to +85 °C unless otherwise specified

Parameter	Symbol	Min.	Typ.	Max.	Units	Conditions	Reference
Optical Power Budget with 50/125 μm fiber	OPB ₅₀	4.2	9.6		dB	HFBR-14x4Z/24x2Z NA = 0.2	Note 1
Optical Power Budget with 62.5/125 μm fiber	OPB _{62.5}	8.0	15		dB	HFBR-14x4Z/24x2Z NA = 0.27	Note 1
Optical Power Budget with 100/140 μm fiber	OPB ₁₀₀	8.0	15		dB	HFBR-14x2Z/24x2Z NA = 0.30	Note 1
Optical Power Budget with 200 μm fiber	OPB ₂₀₀	13.0	20		dB	HFBR-14x2Z/24x2Z NA = 0.37	Note 1
Data Rate		dc		5	MBd		Note 2
Propagation Delay LOW to HIGH	t _{PLH}		72		ns		
Propagation Delay HIGH to LOW	t _{PHL}		46		ns	T _A = +25 °C P _R = -21 dBm peak Fiber cable length = 1 m	Figures 6, 7, 8
System Pulse Width Distortion	t _{PLH} - t _{PHL}		26		ns		
Bit Error Rate	BER			10 ⁻⁹		Data rate < 5 MBd P _R > -24 dBm peak	

Notes:

- Optical Power Board at T_A = -40 to +85 °C, V_{CC} = 5.0 V dc, I_{F ON} = 60 mA. P_R = -24 dBm peak.
- Data rate limit is based on these assumptions:
 - 50% duty factor modulation, e.g., Manchester I or BiPhase Manchester II
 - Continuous data
 - PLL Phase Lock Loop demodulation
 - TTL threshold.

5 MBd Logic Link Design

The resistor R1 is the only significant element in the drive circuit (see Figure 2) that limits the current through the LED, apart from the gate's output port. Depending on the actual gate used, the voltage drop on the output port V_{port} could be neglected. The forward voltage value, V_F , of the LED depends on the desired LED current and on the temperature (see Figure 9). Make sure you take this behavior into account for the calculations.

The curves in Figure 3, Figure 4, and Figure 5 are constructed assuming no inline splice or any additional system loss. Besides fiber attenuation, for correct power budget calculation, make sure you take into account the effect of bending, humidity, ambient temperature, aging and other relevant influences. All these additional losses reduce the achievable link distance accordingly.

For calculating the LED's aging effect, an additional loss of about 1.5 dB is recognized.

The following example will illustrate the technique for selecting the appropriate value of I_F and R1:

$$R_1 = \frac{V_{CC} - V_F}{I_F}$$

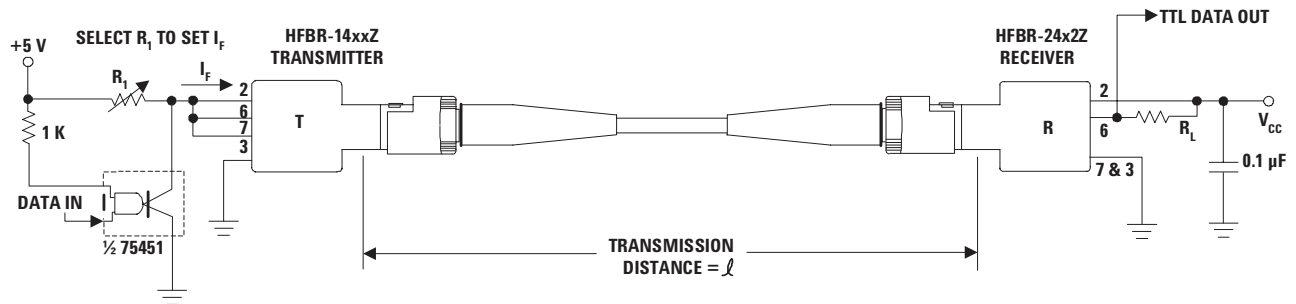

Note:

A bypass capacitor (0.01 μ F to 0.1 μ F ceramic) must be connected from pin 2 to pin 7 of the receiver. Total lead length between both ends of the capacitor and the pins should not exceed 20 mm.

Figure 2. Typical Circuit Configuration

The following diagrams (Figure 3 to Figure 5) serve as an aid in Link Design and are based on theoretical calculations. For broad use, no additional effects such as aging were taken into account. The additional losses and the individual safety buffer values should be added separately. These diagrams reflect the pure viewing of power budget and do not allow conclusions about the actual link quality.

Maximum distance required = 2000 meters by using HFBR-14x4Z/24x2Z logic link with 62.5/125 μ m fiber.

Figure 4 shows the "worst-case" drive current of about 43 mA for reaching a distance of about 2000 meters.

Figure 9 shows the transmitter forward voltage of about $V_F = 1.62$ V. If the typical circuit configuration (Figure 2) is used at $V_{CC} = 5.0$ V, the resistor value "R1" should be chosen to 78.6 Ω (3.38 V/43 mA) for reaching driver current of about 43 mA.

Page 16 shows the guaranteed HFBR-14x4Z's optical output power limit of -16.0 dBm (for driver current of 60 mA) over the entire temperature range.

Figure 10 shows the normalized typical output power. When the transmitter will be driven with 43 mA the optical output power is about 0.70 or -1.55 dB lower than at 60 mA.

With an assumed fiber attenuation of 3.2 dB/km and the reduced driver current of 43 mA, the minimum optical output power at fiber end is about -24 dBm, which is equal to the receiver sensitivity over the entire temperature range.

For balancing the individual additional system losses, the driver current must be increased accordingly.

Overdrive: Maximum optical output power of Tx combined with receiver sensitivity of -10 dBm over the entire temperature range.

Typical 25 °C: Typical optical output power of Tx combined with receiver sensitivity of -25.4 dBm at $T_A = 25$ °C.

Worst Case: Minimum optical output power of Tx combined with receiver sensitivity of -24 dBm over the entire temperature range.

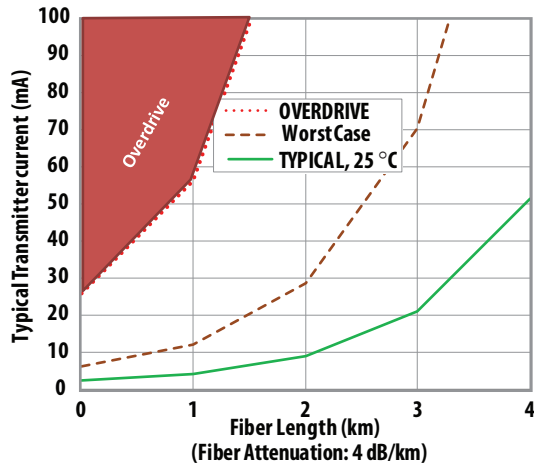

Figure 3. Typical HFBR-14x4xZ/HFBR-24x2xZ Link with 100/140 μm Fiber

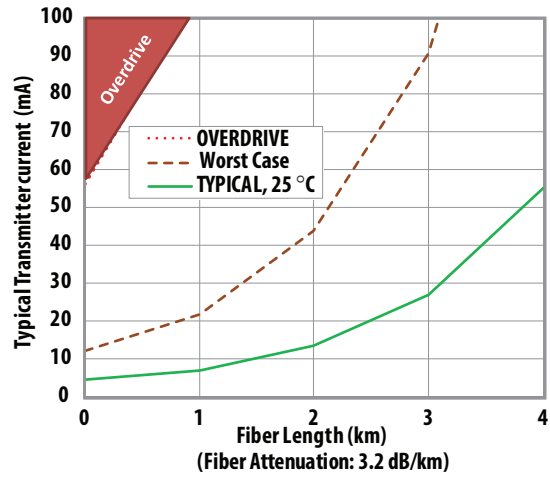

Figure 4. Typical HFBR-14x4xZ/HFBR-24x2xZ Link with 62.5/125 μm Fiber

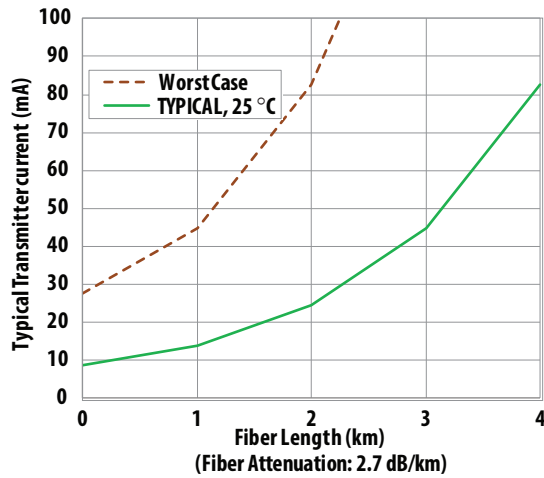

Figure 5. Typical HFBR-14x4xZ/HFBR-24x2xZ Link with 50/125 μm Fiber

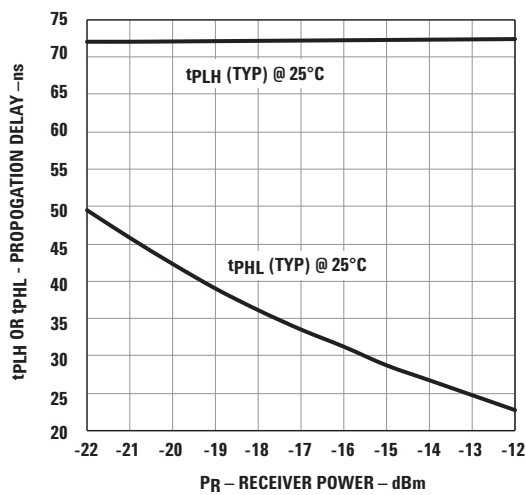

Figure 6. Typical Propagation Delay Times of Link (HFBR-14x4Z/HFBR-24x2Z) measured at $T_A=25^\circ\text{C}$, 5 MBd and with 1 m of Cable

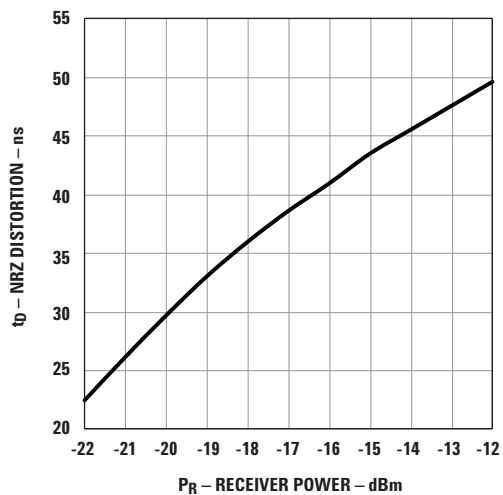

Figure 7. Typical Pulse Width Distortion of Link (HFBR-14x4Z/HFBR-24x2Z) measured at $T_A=25^\circ\text{C}$, 5 MBd and with 1 m of Cable

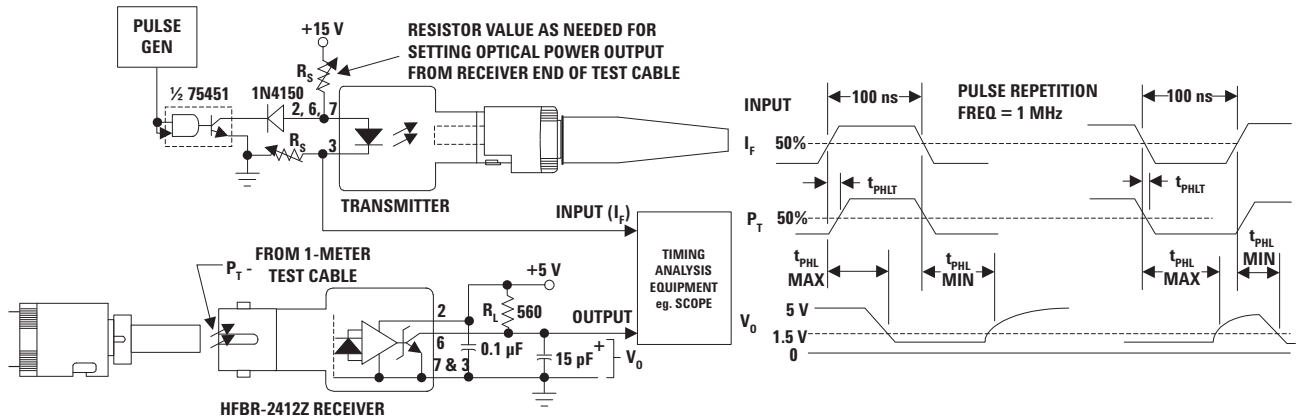

Figure 8. System Propagation Delay Test Circuit and Waveform Timing Definitions

155 MBd Link (HFBR-14x4Z/24x6Z)

Typical Link Performance

Parameter	Symbol	Min.	Typ. [1,2]	Max.	Units	Conditions	Reference
Optical Power Budget with 50/125 μm fiber	OPB ₅₀		13.9		dB	NA = 0.2	Note 2
Optical Power Budget with 62.5/125 μm fiber	OPB ₆₂		17.7		dB	NA = 0.27	
Optical Power Budget with 100/140 μm fiber	OPB ₁₀₀		17.7		dB	NA = 0.30	
Optical Power Budget with 200 μm PCS fiber	OPB ₂₀₀		22.0		dB	NA = 0.35	
Data Format 20% to 80% Duty Factor		20		160	MBd		
System Pulse Width Distortion	$ t_{PLH} - t_{PHL} $		1		ns	PR = -7 dBm peak 1 m 62.5/125 μm fiber	
Bit Error Rate	BER		10^{-9}			Data rate < 100 MBd PR > -31 dBm peak	Note 2

Notes:

1. Typical data at $T_A = +25^\circ\text{C}$, $V_{CC} = 5.0 V_{DC}$, PECL serial interface.
2. Typical OPB was determined at a probability of error (BER) of 10^{-9} . Lower probabilities of error can be achieved with short fibers that have less optical loss.

HFBR-14x2Z/14x4Z/14x5Z Low-Cost High-Speed Transmitters

Description

The HFBR-14xxZ fiber optic transmitter contains an 820 nm AlGaAs emitter capable of efficiently launching optical power into four different optical fiber sizes: 50/125 μm , 62.5/125 μm , 100/140 μm , and 200 μm Plastic-Clad Silica (PCS). This allows the designer flexibility in choosing the fiber size. The HFBR-14xxZ is designed to operate with the Avago Technologies HFBR-24xxZ fiber optic receivers.

The HFBR-14xxZ transmitter's high coupling efficiency allows the emitter to be driven at low current levels resulting in low power consumption and increased reliability of the transmitter. The HFBR-14x4Z high power transmitter is optimized for small size fiber and typically can launch -15.8 dBm optical power at 60 mA into 50/125 μm fiber and -12 dBm into 62.5/125 μm fiber. The HFBR-14x2Z standard transmitter typically can launch -12 dBm of optical power at 60 mA into 100/140 μm fiber cable. It is ideal for large size fiber such as 100/140 μm . The high launched optical power level is useful for systems where star couplers, taps, or inline connectors create large fixed losses.

For 820 nm Miniature Link transmitters with protection improved option "P" a Zener diode parallel to the LED was implemented. Therefore, a higher ESD capability could be attained.

Note: Parameters "reverse input voltage" and "diode capacitance" for "HFBR-141xPxZ" transmitters deviate from the non P-parts.

Regulatory Compliance - Targeted Specifications

Feature	Performance	Reference
Electrostatic Discharge (ESD)	Class 1B (>500 V, <1000 V) - Human Body Model	Note 1, 2

Absolute Maximum Ratings

Parameter	Symbol	Min.	Max.	Units	Reference
Storage Temperature	T _S	-55	+85	°C	
Operating Temperature	T _A	-40	+85	°C	
Lead Soldering Cycle					
Temp			+260	°C	
Time			10	sec	
Forward Input Current					
Peak	I _{FPK}		200	mA	Note 3
dc	I _{Fdc}		100	mA	
Reverse Input Voltage	VBR		1.8	V	
			0.3	V	Note 4
ESD (Human-body model)	ESD		2000	V	Note 1, 4

Notes:

- ESD capability for all pins HBM (Human Body Model) according JEDEC JESD22-A114.
- Valid for not protection improved transmitter option
- For I_{FPK} > 100 mA, the time duration should not exceed 2 ns.
- Only valid for HFBR-141xPxZ (Protection improved option).

Housed Product

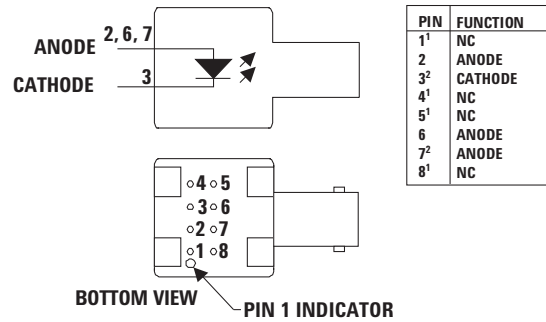

NOTES:

- PINS 1, 4, 5 AND 8 ARE ELECTRICALLY CONNECTED.
- PINS 2, 6 AND 7 ARE ELECTRICALLY CONNECTED TO THE HEADER.

Consistent coupling efficiency is assured by the double-lens optical system (Figure 1 on page 9). Power coupled into any of the three fiber types varies less than 5 dB from part to part at a given drive current and temperature. Consistent coupling efficiency reduces receiver dynamic range requirements, which allows for longer link lengths.

Electrical/Optical Specifications -40 °C to +85 °C unless otherwise specified.

Parameter	Symbol	Min.	Typ. [2]	Max.	Units	Conditions	Reference
Forward Voltage	V_F	1.48	1.70	2.09	V	$I_F = 60$ mA dc	Figure 9
			1.84			$I_F = 100$ mA dc	
Forward Voltage Temperature Coefficient	$\Delta V_F/\Delta T$		-0.22		mV/K	$I_F = 60$ mA dc	Figure 9
			-0.18			$I_F = 100$ mA dc	
Reverse Input Voltage	V_{BR}	1.8	3.8		V	$I_F = -100$ μ A dc	Note 10
		0.3	0.7		V	$I_F = -100$ μ A dc	
Peak Emission Wavelength	λ_P	792	820	865	nm		
Diode Capacitance	C_T		55		pF	$V = 0, f = 1$ MHz	Note 10
			70		pF	$V = 0, f = 1$ MHz	
Optical Power Temperature Coefficient	$\Delta P_T/\Delta T$		-0.006		dB/K	$I = 60$ mA dc	
			-0.010			$I = 100$ mA dc	
Thermal Resistance	θ_{JA}		490		K/W		Notes 3, 8
14x2Z Numerical Aperture	NA		0.49				
14x4Z Numerical Aperture	NA		0.31				
14x2Z Optical Port Diameter	D		290		μ m		Note 4
14x4Z Optical Port Diameter	D		150		μ m		Note 4

HFBR-14x2Z Output Power Measured Out of 1 Meter of Cable

Parameter	Symbol	Min.	Typ.	Max.	Units	Conditions	Reference
50/125 μ m Fiber Cable	P_{T50}	-21.8	-18.8	-16.8	dBm peak	$T_A = +25$ °C, $I_F = 60$ mA	Notes 5, 6, 9
				-15.8	dBm peak	$T_A = -40$ °C to +85 °C, $I_F = 60$ mA	
		-20.3	-16.8	-14.4	dBm peak	$T_A = +25$ °C, $I_F = 100$ mA	Figure 10
		-21.9		-13.8	dBm peak	$T_A = -40$ °C to +85 °C, $I_F = 100$ mA	
62.5/125 μ m Fiber Cable	P_{T62}	-19.0	-16.0	-14.0	dBm peak	$T_A = +25$ °C, $I_F = 60$ mA	
				-13.0	dBm peak	$T_A = -40$ °C to +85 °C, $I_F = 60$ mA	
		-17.5	-14.0	-11.6	dBm peak	$T_A = +25$ °C, $I_F = 100$ mA	
		-19.1		-11.0	dBm peak	$T_A = -40$ °C to +85 °C, $I_F = 100$ mA	
100/140 μ m Fiber Cable	P_{T100}	-15.0	-12.0	-10	dBm peak	$T_A = +25$ °C, $I_F = 60$ mA	
				-9.0	dBm peak	$T_A = -40$ °C to +85 °C, $I_F = 60$ mA	
		-13.5	-10.0	-7.6	dBm peak	$T_A = +25$ °C, $I_F = 100$ mA	
		-15.1		-7.0	dBm peak	$T_A = -40$ °C to +85 °C, $I_F = 100$ mA	
200 μ m PCS Fiber Cable	P_{T200}	-10.0	-7.0	-5.0	dBm peak	$T_A = +25$ °C, $I_F = 60$ mA	
				-4.0	dBm peak	$T_A = -40$ °C to +85 °C, $I_F = 60$ mA	
		-8.5	-5.0	-2.6	dBm peak	$T_A = +25$ °C, $I_F = 100$ mA	
		-10.1		-2.0	dBm peak	$T_A = -40$ °C to +85 °C, $I_F = 100$ mA	

CAUTION: The small junction sizes inherent to the design of these components increase the components' susceptibility to damage from electrostatic discharge (ESD). It is advised that normal static precautions be taken in handling and assembly of these components to prevent damage and/or degradation which may be induced by ESD.

HFBR-14x4Z Output Power Measured out of 1 Meter of Cable

Parameter	Symbol	Min.	Typ. [2]	Max.	Units	Conditions	Reference
50/125 μm Fiber Cable NA = 0.2	P _{T50}	-18.8	-15.8	-13.8	dBm peak	T _A = +25 °C, I _F = 60 mA	Notes 5, 6, 9
		-19.8		-12.8	dBm peak	T _A = -40 °C to +85 °C, I _F = 60 mA	
		-17.3	-13.8	-11.4	dBm peak	T _A = +25 °C, I _F = 100 mA	Figure 10
		-18.9		-10.8	dBm peak	T _A = -40 °C to +85 °C, I _F = 100 mA	
62.5/125 μm Fiber Cable NA = 0.275	P _{T62}	-15.0	-12.0	-10.0	dBm peak	T _A = +25 °C, I _F = 60mA	
		-16.0		-9.0	dBm peak	T _A = -40 °C to +85 °C, I _F = 60 mA	
		-13.5	-10.0	-7.6	dBm peak	T _A = +25 °C, I _F = 100 mA	
		-15.1		-7.0	dBm peak	T _A = -40 °C to +85 °C, I _F = 100 mA	
100/140 μm Fiber Cable NA = 0.3	P _{T100}	-11.5	-8.5	-6.5	dBm peak	T _A = +25 °C, I _F = 60 mA	
		-12.5		-5.5	dBm peak	T _A = -40 °C to +85 °C, I _F = 60 mA	
		-10.0	-6.5	-4.1	dBm peak	T _A = +25 °C, I _F = 100 mA	
		-11.6		-3.5	dBm peak	T _A = -40 °C to +85 °C, I _F = 100 mA	
200 μm PCS Fiber Cable NA = 0.37	P _{T200}	-7.5	-4.5	-2.5	dBm peak	T _A = +25 °C, I _F = 60mA	
		-8.5		-1.5	dBm peak	T _A = -40 °C to +85 °C, I _F = 60 mA	
		-6.0	-2.5	-0.1	dBm peak	T _A = +25 °C, I _F = 100 mA	
		-7.6		0.5	dBm peak	T _A = -40 °C to +85 °C, I _F = 100 mA	

HFBR-14x5Z Output Power Measured out of 1 Meter of Cable

Parameter	Symbol	Min.	Typ.	Max.	Units	Conditions	Reference
50/125 μm Fiber Cable NA = 0.2	P _{T50}	-16.5	-14.3	-11.5	dBm peak	T _A = +25 °C, I _F = 60 mA	Notes 5, 6, 9
		-17.5		-10.5	dBm peak	T _A = -40 °C to 85 °C, I _F = 60 mA	
62.5/125 μm Fiber Cable NA = 0.275	P _{T62}	-12.0	-10.5	-8.0	dBm peak	T _A = +25 °C, I _F = 60 mA	Figure 10
		-13.0		-7.0	dBm peak	T _A = -40 °C to 85 °C, I _F = 60 mA	
200 μm Fiber Cable NA = 0.37	P _{T200}	-6.0	-3.6	0.0	dBm peak	T _A = +25 °C, I _F = 60 mA	
		-7.0		1.0	dBm peak	T _A = -40 °C to 85 °C, I _F = 60 mA	

14x2Z/14x4Z/14x5Z Dynamic Characteristics

Parameter	Symbol	Min.	Typ. [2]	Max.	Units	Conditions	Reference
Rise Time, Fall Time (10% to 90%)	t _r , t _f		4.0	6.5	ns	I _F = 60 mA No pre-bias Figure 11	Note 7
Rise Time, Fall Time (10% to 90%)	t _r , t _f		3.0		ns	I _F = 10 to 100 mA	Figure 12
Pulse Width Distortion	PWD		0.5		ns		Figure 12

Notes:

- For I_{FPK} > 100 mA, the time duration should not exceed 2 ns.
- Typical data at T_A = +25 °C.
- Thermal resistance is measured with the transmitter coupled to a connector assembly and mounted on a printed circuit board.
- D is measured at the plane of the fiber face and defines a diameter where the optical power density is within 10 dB of the maximum.
- P_T is measured with a large area detector at the end of 1 meter of mode stripped cable, with an ST® precision ceramic ferrule (MILSTD-83522/13) for HFBR-141xZ, and with an SMA 905 precision ceramic ferrule for HFBR-140xZ.
- When changing mW to dBm, the optical power is referenced to 1 mW. Optical Power P(dBm) = 10log (P(mW) / 1mW)
- Pre-bias is recommended if signal rate >10 MBd, see recommended drive circuit in Figure 11.
- Pins 2, 6 and 7 are welded to the anode header connection to minimize the thermal resistance from junction to ambient. To further reduce the thermal resistance, the anode trace should be made as large as is consistent with good RF circuit design.
- Fiber NA is measured at the end of 2 meters of mode stripped fiber, using the far-field pattern. NA is defined as the sine of the half angle, determined at 5% of the peak intensity point. When using other manufacturer's fiber cable, results will vary due to differing NA values and specification methods.
- Only valid for HFBR-141xPxZ (Protection improved option).

All HFBR-14XXZ LED transmitters are classified as IEC 825-1 Accessible Emission Limit (AEL) Class 1 based upon the current proposed draft scheduled to go in to effect on January 1, 1997. AEL Class 1 LED devices are considered eye safe. Contact your Avago Technologies sales representative for more information.

CAUTION: The small junction sizes inherent to the design of these components increase the components' susceptibility to damage from electrostatic discharge (ESD). It is advised that normal static precautions be taken in handling and assembly of these components to prevent damage and/or degradation which may be induced by ESD.

Recommended Drive Circuits

The circuit used to supply current to the LED transmitter can significantly influence the optical switching characteristics of the LED. The optical rise/fall times and propagation delays can be improved by using the appropriate circuit techniques. The LED drive circuit shown in Figure 11 uses frequency compensation to reduce the typical rise/fall times of the LED and a small pre-bias voltage to minimize propagation delay differences that cause pulse-

width distortion. The circuit will typically produce rise/fall times of 3 ns, and a total jitter including pulse-width distortion of less than 1 ns. This circuit is recommended for applications requiring low edge jitter or high-speed data transmission at signal rates of up to 155 MBd. Component values for this circuit can be calculated for different LED drive currents using the equations shown as follows.

$$R_Y = \frac{(V_{CC} - V_F) + 3.97(V_{CC} - V_F - 1.6V)}{I_{F\ ON} (A)}$$

$$R_{X1} = \frac{1}{2} \left(\frac{R_Y}{3.97} \right)$$

$$R_{EQ2} (\Omega) = R_{X1} - 1$$

$$R_{X2} = R_{X3} = R_{X4} = 3(R_{EQ2})$$

$$C(pF) = \frac{2000\ ps}{R_{X1}(\Omega)}$$

Example for $I_{F\ ON} = 100\ mA$:
 V_F can be obtained from Figure 9 (= 1.84 V).

$$R_Y = \frac{(5 - 1.84) + 3.97(5 - 1.84 - 1.6)}{0.100}$$

$$R_Y = \frac{3.16 + 6.19}{0.100} = 93.5\ \Omega$$

$$R_{X1} = \frac{1}{2} \left(\frac{93.5}{3.97} \right) = 11.8\ \Omega$$

$$R_{EQ2} = 11.8 - 1 = 10.8\ \Omega$$

$$R_{X2} = R_{X3} = R_{X4} = 3(10.8) = 32.4\ \Omega$$

$$C = \frac{2000\ ps}{11.8\ \Omega} = 169\ pF$$

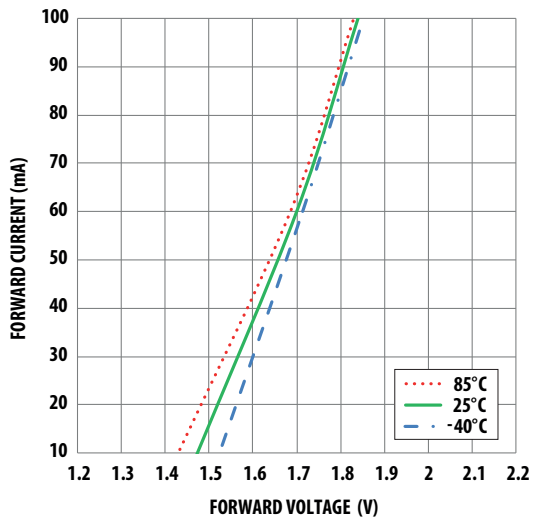

Figure 9. Typical Forward Voltage and Current Characteristics

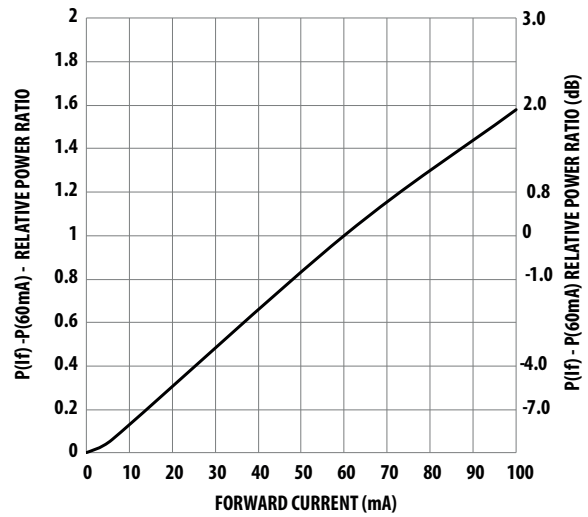

Figure 10. Normalized Typical Transmitter Output vs. Forward Current

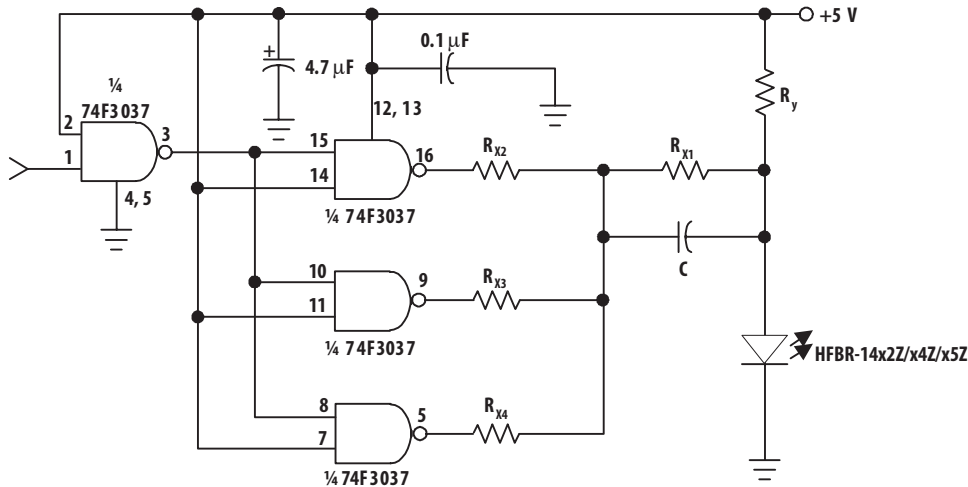

Figure 11. Recommended Drive Circuit

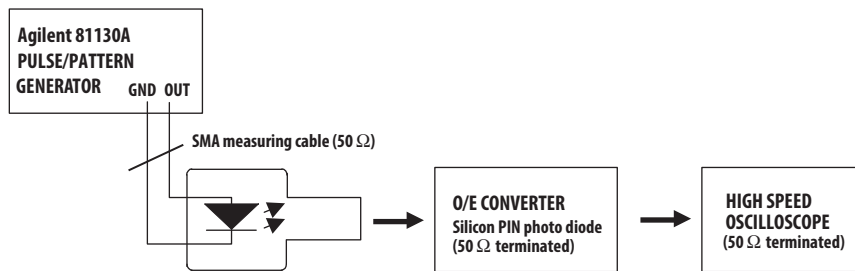

Figure 12. Test Circuit for Measuring t_r , t_f

HFBR-24x2Z Low-Cost 5 MBd Receiver

Description

The HFBR-24x2Z fiber optic receiver is designed to operate with the Avago Technologies HFBR-14xxZ fiber optic transmitter and 50/125 μm , 62.5/125 μm , 100/ 140 μm , and 200 μm Plastic-Clad Silica (PCS) fiber optic cable. Consistent coupling into the receiver is assured by the lensed optical system (Figure 1). Response does not vary with fiber size $\leq 0.100 \mu\text{m}$.

The HFBR-24x2Z receiver incorporates an integrated photo IC containing a photodetector and dc amplifier driving an open-collector Schottky output transistor. The HFBR-24x2Z is designed for direct interfacing to popular logic families. The absence of an internal pull-up resistor allows the open-collector output to be used with logic families such as CMOS requiring voltage excursions much higher than V_{CC} .

Both the open-collector "Data" output Pin 6 and V_{CC} Pin 2 are referenced to "Com" Pin 3, 7. The "Data" output allows busing, strobing and wired "OR" circuit configurations. The transmitter is designed to operate from a single +5 V supply. It is essential that a bypass capacitor (100 nF ceramic) be connected from Pin 2 (V_{CC}) to Pin 3 (circuit common) of the receiver.

Housed Product

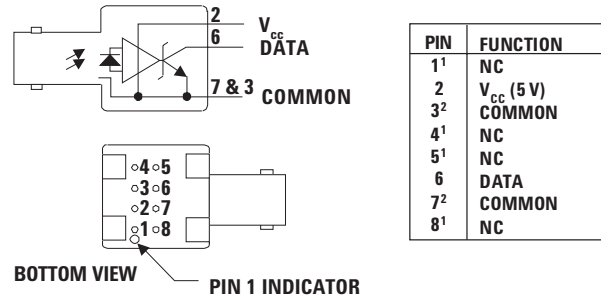

NOTES:

- PINS 1, 4, 5 AND 8 ARE ELECTRICALLY CONNECTED.
- PINS 3 AND 7 ARE ELECTRICALLY CONNECTED TO THE HEADER.

Absolute Maximum Ratings

Parameter	Symbol	Min.	Max.	Units	Reference
Storage Temperature	T_S	-55	+85	$^{\circ}\text{C}$	
Operating Temperature	T_A	-40	+85	$^{\circ}\text{C}$	
Lead Soldering Cycle Temp Time			+260 10	$^{\circ}\text{C}$ sec	Note 1
Supply Voltage	V_{CC}	-0.5	7.0	V	
Output Current	I_O		25	mA	
Output Voltage	V_O	-0.5	18.0	V	
Output Collector Power Dissipation	P_{OAV}		40	mW	
Fan Out (TTL)	N		5		Note 2

Notes:

- 2.0 mm from where leads enter case.
- 8 mA load (5 x 1.6 mA), $R_L = 560 \Omega$.

Electrical/Optical Characteristics -40 °C to + 85 °C unless otherwise specifiedFiber sizes with core diameter $\leq 100 \mu\text{m}$ and $\text{NA} \leq 0.35$, $4.75 \text{ V} \leq V_{\text{CC}} \leq 5.25 \text{ V}$

Parameter	Symbol	Min.	Typ. ^[3]	Max.	Units	Conditions	Reference
High Level Output Current	I_{OH}		5	250	μA	$V_{\text{O}} = 18$, $P_{\text{R}} < -40 \text{ dBm}$	
Low Level Output Voltage	V_{OL}		0.4	0.5	V	$I_{\text{O}} = 8 \text{ m}$, $P_{\text{R}} > -24 \text{ dBm}$	
High Level Supply Current	I_{CCH}		3.5	6.3	mA	$V_{\text{CC}} = 5.25 \text{ V}$, $P_{\text{R}} < -40 \text{ dBm}$	
Low Level Supply Current	I_{CCL}		6.2	10	mA	$V_{\text{CC}} = 5.25 \text{ V}$, $P_{\text{R}} > -24 \text{ dBm}$	
Equivalent NA	NA		0.50				
Optical Port Diameter	D		400		μm		Note 4

Dynamic Characteristics-40 °C to + 85 °C unless otherwise specified; $4.75 \text{ V} \leq V_{\text{CC}} \leq 5.25 \text{ V}$; $\text{BER} \leq 10^{-9}$

Parameter	Symbol	Min.	Typ. ^[3]	Max.	Units	Conditions	Reference
Peak Optical Input Power Logic Level HIGH	P_{RH}			-40 0.1	dBm peak μW peak	$\lambda_{\text{p}} = 820 \text{ nm}$	Note 5
Peak Optical Input Power Logic Level LOW	P_{RL}	-25.4		-9.2	dBm peak	$T_{\text{A}} = +25 \text{ }^{\circ}\text{C}$, $I_{\text{OL}} = 8 \text{ mA}$	Note 5
		2.9		120	μW peak		
Propagation Delay LOW to HIGH	t_{PLHR}	-24.0		-10.0	dBm peak	$T_{\text{A}} = -40 \text{ }^{\circ}\text{C}$ to $+85 \text{ }^{\circ}\text{C}$, $I_{\text{OL}} = 8 \text{ mA}$	Note 6
		4.0		100	μW peak		
Propagation Delay HIGH to LOW	t_{PHLR}		49		ns	$T_{\text{A}} = +25 \text{ }^{\circ}\text{C}$, $P_{\text{R}} = -21 \text{ dBm}$, Data Rate = 5 MBd	

Notes:

- 2.0 mm from where leads enter case.
- 8 mA load (5 x 1.6 mA), $R_{\text{L}} = 560 \Omega$.
- Typical data at $T_{\text{A}} = +25 \text{ }^{\circ}\text{C}$, $V_{\text{CC}} = 5.0 \text{ V}_{\text{dc}}$.
- D is the effective diameter of the detector image on the plane of the fiber face. The numerical value is the product of the actual detector diameter and the lens magnification.
- Measured at the end of 100/140 μm fiber optic cable with large area detector.
- Propagation delay through the system is the result of several sequentially-occurring phenomena. Consequently it is a combination of data-rate-limiting effects and of transmission-time effects. Because of this, the data-rate limit of the system must be described in terms of time differentials between delays imposed on falling and rising edges. As the cable length is increased, the propagation delays increase at 5 ns per meter of length. Data rate, as limited by pulse width distortion, is not affected by increasing cable length if the optical power level at the receiver is maintained.

CAUTION: The small junction sizes inherent to the design of these components increase the components' susceptibility to damage from electrostatic discharge (ESD). It is advised that normal static precautions be taken in handling and assembly of these components to prevent damage and/or degradation which may be induced by ESD.

HFBR-24x6Z Low-Cost 125 MHz Receiver

Description

The HFBR-24x6Z fiber optic receiver is designed to operate with the Avago Technologies HFBR-14xxZ fiber optic transmitters and 50/ 125 μm , 62.5/125 μm , 100/140 μm and 200 μm Plastic-Clad Silica (PCS) fiber optic cable. Consistent coupling into the receiver is assured by the lensed optical system (Figure 1). Response does not vary with fiber size for core diameters of 100 μm or less.

The receiver output is an analog signal which allows follow-on circuitry to be optimized for a variety of distance/data rate requirements. Low-cost external components can be used to convert the analog output to logic compatible signal levels for various data formats and data rates up to 175 MBd. This distance/data rate trade-off results in increased optical power budget at lower data rates which can be used for additional distance or splices.

The HFBR-24x6Z receiver contains a PIN photodiode and low noise transimpedance preamplifier integrated circuit. The HFBR-24x6Z receives an optical signal and converts it to an analog voltage. The output is a buffered emitter

follower. Because the signal amplitude from the HFBR-24x6Z receiver is much larger than from a simple PIN photodiode, it is less susceptible to EMI, especially at high signaling rates. For very noisy environments, the conductive or metal port option is recommended. A receiver dynamic range of 23 dB over temperature is achievable, assuming a Bit Error Rate (BER) of 10^{-9} .

The frequency response is typically dc to 125 MHz. Although the HFBR-24x6Z is an analog receiver, it is compatible with digital systems.

The recommended ac coupled receiver circuit is shown in Figure 14. A $10\ \Omega$ resistor must be connected between pin 6 and the power supply, and a 100 nF ceramic bypass capacitor must be connected between the power supply and ground. In addition, pin 6 should be filtered to protect the receiver from noisy host systems. Refer to AN 1065 for details.

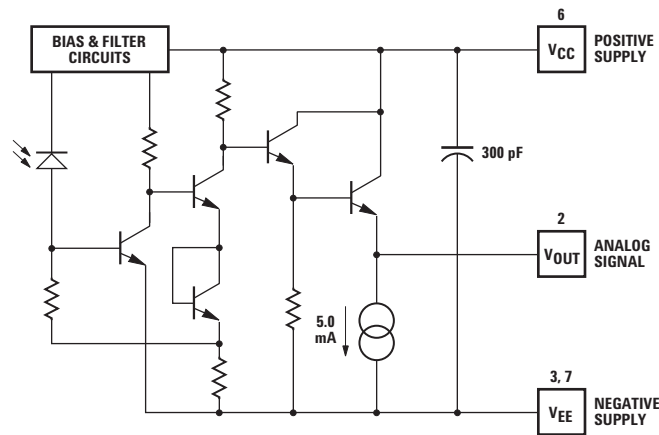
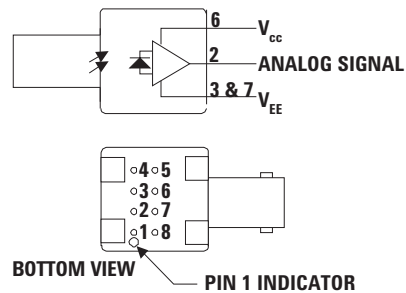

Figure 13. Simplified Schematic Diagram.

Housed Product



PIN	FUNCTION
1 ¹	NC
2	SIGNAL
3 ²	V _{EE}
4 ¹	NC
5 ¹	NC
6	V _{CC}
7 ²	V _{EE}
8 ¹	NC

NOTES:

1. PINS 1, 4, 5 AND 8 ARE ISOLATED FROM THE INTERNAL CIRCUITRY, BUT ARE CONNECTED TO EACH OTHER.
2. PINS 3 AND 7 ARE ELECTRICALLY CONNECTED TO THE HEADER.

CAUTION: The small junction sizes inherent to the design of these components increase the components' susceptibility to damage from electrostatic discharge (ESD). It is advised that normal static precautions be taken in handling and assembly of these components to prevent damage and/or degradation which may be induced by ESD.

Absolute Maximum Ratings

Parameter	Symbol	Min.	Max.	Units	Reference
Storage Temperature	T _S	-55	+85	°C	
Operating Temperature	T _A	-40	+85	°C	
Lead Soldering Cycle Temp Time			+260 10	°C sec	Note 1
Supply Voltage	V _{CC}	-0.5	6.0	V	
Output Current	I _O		25	mA	
Signal Pin Voltage	V _{SIG}	-0.5	V _{CC}	V	

Electrical/Optical Characteristics -40 °C to +85 °C; 4.75 V ≤ Supply Voltage ≤ 5.25 V,

R_{LOAD} = 511 Ω, Fiber sizes with core diameter ≤ 100 μm, and N.A. ≤ 0.35 unless otherwise specified.

Parameter	Symbol	Min.	Typ. [2]	Max.	Units	Conditions	Reference
Responsivity	R _P	5.3	7	9.6	mV/μW	T _A = +25 °C @ 820 nm, 50 MHz	Note 3, 4 Figure 18
		4.5		11.5	mV/μW	T _A = -40°C to +85°C @ 820nm, 50MHz	
RMS Output Noise Voltage	V _{NO}		0.40	0.59	mV	Bandwidth filtered @ 75 MHz P _R = 0 μW	Note 5 Figure 15
				0.70	mV	Unfiltered bandwidth P _R = 0 μW	
Equivalent Input Optical Noise Power (RMS)	PN		-43.0 0.050	-41.4 0.065	dBm μW	Bandwidth filtered @ 75 MHz	
Optical Input Power (Overdrive)	P _R			-7.6 175	dBm peak μW peak	T _A = +25 °C	Note 6 Figure 16
				-8.2 150	dBm peak μW peak	T _A = -40 °C to +85 °C	
Output Impedance	Z _O		30		Ω	Test Frequency = 50 MHz	
dc Output Voltage	V _{O dc}	V _{CC} - 4.2	V _{CC} - 3.1	V _{CC} - 2.4	V	P _R = 0 μW	
Power Supply Current	I _{EE}		9	15	mA	R _{LOAD} = 510 Ω	
Equivalent NA	NA		0.35				
Equivalent Diameter	D		324		μm		Note 7

CAUTION: The small junction sizes inherent to the design of these components increase the components' susceptibility to damage from electrostatic discharge (ESD). It is advised that normal static precautions be taken in handling and assembly of these components to prevent damage and/or degradation which may be induced by ESD.

Dynamic Characteristics

-40 °C to +85 °C; 4.75 V ≤ Supply Voltage ≤ 5.25 V; R_{LOAD} = 511 Ω, C_{LOAD} = 5 pF unless otherwise specified

Parameter	Symbol	Min.	Typ. [2]	Max.	Units	Conditions	Reference
Rise/Fall Time 10% to 90%	t _r , t _f		3.3	6.3	ns	P _R = 100 μW peak	Figure 17
Pulse Width Distortion	PWD		0.4	2.5	ns	P _R = 150 μW peak	Note 8, Figure 16
Overshoot			2		%	P _R = 5 μW peak, t _r = 1.5 ns	Note 9
Bandwidth (Electrical)	BW		125		MHz	-3 dB Electrical	
Bandwidth - Rise Time Product			0.41		Hz • s	Note 10	

Notes:

- 2.0 mm from where leads enter case.
- Typical specifications are for operation at T_A = +25 °C and V_{CC} = +5 V dc.
- For 200 μm PCS fibers, typical responsivity will be 6 mV/mW. Other parameters will change as well.
- Pin #2 should be ac coupled to a load 510 Ω. Load capacitance must be less than 5 pF.
- Measured with a 3 pole Bessel filter with a 75 MHz, -3 dB bandwidth.
- Overdrive is defined at PWD = 2.5 ns.
- D is the effective diameter of the detector image on the plane of the fiber face. The numerical value is the product of the actual detector diameter and the lens magnification.
- Measured with a 10 ns pulse width, 50% duty cycle, at the 50% amplitude point of the waveform.
- Percent overshoot is defined as:

$$\left(\frac{V_{PK} - V_{100\%}}{V_{100\%}} \right) \times 100\%$$

- The conversion factor for the rise time to bandwidth is 0.41 since the HFBR-24x6Z has a second order bandwidth limiting characteristic.

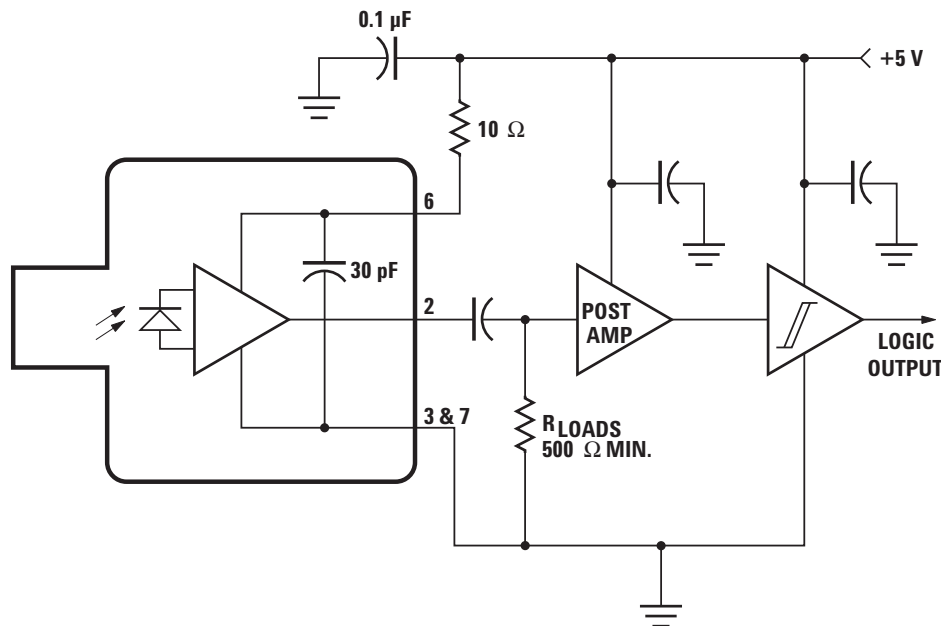

Figure 14. Recommended AC Coupled Receiver Circuit

CAUTION: The small junction sizes inherent to the design of these components increase the components' susceptibility to damage from electrostatic discharge (ESD). It is advised that normal static precautions be taken in handling and assembly of these components to prevent damage and/or degradation which may be induced by ESD.

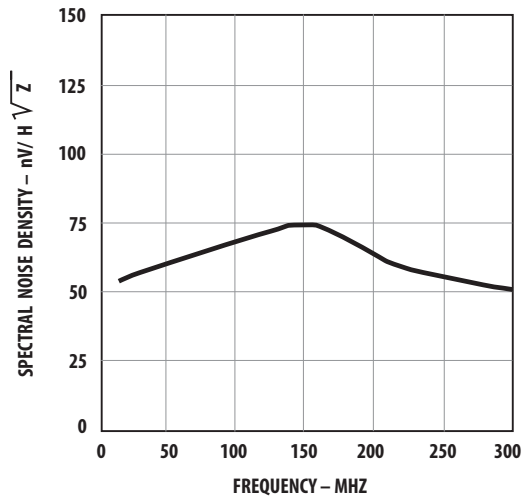

Figure 15. Typical Spectral Noise Density vs. Frequency

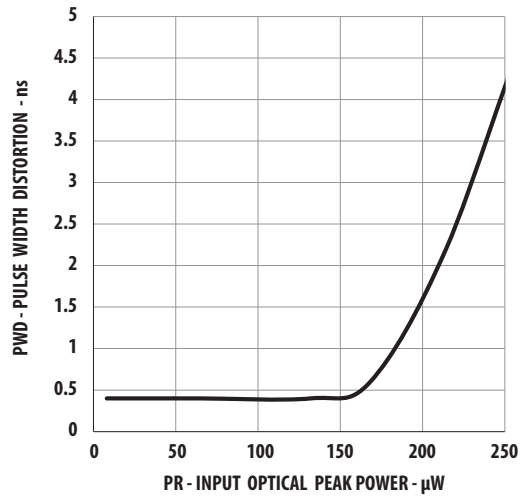

Figure 16. Typical Pulse Width Distortion vs. Peak Input Power

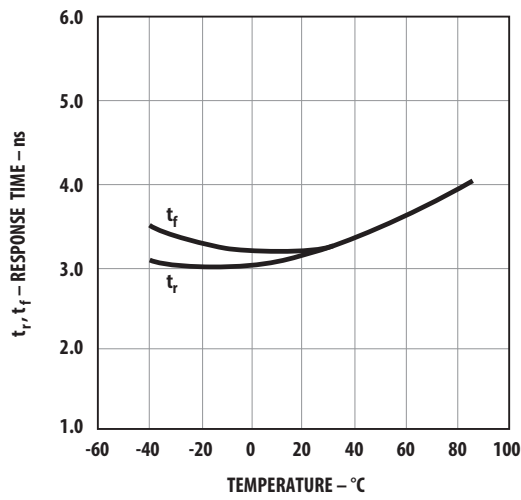

Figure 17. Typical Rise and Fall Times vs. Temperature

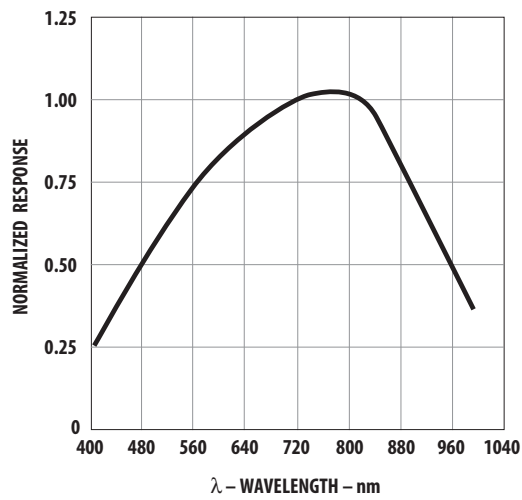

Figure 18. Typical Receiver Spectral Response Normalized to 820 nm

For product information and a complete list of distributors, please go to our web site: www.avagotech.com

Avago, Avago Technologies, and the A logo are trademarks of Avago Technologies in the United States and other countries. Data subject to change. Copyright © 2005-2014 Avago Technologies. All rights reserved. Obsoletes AV01-0264EN AV02-0176EN - November 18, 2014

