

## 阅读申明

- 1.本站收集的数据手册和产品资料都来自互联网，版权归原作者所有。如读者和版权方有任何异议请及时告之，我们将妥善解决。
- 2.本站提供的中文数据手册是英文数据手册的中文翻译，其目的是协助用户阅读，该译文无法自动跟随原稿更新，同时也可能存在翻译上的不当。建议读者以英文原稿为参考以便获得更精准的信息。
- 3.本站提供的产品资料，来自厂商的技术支持或者使用者的心得体会等，其内容可能存在描述上的差异，建议读者做出适当判断。
- 4.如需与我们联系，请发邮件到marketing@iczoom.com，主题请标有“数据手册”字样。

## Read Statement

1. The datasheets and other product information on the site are all from network reference or other public materials, and the copyright belongs to the original author and original published source. If readers and copyright owners have any objections, please contact us and we will deal with it in a timely manner.
2. The Chinese datasheets provided on the website is a Chinese translation of the English datasheets. Its purpose is for reader's learning exchange only and do not involve commercial purposes. The translation cannot be automatically updated with the original manuscript, and there may also be improper translations. Readers are advised to use the English manuscript as a reference for more accurate information.
3. All product information provided on the website refer to solutions from manufacturers' technical support or users the contents may have differences in description, and readers are advised to take the original article as the standard.
4. If you have any questions, please contact us at marketing@iczoom.com and mark the subject with "Datasheets" .

**MESSRS :**

---

## Product Drawing

---

**CUSTOMER'S PRODUCT NAME:**

---

**TDK PRODUCT NAME: DC/AC INVERTER UNIT CXA- P1012B-NJL**

---

**TENTATIVE**

**\*Notice**

Product Drawing is not contract. This is only technical data.

This technical data may change internal description without any notice.

When you design final product please request us specification through our sales or distributors.

After you receive the specification, the contract is effective on signature of the specification.



**TDK-Lambda Corporation**

PREPARED BY	APPROVED BY	AUTHORIZED BY
<i>April 16, 2010 M.Tsujsaka</i>	<i>April 16, 2010 K.Yamaishi</i>	<i>April 16, 2010 H.Masuoka</i>

DWG.No.

CTR-3833-X

## Precautionary Notes Regarding the Use of This Inverter

**When using this product, give due consideration to the precautionary notes described below and ensure a safe design. Inappropriate use may result in electric shock, injury or fire.**

### ⚠ Warning



- This product is subject to high voltage. Do not touch it while the power is on. Failing to do so may result in electric shock.

### ⚠ Caution

- This product is designed for lighting Cold Cathode Fluorescent Lamps. Do not use it with any other load.
- Store this product under the conditions defined in the specification document.
- Do not store this product in an environment where dust, dirt or corrosive gas (salt, acid, base, etc.) is present.
- This product is subject to high voltage. If there is a possibility that the user may touch the product, provide a proper warning indication in order to draw the user's attention.
- This product is designed for use with general electronic equipment. If it is to be used with medical equipment that directly affects human life or for the control of transportation equipment to which passengers entrust their lives, provide thorough fail-safe measures.
- Consult us before using if this product is to be installed in a habitual vibration environment (vehicle, etc.).
- Avoid using this product under high temperatures or high humidity or in an environment in which dust, dirt or any corrosive gas (salt, acid, base, etc.) is present. Also, be careful not to allow the formation of dew condensation. It may result in damage or electric shock.
- If the product does not have a built-in protective circuit (circuit breaker, fuse, etc.), it is recommended that a fuse be used at the input stage to prevent the generation of smoke or fire in the event of a malfunction. Even when the product has a built-in protective circuit (circuit breaker, fuse, etc.), the circuit may not function properly due to inappropriate operating conditions or power-supply capacity. It is recommended that an appropriate protective circuit (circuit breaker, fuse, etc.) be provided separately from the built-in circuit.
- Use the product only within the specified input voltage, output power, output voltage and operating temperature ranges. Exceeding these values may result in damage, etc.
- Provide a measure for the prevention of surge voltage due to lightning, etc. Abnormal voltage may result in damage, etc.
- To prevent problems from occurring as a result of a short circuit in the high voltage section, be sure to take appropriate measures to prevent the entry of foreign substances into the inverter after it is installed.
- This product is not designed to provide resistance to radiation.
- In order to protect the inverter from vibration and shock, be sure to use all the mounting holes when installing the inverter.
- Ripples could be superimposed on the voltage and the current in the input source connected to the inverter, depending on the impedance in the input source, wiring, etc. When you select an input source, please check waveforms, etc on the final set.
- Please use all the mounting holes, because to defend the converter from vibration and impact.

### Handling Precautions

- This product uses thin wires. Observe the following precautions and handle it with care so as not to cause wire breakage. Broken wire may result in damage, etc.
  - ❖ Do not stack multiple products on top of one another.
  - ❖ Do not allow the product to come in contact with tools, etc.
- Do not apply excessive stress during installation. It may cause chipping and cracking, resulting in damage, etc.
- Provide clearance between the high-voltage section of this product and the frame body on which the product is installed and also the conductor section as on page 2, [1] "Outline".
- Do not use the product after it has been dropped because there is the possibility that components have been damaged.

	No.	MATERIALS NAME	QU	MATERIAL	REMARK	
	PRODUCT NAME or MODEL, TITLE					
	DC-AC INVERTER UNIT CXA-P1012B-NJL					
<b>TDK-Lambda</b>	NAME OF DRAWING			DRAWING No.	PAGE	
	Product Drawing			CTR-3833-X	1	

1. Part Name

The part name is CXA-P1012B-NJL.

2. Contents

Item	Atatched view	Page
1.Appearance,Structure and Dimensions		
Outline	refer to [1]	3
Pin configration	refer to [1]	4
2.Characteristics		
Absolute Maximum Ratings	refer to [2]	5
3.Electrical Characteristics	refer to [3]	5
4.Start up and operating condition	refer to [4]	5
5.Test circuit	refer to [4]	6
6.Reliability Test	refer to [5]	7
7.Packing and Marking	refer to [6]	8
8.Others		
Test Cond Std Warranty Others	refer to [7]	8

No.	MATERIALS NAME	QU	MATERIAL	REMARK
PRODUCT NAME or MODEL,TITLE				
DC-AC INVERTER UNIT CXA-P1012B-NJL				
NAME OF DRAWING		DRAWING No.		PAGE
Product Drawing		CTR-3833-X		2

**TDK-Lambda**

**\*If product drawing is different from product specification, product specification is prior.**

●Features●

- This inverter is for two lamps.
  - The high-voltage area (terminals and patterns) is coated with silicone so as to avoid the defects caused by dust.
  - This product is conformity to RoHS directive. ( ※ )
- ( ※ ) Conformity to RoHS Directive: This means that, in conformity with EU Directive 2002/95/EC, lead, cadmium, hexavalent chromium, and specific bromine-based flame retardants, PBB and PBDE, have not been used, except for exempted applications.

[1] Outline  
1-1. Outline

Top View

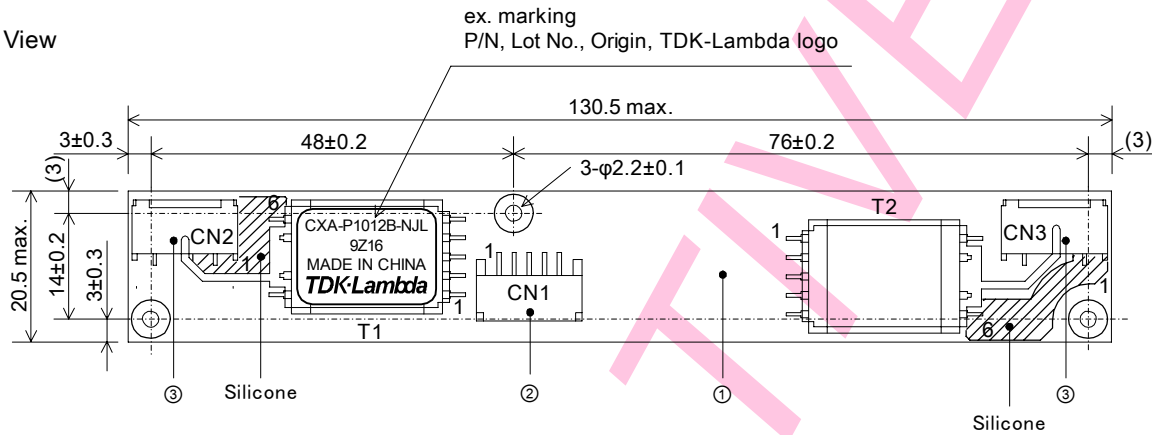

Side View

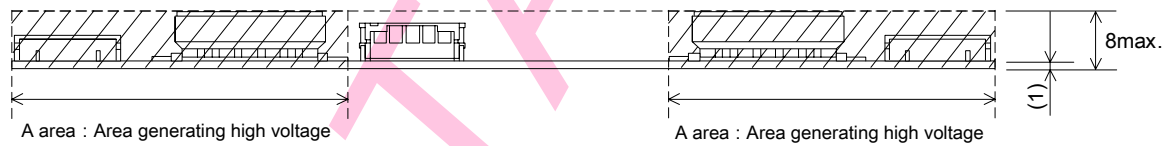

※Please secure 3mm or longer space distance from the high voltage generating area in all directions. Please see Note 1-4 for the details.

Bottom View

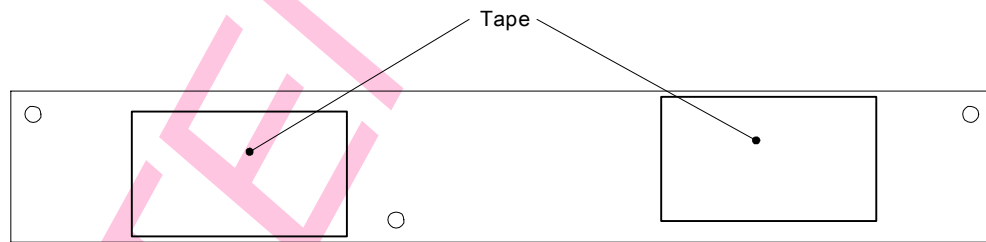

Unit:mm  
Mass:21.0g typ.

The dimensional deviation not instructed is assumed to be ±0.3mm

No.	Part Description	Material	Qu	Remark	Mates With
①	PCB	Composite (CEM-3)	1	UL94V-0 t=1.0	-
②	Input Connector CN1	S5B-PH-SM4-TB(LF)(SN)	1	JST	PHR-5
③	Output Connector CN2,CN3	SM02(8.0)B-BHS-1-TB(LF)(SN)	2	JST	BHR-03VS-1

No.	MATERIALS NAME	QU	MATERIAL	REMARK
PRODUCT NAME or MODEL,TITLE				
DC-AC INVERTER UNIT CXA-P1012B-NJL				
NAME OF DRAWING		DRAWING No.		PAGE
Product Drawing		CTR-3833-X		3

**TDK-Lambda**

1-2. Connector Configuration

Input side CN1

Pin No.	Symbols	Ratings	Notes
CN1-1	Vin	12V	Input Voltage
CN1-2	GND	0V	GND
CN1-3 CN1-4 CN1-5	N.C.	-	-

Output side CN2,3

Pin No.		Symbols	Ratings	Notes
CN2-1	CN3-1	VHIGH1,2	5mAmps	Output1,2
CN2-2	CN3-2	N.C.	-	-
CN2-3	CN3-3	VLOW1,2	(2V)	Output1,2 Return

Note1-1. The output is floating.  
Both CN2-1, CN2-3, CN3-1, and CN3-3 be come high voltages.

Note1-2. Marking of TDK part No, Date code, Country of origin.  
1) TDK part No., Date code, Country of origin, TDK-Lambda Logo, is marked on the transformer.  
2) Date code example. (ex. Dec. 16. 2009)

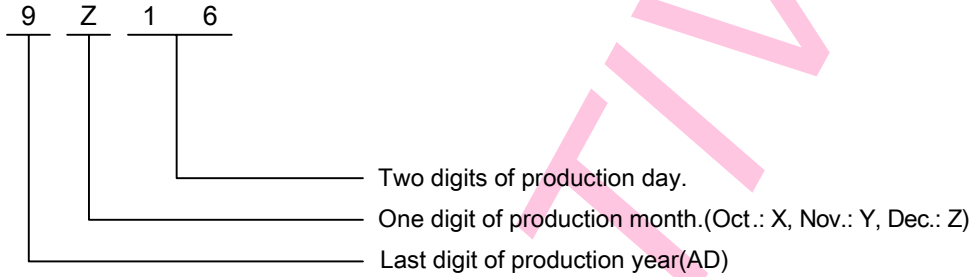

3) Country of origin code example. (ex. MADE IN JAPAN. MADE IN CHINA,MADE IN MALAYSIA).

Note1-3. For circuit connection, please prefer to test circuit diagram [4].

Note1-4. Please use minimum of 3mm clearance (all directions) between inverter high voltage area and any conductors. Please refer to mechanical drawing for marking of high voltage area.

Note1-5. Open voltage (strike voltage) is measured across the transformer secondary winding at no load as the reading at the output connector would be less than the actual value.

Note1-6. Mounting hole of part b is located near a high voltage pattern layout.  
To avoid electrocution, use a non-conductive screw, or create an assembly that will electrically insulate the mounting screw.

Note1-7. If the start up voltage falls below Cold Cathode Tube strike voltage, the CCFL will not light up easily specially at lower ambient temperature. Please review mounting instruction to avoid any abnormal operation due to coupling/leakage capacitance of inverter high voltage area to any surrounding conductor.

Fig1.High Voltage Code

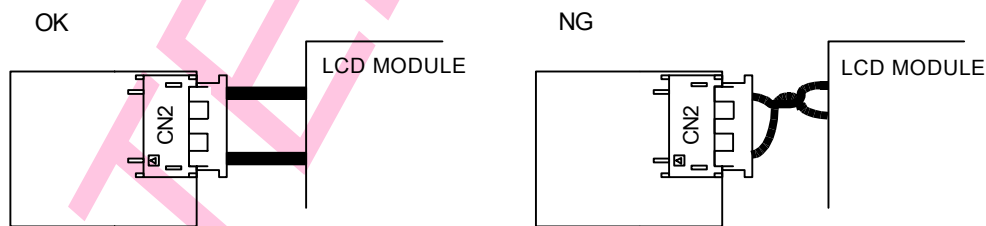

Note1-8. Please check your lamp characteristic for minimum operational current and set the limit point in your design to avoid flickering and/or abnormal operation.

Note1-9. For proper operation of circuit protection (fuse or IC PROTECTOR),Please use minimum of 2.0A capacity for input power supply.

Note1-10. Impedence from the wire connection can cause a ripple in the input. The product has an internal fuse of 1.0A. Please check that input current peak wave form does not exceed 1.0A.

No.	MATERIALS NAME	QU	MATERIAL	REMARK
PRODUCT NAME or MODEL,TITLE				
DC-AC INVERTER UNIT CXA-P1012B-NJL				
TDK-Lambda	NAME OF DRAWING		DRAWING No.	PAGE
	Product Drawing		CTR-3833-X	4

[2] Absolute maximum ratings

Items	Symbols	Specification	Unit	Notes
Input Voltage	Vin	0 ~ 14.4	V	A maximum wet ball temperature is 38°C No dew.
Load Resistance	Pout	9	W	
Operating Temp. range	Ta	-20 ~ 70	°C	
Storage Temp. range	Ts	-30 ~ 85		
Humidity range	RH	95	%RH	

[3] Electrical specifications

Items	Symbols	Specification			Unit			Notes	Notes
		Vin(V)	Ta(°C)	RL1,2(kΩ)	MIN.	TYP.	MAX.		
Output Current	Iout1/ Iout2	12±0.12	18 ~ 28	120	4.5	5	5.5	mArms	
Output Current	Iout1/ Iout2	12±0.6	-20 ~ 70	120	4	5	6		
Input Current	Iin	12±0.6	-20 ~ 70	120	-	0.62	0.9	A	
Frequency	F	12±0.6	-20 ~ 70	120	30	37	44	kHz	
Open Circuit Voltage	Vopen	11.4MIN	-20 ~ 70	∞	1400	1500	-	Vrms	※3-1

Note3-1. Please shut and measure SW. For SW, please refer to test circuit diagram [5].

[4] Start up and operating condition

Schematic Diagram

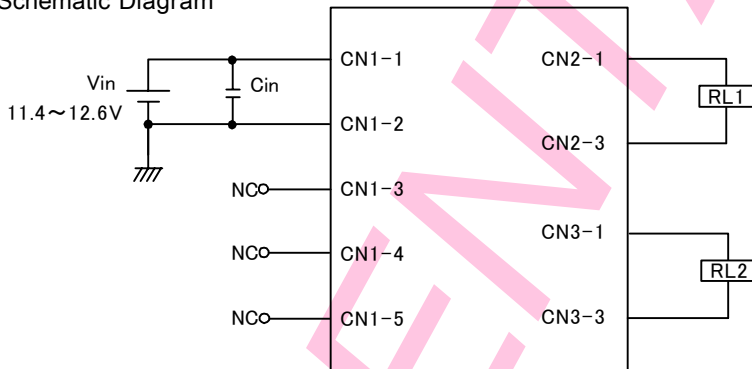

Rise Time

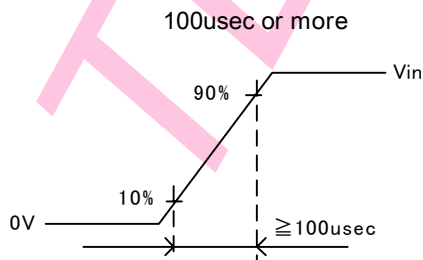

Input Capacitor Cin

As for this product, the capacitor is not inserted in the input. Addition of external capacitors is recommended.

No.	MATERIALS NAME	QU	MATERIAL	REMARK
PRODUCT NAME or MODEL, TITLE				
DC-AC INVERTER UNIT CXA-P1012B-NJL				
NAME OF DRAWING			DRAWING No.	PAGE
Product Drawing			CTR-3833-X	5

**TDK-Lambda**

[5] Test circuit

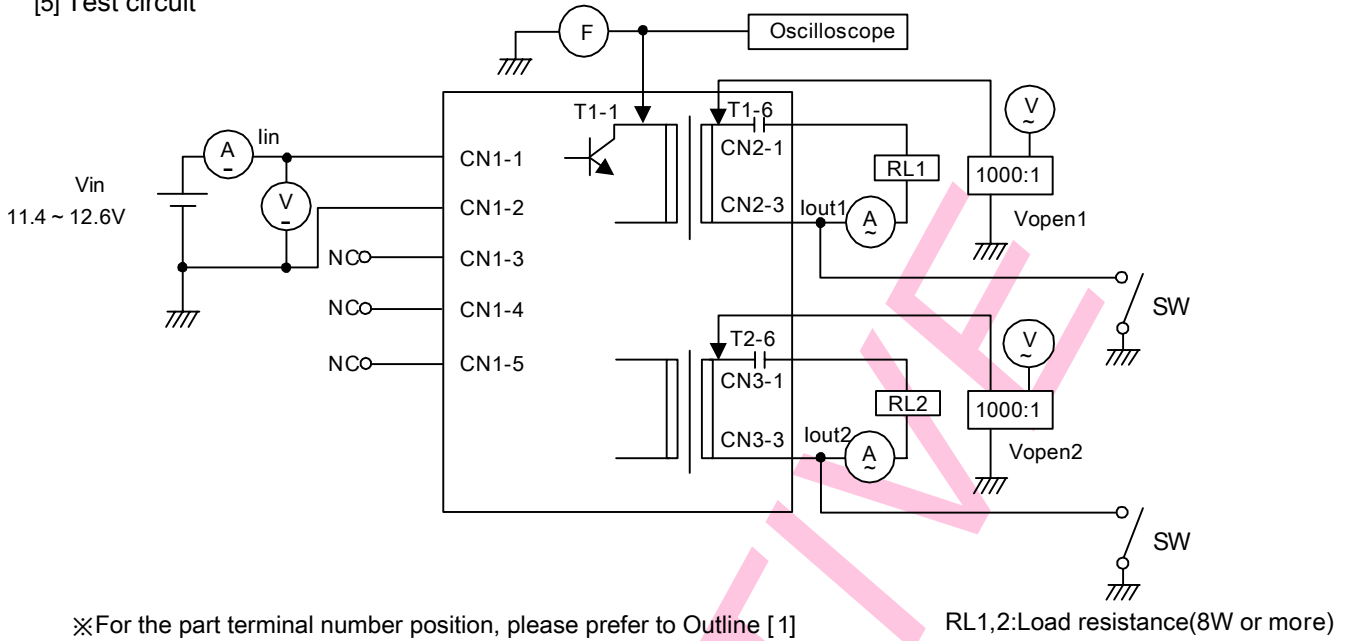

※For the part terminal number position, please refer to Outline [ 1]

RL1,2:Load resistance(8W or more)

Note5-1.Safety Function

- (V) Digital Multiple Meter(ADVA NTEST R6452A or equivalent)
- (A) DC Current Meter(ADVANTEST R6452A or equivalent)
- (V) True RMS Meter(NF Circuit M2170 or equivalent.)
- (F) Frequency Counter(ADVANTEST R6452A or equivalent)
- (A) High Frequency Current Meter(FLUKE 187 or equivalent)
- 1000:1 High Voltage Probe(Tektronix P6015A or equivalent)

LCD module Connected chart (reference)

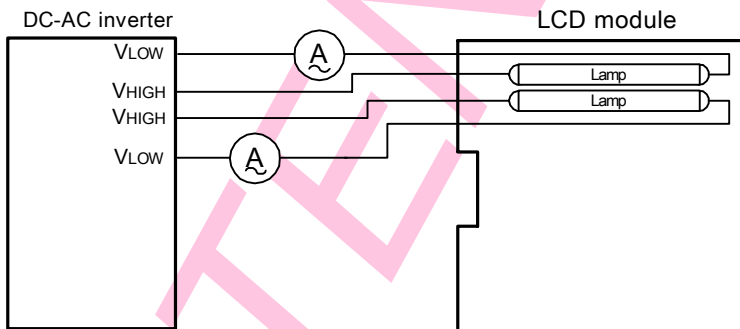

Connect the High Frequency Current Meter to the Low-Voltage (VLOW) side.

No.	MATERIALS NAME	QU	MATERIAL	REMARK
PRODUCT NAME or MODEL,TITLE				
DC-AC INVERTER UNIT CXA-P1012B-NJL				
NAME OF DRAWING			DRAWING No.	PAGE
Product Drawing			CTR-3833-X	6

**TDK-Lambda**



[6] Reliability test

Following test items are assured.

Items	Conditions	Judgement
Low Temp. Non operational	-40°C 500h	Electrical and apperance should be in the spec.
Low Temp.operational	-10°C 500h Load cond.:TYP	
High Temp. Non operational	85°C 500h	
High Temp.operational	60°C 500h Load cond.:TYP	
Heat shock	-20°C↔75°C 30min.Each 100 Cycles	
Humidity (Non operational)	40°C 90 ~ 95%RH 500h	
Vibration	10 ~ 55Hz Amplitude 0.35mm or 49m/s <sup>2</sup> Sweep:1分 30min each axis X,Y,Z	
Shock	980m/s <sup>2</sup> 6ms Harf-sine pulse 1 time each axis ±X,Y,Z	

TEMPERATURE

No.	MATERIALS NAME	QU	MATERIAL	REMARK
PRODUCT NAME or MODEL,TITLE				
DC-AC INVERTER UNIT CXA-P1012B-NJL				
<b>TDK-Lambda</b>	NAME OF DRAWING		DRAWING No.	PAGE
	Product Drawing		CTR-3833-X	7

[7] Packing and Marking

A shipping box is packaged to avoid from water or damage. Following items are printed on the box.

- 6-1. TDK part No. CXA-P1012B-NJL
- 6-2. Manufacture
- 6-3. QTY.

Several layers of Cardboard Sheet  
(to fill in space gap)  
:380×313×6 D

5 Layers Tray + ※Cover 1 Layer  
※For the top layer, place empty tray  
(without product inside)

Tray (Anti-Static)  
:PACK CXA-P1012B P  
(20 pcs) x 5 layers = 100 pcs / box  
\*Place one layer over the other in alternating position.  
\*Check that arrow mark (↑)indicator shows alternating position.

Outer Carton  
384 x 371 x 98  
Dimension  
(400mm:L) x (333mm:W) x (122mm:H)  
Gross Weight : Approximately 3.5kg

Bottom Cardboard Sheet  
380 x 313 x 6 D 2pcs.

Product Label  
Product Name  
Manufacturer  
Quantity

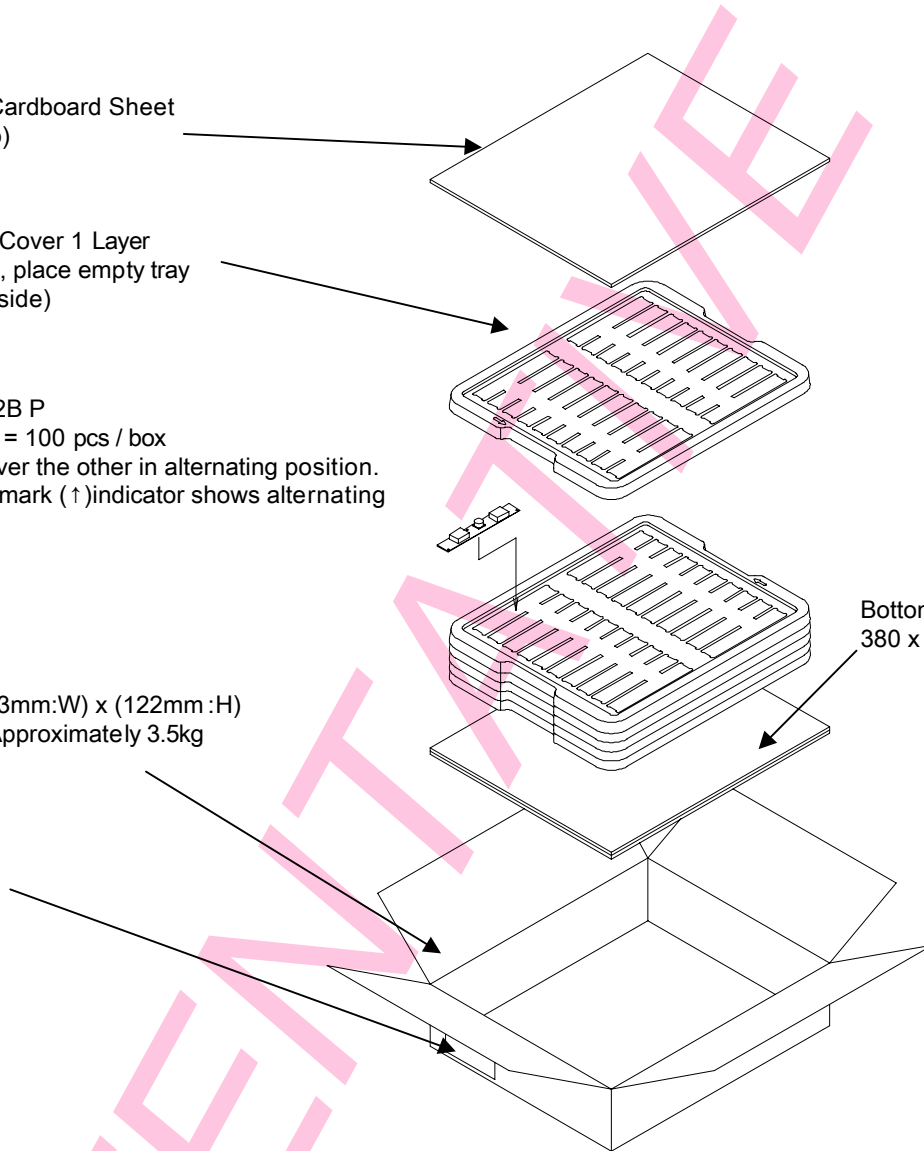

[8] Others

- 7-1. Test conditions  
Unless otherwise specified, the temperature to be (25±15)°C and humidity to be (65±20) %RH.
- 7-2. Warranty  
Warranty shall be for one year after delivery, and those products causing failure during the warranty period and which failures are attributed to the manufacturer's responsibility shall be replaced at no charge.
- 7-3. Others  
When any doubt arises about this specification, it shall be discussed and decided upon between both parties.

No.	MATERIALS NAME	QU	MATERIAL	REMARK
PRODUCT NAME or MODEL, TITLE				
DC-AC INVERTER UNIT CXA-P1012B-NJL				
<b>TDK-Lambda</b>	NAME OF DRAWING		DRAWING No.	PAGE
	Product Drawing		CTR-3833-X	8