

阅读申明

- 1.本站收集的数据手册和产品资料都来自互联网，版权归原作者所有。如读者和版权方有任何异议请及时告之，我们将妥善解决。
- 2.本站提供的中文数据手册是英文数据手册的中文翻译，其目的是协助用户阅读，该译文无法自动跟随原稿更新，同时也可能存在翻译上的不当。建议读者以英文原稿为参考以便获得更精准的信息。
- 3.本站提供的产品资料，来自厂商的技术支持或者使用者的心得体会等，其内容可能存在描述上的差异，建议读者做出适当判断。
- 4.如需与我们联系，请发邮件到marketing@iczoom.com，主题请标有“数据手册”字样。

Read Statement

1. The datasheets and other product information on the site are all from network reference or other public materials, and the copyright belongs to the original author and original published source. If readers and copyright owners have any objections, please contact us and we will deal with it in a timely manner.
2. The Chinese datasheets provided on the website is a Chinese translation of the English datasheets. Its purpose is for reader's learning exchange only and do not involve commercial purposes. The translation cannot be automatically updated with the original manuscript, and there may also be improper translations. Readers are advised to use the English manuscript as a reference for more accurate information.
3. All product information provided on the website refer to solutions from manufacturers' technical support or users the contents may have differences in description, and readers are advised to take the original article as the standard.
4. If you have any questions, please contact us at marketing@iczoom.com and mark the subject with "Datasheets" .



Precision Series KK - 2 Watt multiple element 1/4" shaft diameter



Precision series KK/2RV7 potentiometers are suitable for both military and commercial applications requiring multiple elements. They can easily be customized to meet special requirements.

FEATURES:

- hot molded carbon element
- gold-plated terminals
- stainless-steel shaft and housing
- quality meeting or exceeding MIL-R-94 - QPL listed

OPTIONS:

- custom shafts and bushings
- special tapers
- fourth (center) terminal
- concentric shafts
- attached switches

ELECTRICAL SPECIFICATIONS:

- Resistance range, linear taper:** 50 Ω to 5 Meg Ω
- Resistance range, logarithmic taper:** 150 Ω to 1 Meg Ω
- Resistance tolerance:** $\pm 10\%$ or $\pm 20\%$
- Resistance taper:** linear, logarithmic, reverse logarithmic;
other tapers by special order
- Power rating:** 2 watts at 70°C derated to 0 watts at 120°C
- Insulation resistance:**
dry: 10K Meg Ω
wet: 100K Meg Ω
- Dielectric strength:** 900 V RMS at sea level
- Operating voltage:** 500 V, subject to power rating

MECHANICAL SPECIFICATIONS:

- Mechanical rotation:** 314°
- Operating torque:** 1 oz/in to 12 oz/in
- Rotational life:** 25,000 cycles

ENVIRONMENTAL SPECIFICATIONS:

- Operating temperature:** - 65°C to +125°C
- Resistance to soldering heat:** 350°C for 5 seconds
- Humidity range:** per MIL-R-94
- Vibration range:** per MIL-R-94
- Shock resistance:** per MIL-R-94
- Load life:** 1000 hours at 70°C



DRAWING:

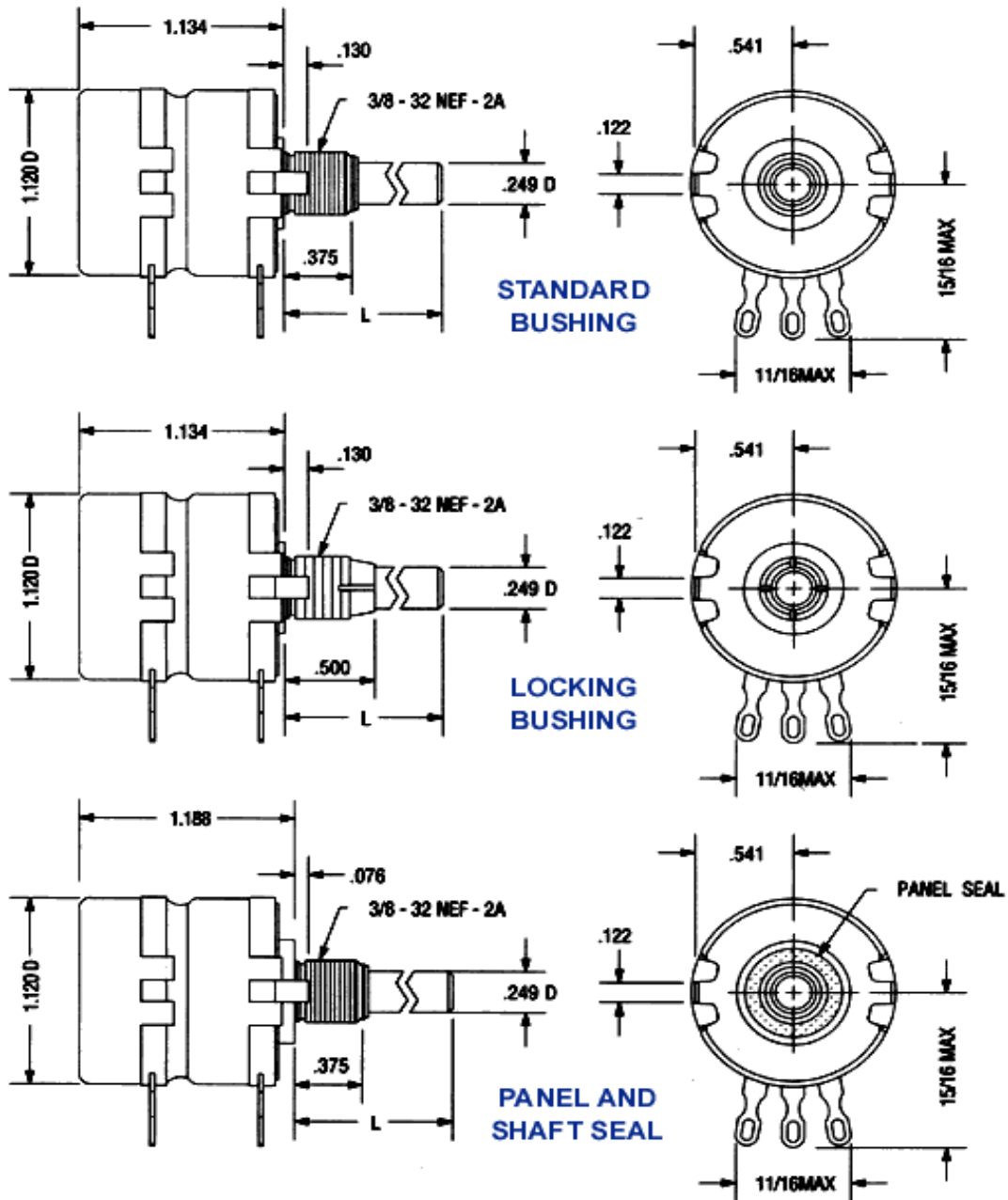



ORDERING INFORMATION:

Ordering Information - Commercial Part Numbers							
Series	Bushing	Switch	Taper	Resistance Value	Tolerance	Shaft Style	Shaft Length
KK = series KK - dual element KKK = series KKK - triple element	Blank = standard L = locking W = panel & shaft steel	Blank = without switch S = SPST switch	U = linear A = logarithmic B = reverse logarithmic	Total resistance value in Ω: first 2 digits significant, third digit = number of zeroes	1 = 10% of nominal 2 = 20% of nominal	R = round S = slotted F = flatted	16 = 1/2" 20 = 5/8" 24 = 3/4" 28 = 7/8" 32 = 1" 40 = 1 1/4" 48 = 1 1/2" 64 = 2" 80 = 2 1/2" 96 = 3"
Example: K KU1041S28 note: not all part number combinations are valid							

Ordering Information - Military Part Numbers						
Style	Bushing	Temperature & Moisture Characteristics	Shaft Style	Shaft Length	Resistance Value	Taper & Tolerance
2RV7 = MIL style 2RV7	N = standard L = locking S = panel & shaft steel	Y = as per MIL-R-94	S = slotted F = flatted	B = 1/2" A = 5/8" D = 7/8" G = 1 1/4" J = 2" K = 2 1/2"	Total resistance value in Ω: first 2 digits significant, third digit = number of zeroes	A = linear 10% B = linear 20% C = logarithmic 10% D = logarithmic 20% E = reverse logarithmic 10% F = reverse logarithmic 20%
Example: RV4NAYS B000A note: not all part number combinations are valid						