

阅读申明

- 1.本站收集的数据手册和产品资料都来自互联网，版权归原作者所有。如读者和版权方有任何异议请及时告之，我们将妥善解决。
- 2.本站提供的中文数据手册是英文数据手册的中文翻译，其目的是协助用户阅读，该译文无法自动跟随原稿更新，同时也可能存在翻译上的不当。建议读者以英文原稿为参考以便获得更精准的信息。
- 3.本站提供的产品资料，来自厂商的技术支持或者使用者的心得体会等，其内容可能存在描述上的差异，建议读者做出适当判断。
- 4.如需与我们联系，请发邮件到marketing@iczoom.com，主题请标有“数据手册”字样。

Read Statement

1. The datasheets and other product information on the site are all from network reference or other public materials, and the copyright belongs to the original author and original published source. If readers and copyright owners have any objections, please contact us and we will deal with it in a timely manner.
2. The Chinese datasheets provided on the website is a Chinese translation of the English datasheets. Its purpose is for reader's learning exchange only and do not involve commercial purposes. The translation cannot be automatically updated with the original manuscript, and there may also be improper translations. Readers are advised to use the English manuscript as a reference for more accurate information.
3. All product information provided on the website refer to solutions from manufacturers' technical support or users the contents may have differences in description, and readers are advised to take the original article as the standard.
4. If you have any questions, please contact us at marketing@iczoom.com and mark the subject with "Datasheets" .

Trimmer Potentiometers



Lead Sealed Type Single-turn PVC6/PV32/PV34 Series

PVC6 Series

■ Features

1. Enlarged and colored rotor provides superior adjustability.
2. Cone-shaped rotor improves driver insertion during automatic adjustment.
3. Available for "Zero" plus adjustment tool (taper head) use
4. Easy to see 11-scales adjustment positions.
5. Sealed construction protects the interior from dust and liquid, which achieves stable performance.
6. Available for ultrasonic cleaning after soldering
7. During cutting process by the inserter machine, the round shaped lead wire prevents clinch problems and realizes longer life of cutter than flat shaped lead wire.
8. Flammability: UL94V-0
9. To be complied with RoHS directive by new Cd free cermet resistive material. Pb free terminals with Sn plating.

■ Applications

- | | |
|-----------------|-------------------------|
| 1. DY | 2. CRT display |
| 3. Power supply | 4. Professional cameras |
| 5. CATV | 6. FAX |
| 7. Printers | 8. OA Equipment |
| 9. Sensors | |



PVC6A

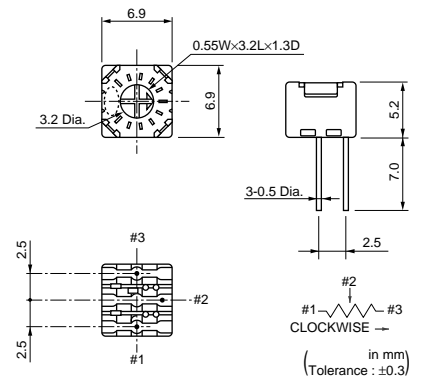

PVC6D

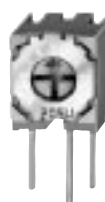
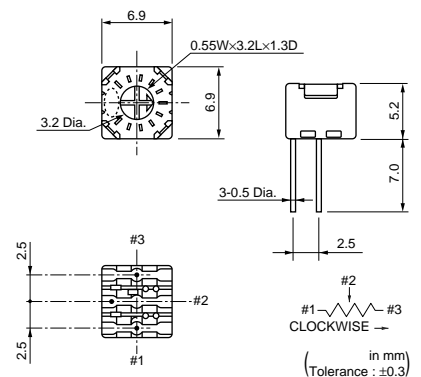

PVC6E

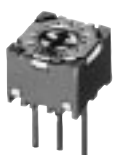
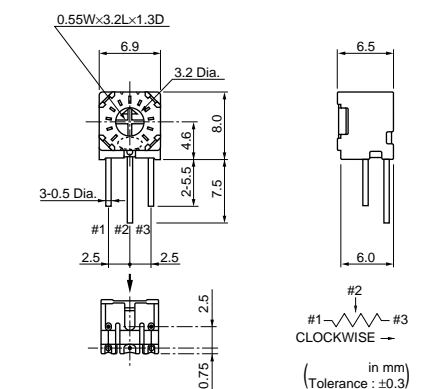

PVC6M

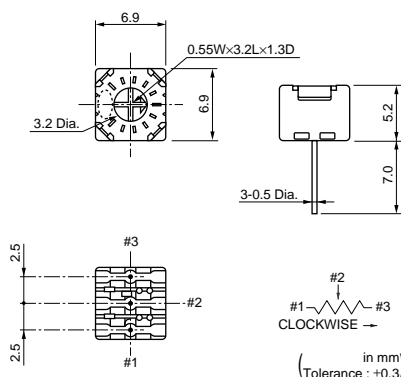

PVC6H

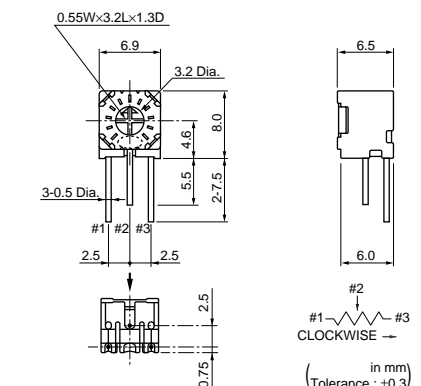

Continued on the following page.

Continued from the preceding page.

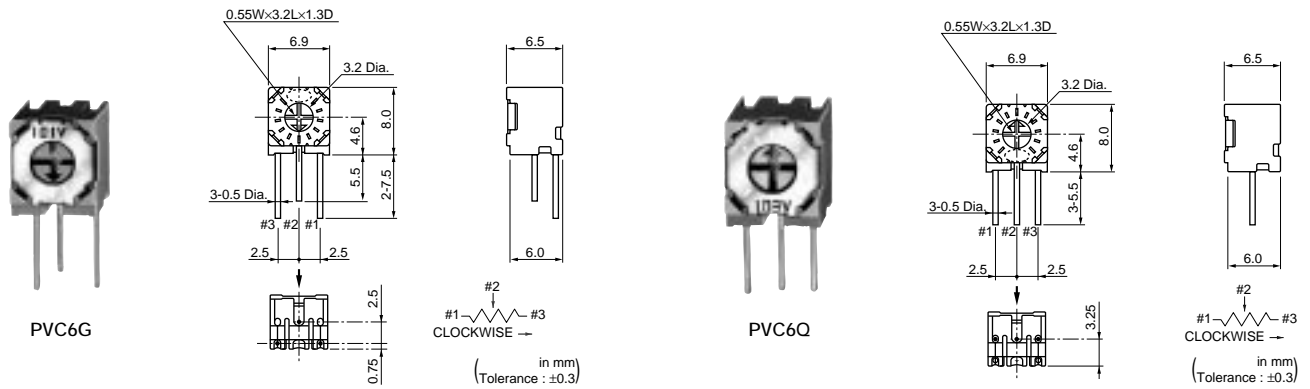

Part Number	Power Rating	Soldering Method	Number of Turns (Effective Rotation Angle)	Total Resistance Value	TCR
PVC6□100C01	0.5W(70°C)	Flow/Soldering Iron	1(240°±5°)	10ohm ±10%	±100ppm/°C
PVC6□200C01	0.5W(70°C)	Flow/Soldering Iron	1(240°±5°)	20ohm ±10%	±100ppm/°C
PVC6□250C01	0.5W(70°C)	Flow/Soldering Iron	1(240°±5°)	25ohm ±10%	±100ppm/°C
PVC6□500C01	0.5W(70°C)	Flow/Soldering Iron	1(240°±5°)	50ohm ±10%	±100ppm/°C
PVC6□101C01	0.5W(70°C)	Flow/Soldering Iron	1(240°±5°)	100ohm ±10%	±100ppm/°C
PVC6□201C01	0.5W(70°C)	Flow/Soldering Iron	1(240°±5°)	200ohm ±10%	±100ppm/°C
PVC6□251C01	0.5W(70°C)	Flow/Soldering Iron	1(240°±5°)	250ohm ±10%	±100ppm/°C
PVC6□501C01	0.5W(70°C)	Flow/Soldering Iron	1(240°±5°)	500ohm ±10%	±100ppm/°C
PVC6□102C01	0.5W(70°C)	Flow/Soldering Iron	1(240°±5°)	1k ohm ±10%	±100ppm/°C
PVC6□202C01	0.5W(70°C)	Flow/Soldering Iron	1(240°±5°)	2k ohm ±10%	±100ppm/°C
PVC6□252C01	0.5W(70°C)	Flow/Soldering Iron	1(240°±5°)	2.5k ohm ±10%	±100ppm/°C
PVC6□502C01	0.5W(70°C)	Flow/Soldering Iron	1(240°±5°)	5k ohm ±10%	±100ppm/°C
PVC6□103C01	0.5W(70°C)	Flow/Soldering Iron	1(240°±5°)	10k ohm ±10%	±100ppm/°C
PVC6□203C01	0.5W(70°C)	Flow/Soldering Iron	1(240°±5°)	20k ohm ±10%	±100ppm/°C
PVC6□253C01	0.5W(70°C)	Flow/Soldering Iron	1(240°±5°)	25k ohm ±10%	±100ppm/°C
PVC6□503C01	0.5W(70°C)	Flow/Soldering Iron	1(240°±5°)	50k ohm ±10%	±100ppm/°C
PVC6□104C01	0.5W(70°C)	Flow/Soldering Iron	1(240°±5°)	100k ohm ±10%	±100ppm/°C
PVC6□204C01	0.5W(70°C)	Flow/Soldering Iron	1(240°±5°)	200k ohm ±10%	±100ppm/°C
PVC6□254C01	0.5W(70°C)	Flow/Soldering Iron	1(240°±5°)	250k ohm ±10%	±100ppm/°C
PVC6□504C01	0.5W(70°C)	Flow/Soldering Iron	1(240°±5°)	500k ohm ±10%	±100ppm/°C
PVC6□105C01	0.5W(70°C)	Flow/Soldering Iron	1(240°±5°)	1M ohm ±10%	±100ppm/°C
PVC6□205C01	0.5W(70°C)	Flow/Soldering Iron	1(240°±5°)	2M ohm ±10%	±100ppm/°C
PVC6□505C01	0.5W(70°C)	Flow/Soldering Iron	1(240°±5°)	5M ohm ±10%	±100ppm/°C
PVC6□100C04	0.5W(70°C)	Flow/Soldering Iron	1(240°±5°)	10ohm ±10%	±100ppm/°C
PVC6□200C04	0.5W(70°C)	Flow/Soldering Iron	1(240°±5°)	20ohm ±10%	±100ppm/°C
PVC6□250C04	0.5W(70°C)	Flow/Soldering Iron	1(240°±5°)	25ohm ±10%	±100ppm/°C
PVC6□500C04	0.5W(70°C)	Flow/Soldering Iron	1(240°±5°)	50ohm ±10%	±100ppm/°C
PVC6□101C04	0.5W(70°C)	Flow/Soldering Iron	1(240°±5°)	100ohm ±10%	±100ppm/°C
PVC6□201C04	0.5W(70°C)	Flow/Soldering Iron	1(240°±5°)	200ohm ±10%	±100ppm/°C
PVC6□251C04	0.5W(70°C)	Flow/Soldering Iron	1(240°±5°)	250ohm ±10%	±100ppm/°C
PVC6□501C04	0.5W(70°C)	Flow/Soldering Iron	1(240°±5°)	500ohm ±10%	±100ppm/°C
PVC6□102C04	0.5W(70°C)	Flow/Soldering Iron	1(240°±5°)	1k ohm ±10%	±100ppm/°C
PVC6□202C04	0.5W(70°C)	Flow/Soldering Iron	1(240°±5°)	2k ohm ±10%	±100ppm/°C
PVC6□252C04	0.5W(70°C)	Flow/Soldering Iron	1(240°±5°)	2.5k ohm ±10%	±100ppm/°C
PVC6□502C04	0.5W(70°C)	Flow/Soldering Iron	1(240°±5°)	5k ohm ±10%	±100ppm/°C
PVC6□103C04	0.5W(70°C)	Flow/Soldering Iron	1(240°±5°)	10k ohm ±10%	±100ppm/°C
PVC6□203C04	0.5W(70°C)	Flow/Soldering Iron	1(240°±5°)	20k ohm ±10%	±100ppm/°C
PVC6□253C04	0.5W(70°C)	Flow/Soldering Iron	1(240°±5°)	25k ohm ±10%	±100ppm/°C
PVC6□503C04	0.5W(70°C)	Flow/Soldering Iron	1(240°±5°)	50k ohm ±10%	±100ppm/°C
PVC6□104C04	0.5W(70°C)	Flow/Soldering Iron	1(240°±5°)	100k ohm ±10%	±100ppm/°C
PVC6□204C04	0.5W(70°C)	Flow/Soldering Iron	1(240°±5°)	200k ohm ±10%	±100ppm/°C
PVC6□254C04	0.5W(70°C)	Flow/Soldering Iron	1(240°±5°)	250k ohm ±10%	±100ppm/°C
PVC6□504C04	0.5W(70°C)	Flow/Soldering Iron	1(240°±5°)	500k ohm ±10%	±100ppm/°C
PVC6□105C04	0.5W(70°C)	Flow/Soldering Iron	1(240°±5°)	1M ohm ±10%	±100ppm/°C

Continued on the following page. ↗

Continued from the preceding page.

Part Number	Power Rating	Soldering Method	Number of Turns (Effective Rotation Angle)	Total Resistance Value	TCR
PVC6□205C04	0.5W(70°C)	Flow/Soldering Iron	1(240°±5°)	2M ohm ±10%	±100ppm/°C
PVC6□505C04	0.5W(70°C)	Flow/Soldering Iron	1(240°±5°)	5M ohm ±10%	±100ppm/°C

Operating Temperature Range: -55 to 125 °C

The blank column is filled with the code of adjustment direction and lead type (A, D, E, G, H, M and Q).

The order quantity should be an integral multiple of the "Minimum Quantity" .

The last three digits express the individual specification codes. C01 for standard type and C04 for radial taping type (PVC6M/PVC6Q series only).

Part Number	Power Rating (W)	Soldering Method	Number of Turns (Effective Rotation Angle)	Total Resistance Value	TCR (ppm/°C)	Remarks
PVC6□100A01	0.5(70°C)	Flow/Soldering Iron	1(240°±5°)	10 ohm±10%	±100	Non Standard Product (Cd Free)
PVC6□200A01	0.5(70°C)	Flow/Soldering Iron	1(240°±5°)	20 ohm±10%	±100	
PVC6□250A01	0.5(70°C)	Flow/Soldering Iron	1(240°±5°)	25 ohm±10%	±100	
PVC6□500A01	0.5(70°C)	Flow/Soldering Iron	1(240°±5°)	50 ohm±10%	±100	
PVC6□101A01	0.5(70°C)	Flow/Soldering Iron	1(240°±5°)	100 ohm±10%	±100	
PVC6□201A01	0.5(70°C)	Flow/Soldering Iron	1(240°±5°)	200 ohm±10%	±100	
PVC6□251A01	0.5(70°C)	Flow/Soldering Iron	1(240°±5°)	250 ohm±10%	±100	
PVC6□501A01	0.5(70°C)	Flow/Soldering Iron	1(240°±5°)	500 ohm±10%	±100	
PVC6□102A01	0.5(70°C)	Flow/Soldering Iron	1(240°±5°)	1k ohm±10%	±100	Non Standard Product (Cd included)
PVC6□202A01	0.5(70°C)	Flow/Soldering Iron	1(240°±5°)	2k ohm±10%	±100	
PVC6□252A01	0.5(70°C)	Flow/Soldering Iron	1(240°±5°)	2.5k ohm±10%	±100	
PVC6□502A01	0.5(70°C)	Flow/Soldering Iron	1(240°±5°)	5k ohm±10%	±100	
PVC6□103A01	0.5(70°C)	Flow/Soldering Iron	1(240°±5°)	10k ohm±10%	±100	
PVC6□203A01	0.5(70°C)	Flow/Soldering Iron	1(240°±5°)	20k ohm±10%	±100	
PVC6□253A01	0.5(70°C)	Flow/Soldering Iron	1(240°±5°)	25k ohm±10%	±100	
PVC6□503A01	0.5(70°C)	Flow/Soldering Iron	1(240°±5°)	50k ohm±10%	±100	
PVC6□104A01	0.5(70°C)	Flow/Soldering Iron	1(240°±5°)	100k ohm±10%	±100	
PVC6□204A01	0.5(70°C)	Flow/Soldering Iron	1(240°±5°)	200k ohm±10%	±100	
PVC6□254A01	0.5(70°C)	Flow/Soldering Iron	1(240°±5°)	250k ohm±10%	±100	
PVC6□504A01	0.5(70°C)	Flow/Soldering Iron	1(240°±5°)	500k ohm±10%	±100	
PVC6□105A01	0.5(70°C)	Flow/Soldering Iron	1(240°±5°)	1M ohm±10%	±100	
PVC6□205A01	0.5(70°C)	Flow/Soldering Iron	1(240°±5°)	2M ohm±10%	±100	
PVC6□505A01	0.5(70°C)	Flow/Soldering Iron	1(240°±5°)	5M ohm±10%	±100	
PVC6□100A04	0.5(70°C)	Flow/Soldering Iron	1(240°±5°)	10 ohm±10%	±100	
PVC6□200A04	0.5(70°C)	Flow/Soldering Iron	1(240°±5°)	20 ohm±10%	±100	
PVC6□250A04	0.5(70°C)	Flow/Soldering Iron	1(240°±5°)	25 ohm±10%	±100	
PVC6□500A04	0.5(70°C)	Flow/Soldering Iron	1(240°±5°)	50 ohm±10%	±100	
PVC6□101A04	0.5(70°C)	Flow/Soldering Iron	1(240°±5°)	100 ohm±10%	±100	
PVC6□201A04	0.5(70°C)	Flow/Soldering Iron	1(240°±5°)	200 ohm±10%	±100	
PVC6□251A04	0.5(70°C)	Flow/Soldering Iron	1(240°±5°)	250 ohm±10%	±100	
PVC6□501A04	0.5(70°C)	Flow/Soldering Iron	1(240°±5°)	500 ohm±10%	±100	
PVC6□102A04	0.5(70°C)	Flow/Soldering Iron	1(240°±5°)	1k ohm±10%	±100	Non Standard Product (Cd included)
PVC6□202A04	0.5(70°C)	Flow/Soldering Iron	1(240°±5°)	2k ohm±10%	±100	
PVC6□252A04	0.5(70°C)	Flow/Soldering Iron	1(240°±5°)	2.5k ohm±10%	±100	
PVC6□502A04	0.5(70°C)	Flow/Soldering Iron	1(240°±5°)	5k ohm±10%	±100	
PVC6□103A04	0.5(70°C)	Flow/Soldering Iron	1(240°±5°)	10k ohm±10%	±100	
PVC6□203A04	0.5(70°C)	Flow/Soldering Iron	1(240°±5°)	20k ohm±10%	±100	
PVC6□253A04	0.5(70°C)	Flow/Soldering Iron	1(240°±5°)	25k ohm±10%	±100	
PVC6□503A04	0.5(70°C)	Flow/Soldering Iron	1(240°±5°)	50k ohm±10%	±100	
PVC6□104A04	0.5(70°C)	Flow/Soldering Iron	1(240°±5°)	100k ohm±10%	±100	
PVC6□204A04	0.5(70°C)	Flow/Soldering Iron	1(240°±5°)	200k ohm±10%	±100	
PVC6□254A04	0.5(70°C)	Flow/Soldering Iron	1(240°±5°)	250k ohm±10%	±100	
PVC6□504A04	0.5(70°C)	Flow/Soldering Iron	1(240°±5°)	500k ohm±10%	±100	
PVC6□105A04	0.5(70°C)	Flow/Soldering Iron	1(240°±5°)	1M ohm±10%	±100	
PVC6□205A04	0.5(70°C)	Flow/Soldering Iron	1(240°±5°)	2M ohm±10%	±100	
PVC6□505A04	0.5(70°C)	Flow/Soldering Iron	1(240°±5°)	5M ohm±10%	±100	

Continued on the following page. ↗

Continued from the preceding page.

■ Construction

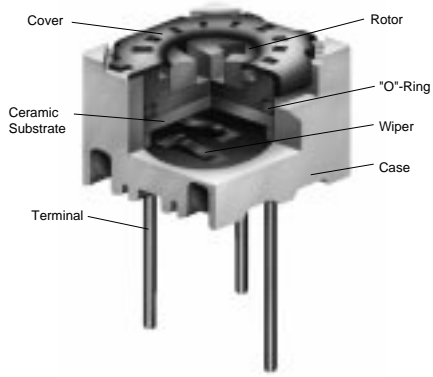

■ Mounting Holes

PVC6A/PVC6E

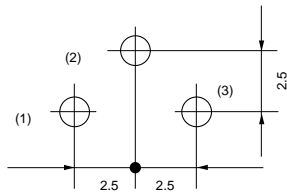

(Tolerance:±0.1 in mm)

PVC6D/PVC6H

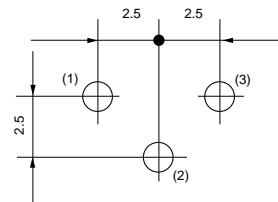

(Tolerance:±0.1 in mm)

PVC6M/PVC6Q

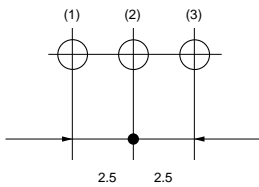

(Tolerance:±0.1 in mm)

PVC6G

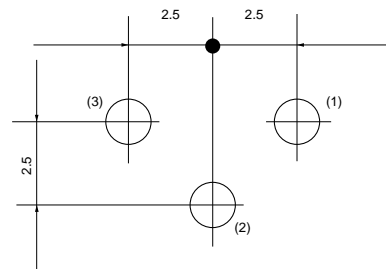

(Tolerance:±0.1 in mm)

Continued on the following page. ↗

☐ Continued from the preceding page.

■ Characteristics

Temperature Cycle	ΔTR	$\pm 2\%$
	$\Delta V.S.S.$	$\pm 1\%$
Humidity	ΔTR	$\pm 2\%$
	$\Delta V.S.S.$	$\pm 1\%$
	IR	100Mohm min.
Vibration (20G)	ΔTR	$\pm 1\%$
	$\Delta V.S.S.$	$\pm 1\%$
Shock (100G)	ΔTR	$\pm 1\%$
	$\Delta V.S.S.$	$\pm 1\%$
Temperature Load Life	ΔTR	$\pm 2\%$
	$\Delta V.S.S.$	$\pm 2\%$
Low Temperature Exposure	ΔTR	$\pm 2\%$
	$\Delta V.S.S.$	$\pm 1\%$
High Temperature Exposure	ΔTR	$\pm 2\%$
	$\Delta V.S.S.$	$\pm 1\%$
Rotational Life (200 cycles)	ΔTR	$\pm 4\%$

ΔTR : Total Resistance Change
 $\Delta V.S.S.$: Voltage Setting Stability
 IR : Insulation Resistance

PVC6/PV32/PV34 Series Notice

■ Notice (Operating and Storage Conditions)

1. Store in temperatures of -10 to +40 deg. C and relative humidity of 30-85%RH.
2. Do not store in or near corrosive gases.
3. Use within six months after delivery.
4. Open the package just before using.
5. Do not store under direct sunlight.
6. If you use the trimmer potentiometer in an environment other than listed below, please consult with a Murata factory representative prior to using.
The trimmer potentiometer should not be used under

- the following environmental conditions:
- (1) Corrosive gaseous atmosphere
(Ex. Chlorine gas, Hydrogen sulfide gas, Ammonia gas, Sulfuric acid gas, Nitric oxide gas, etc.)
 - (2) In liquid
(Ex. Oil, Medical liquid, Organic solvent, etc.)
 - (3) Dusty / dirty atmosphere
 - (4) Direct sunlight
 - (5) Static voltage nor electric/magnetic fields
 - (6) Direct sea breeze
 - (7) Other variations of the above

■ Notice (Rating)

1. When using with partial load (rheostat), minimize the power depending on the resistance value.
2. The maximum input voltage to a trimmer potentiometer should not exceed $(P.R)^{1/2}$ or the maximum operating voltage, whichever is smaller.
3. The maximum input current to a trimmer potentiometer should not exceed $(P/R)^{1/2}$ or the allowable wiper current, whichever is smaller.

■ Notice (Soldering and Mounting)

1. Soldering

(1) Standard soldering condition

(a) Flow soldering :

- >Pre-heating temp. 80-100 deg. C
- >Soldering temp. 260 deg. C max.
- >Soldering time 3 sec. max.

(b) Soldering iron :

- >Temperature of tip 300 deg. C max.
- >Soldering time 3 sec. max.
- >Wattage of iron 40W max.

Before using other soldering conditions than those listed above, please consult with Murata factory representative prior to using. If the soldering conditions are not suitable, e.g., excessive time and/or excessive temperature, the trimmer potentiometer may deviate from the specified characteristics.

- (2) To minimize mechanical stress when adjusting, the trimmer potentiometer should be mounted onto PCB without gap.
 - (3) The soldering iron should not come in contact with the case of the trimmer potentiometer. If such contact does occur, the trimmer potentiometer may be damaged.
- #### 2. Mounting
- (1) Use PCB hole to meet the pin of the trimmer potentiometer. If the trimmer potentiometer installs into insufficient PCB hole, the

trimmer potentiometer may be damaged by mechanical stress.

- (2) Do not apply excessive force (preferably 9.8N (Ref.: 1kgf) max.), when the trimmer potentiometer is mounted to the PCB.

3. Cleaning

- (1) Isopropyl-alcohol and Ethyl-alcohol are applicable solvents for cleaning. If you use any other types of solvents, please consult with a Murata factory representative prior to using.
- (2) The total cleaning time by cold dipping, vapor and ultrasonic washing (conditions as below) method should be less than 3 minutes.
- (3) For ultra-sonic cleaning, the available condition is as follows.
 - >Power: 600W (67 liter) max.
 - >Frequency: 28kHz
 - >Temperature: Ambient temperature

Due to the ultra-sonic cleaning equipment's peculiar self-resonance point and that the cleaning compatibility usually depends on the jig construction and/or the cleaning condition such as the depth of immersion, please check the cleaning equipment to determine the suitable conditions.

If the trimmer potentiometer is cleaned by other conditions, the trimmer potentiometer may be damaged.

PVC6/PV32/PV34 Series Notice

■ Notice (Handling)

1. Use suitable screwdrivers that fit comfortably in driver slot. We recommend the screwdrivers below.

* Recommended screwdriver for manual adjustment

<PVC6 series>

VESSEL MFG. : NO.9000+0x30

(Murata P/N : KMDR150)

TORAY INDUSTRIES, INC. : SA-2225

(Murata P/N : KMDR070)

<PV32/34 series>

ENGINEER INC. : DA-40

(Murata P/N : KMDR180)

* Recommended screwdriver bit for automatic adjustment

<PVC6 series>

VESSEL MFG. : NO.CA-10

(Murata P/N : KMBT090)

TORAY INDUSTRIES, INC. : JB-2225

(Murata P/N : KMBT070)

We can supply the screwdrivers above.

If you place an order, please specify the Murata P/N.

2. Don't apply more than 9.8N (Ref.; 1kgf) of twist and stress after mounting onto PCB to prevent contact intermittence. If excessive force is applied, the trimmer potentiometer may not function.
3. When adjusting with an adjustment tool, the applied force to the adjustment screw should not exceed 4.9N (Ref.; 500gf). If excessive force is applied, the trimmer potentiometer may not function due to damage.
4. The rotational torque at the position of the adjustment range should not exceed the stop strength.
5. When using a lock paint to fix slot position, please use adhesive resin without chlorine or sulfur (Three-bond "1401 series").

■ Notice (Other)

1. Please make sure that your product has been evaluated and confirmed against your specifications when our product is mounted to your product.
2. Murata cannot guarantee trimmer potentiometer integrity when used under conditions other than those specified in this document.

SMD Sealed Type/Lead Sealed Type Specifications and Test Methods

The following describes trimmer potentiometer testing conducted by Murata Manufacturing Co., Ltd. in accordance with MIL-R-22097 (Military specification for variable resistors, non-wirewound) and MIL-STD-202 (Test methods for electronic and electrical component parts).

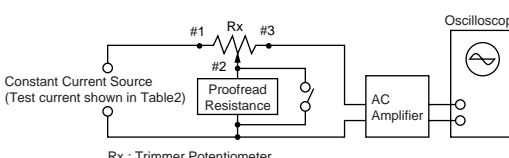
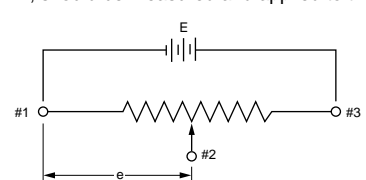
No.	Item	Test Methods																				
1	Total Resistance	<p>Measure total resistance between the resistance element and terminals (#1 and #3) with the contact arm positioned against a stop. The positioning of the contact arm and terminal should be the same for subsequent total resistance measurements on the same device. Use the test voltage specified in Table 1 for total resistance measurements. This voltage should be used for all subsequent total resistance measurements.</p> <table border="1" style="margin-left: auto; margin-right: auto; border-collapse: collapse;"> <thead> <tr style="background-color: #f2f2f2;"> <th>Total Resistance, Nominal (ohm)</th> <th>Maximum Test Voltage (V)</th> </tr> </thead> <tbody> <tr> <td>10 ≤ R ≤ 100</td> <td>1.0</td> </tr> <tr> <td>100 < R ≤ 1k</td> <td>3.0</td> </tr> <tr> <td>1k < R ≤ 10k</td> <td>10.0</td> </tr> <tr> <td>10k < R ≤ 100k</td> <td>30.0</td> </tr> <tr> <td>100k < R</td> <td>100.0</td> </tr> </tbody> </table> <p style="text-align: center;">Table 1: Total resistance test voltage</p>	Total Resistance, Nominal (ohm)	Maximum Test Voltage (V)	10 ≤ R ≤ 100	1.0	100 < R ≤ 1k	3.0	1k < R ≤ 10k	10.0	10k < R ≤ 100k	30.0	100k < R	100.0								
Total Resistance, Nominal (ohm)	Maximum Test Voltage (V)																					
10 ≤ R ≤ 100	1.0																					
100 < R ≤ 1k	3.0																					
1k < R ≤ 10k	10.0																					
10k < R ≤ 100k	30.0																					
100k < R	100.0																					
2	Residual Resistance	<p>Position the contact arm at the extreme counterclockwise limit of mechanical travel and measure the resistance between the contact arm and the corresponding end terminal. Then, position the contact arm at the extreme clockwise limit of mechanical travel and measure the resistance between the contact arm and the corresponding end terminal. During this test, take suitable precautions to ensure that the rated current of the resistance element is not exceeded.</p>																				
3	Contact Resistance Variation	<p>Contact resistance variation should be measured with the measuring circuit shown in Figure 1, or its equivalent. The adjustment rotor (screw) should be rotated in both directions through 90% of the actual effective-electrical rotational angle (number of turns) for a total of 6 cycles. Only the last 3 cycles should count in determining whether or not a contact resistance variation is observed at least twice in the same location, exclusive of the roll-on or roll-off points where the contact arm moves from the termination, on or off, the resistance element. The rate of rotation of the adjustment rotor (screw) should be such that the adjustment rotor (screw) completes 1 cycle for 5 seconds minimum to 2 minutes maximum. The test current used should follow the value given in Table 2 unless otherwise limited by power rating.</p> <table border="1" style="margin-left: auto; margin-right: auto; border-collapse: collapse;"> <thead> <tr style="background-color: #f2f2f2;"> <th>Standard Total Resistance R (ohm)</th> <th>Test Current</th> </tr> </thead> <tbody> <tr> <td>R ≤ 100</td> <td>20mA</td> </tr> <tr> <td>100 < R < 500</td> <td>10mA</td> </tr> <tr> <td>500 ≤ R < 1k</td> <td>4mA</td> </tr> <tr> <td>1k ≤ R < 2k</td> <td>2mA</td> </tr> <tr> <td>2k ≤ R < 50k</td> <td>1mA</td> </tr> <tr> <td>50k ≤ R < 200k</td> <td>200µA</td> </tr> <tr> <td>200k ≤ R < 1M</td> <td>100µA</td> </tr> <tr> <td>1M ≤ R < 2M</td> <td>50µA</td> </tr> <tr> <td>2M ≤ R</td> <td>30µA</td> </tr> </tbody> </table> <p style="text-align: center;">Table 2: Test current for CRV</p> <div style="text-align: right; margin-top: 10px;">  <p style="text-align: center;">Figure 1: CRV measuring circuit</p> </div>	Standard Total Resistance R (ohm)	Test Current	R ≤ 100	20mA	100 < R < 500	10mA	500 ≤ R < 1k	4mA	1k ≤ R < 2k	2mA	2k ≤ R < 50k	1mA	50k ≤ R < 200k	200µA	200k ≤ R < 1M	100µA	1M ≤ R < 2M	50µA	2M ≤ R	30µA
Standard Total Resistance R (ohm)	Test Current																					
R ≤ 100	20mA																					
100 < R < 500	10mA																					
500 ≤ R < 1k	4mA																					
1k ≤ R < 2k	2mA																					
2k ≤ R < 50k	1mA																					
50k ≤ R < 200k	200µA																					
200k ≤ R < 1M	100µA																					
1M ≤ R < 2M	50µA																					
2M ≤ R	30µA																					
4	Temperature Coefficient of Resistance	<p>The trimmer potentiometer should be subjected to each of the following temperatures (see Table 3) for 30-45 minutes. Temperature coefficient of resistance should be applied to the following formula.</p> $TCR = \frac{R_2 - R_1}{R_1 (T_2 - T_1)} \times 10^6 \text{ (ppm/°C)}$ <p style="margin-left: 20px;"> T_1 : Reference temperature in degrees celsius T_2 : Test temperature in degrees celsius R_1 : Resistance at reference temperature ohm R_2 : Resistance at test temperature in ohm </p> <table border="1" style="margin-left: auto; margin-right: auto; border-collapse: collapse; text-align: center;"> <thead> <tr style="background-color: #f2f2f2;"> <th>Sequence</th> <th>1*</th> <th>2</th> <th>3</th> <th>4*</th> <th>5</th> <th>6</th> </tr> </thead> <tbody> <tr> <td>Temperature (°C)</td> <td>+25</td> <td>-15</td> <td>Min. operating Temperature</td> <td>+25</td> <td>+65</td> <td>Max. operating Temperature</td> </tr> </tbody> </table> <p style="margin-left: 20px;">Note*: Reference temperature</p> <p style="text-align: center;">Table 3: Test temperatures</p>	Sequence	1*	2	3	4*	5	6	Temperature (°C)	+25	-15	Min. operating Temperature	+25	+65	Max. operating Temperature						
Sequence	1*	2	3	4*	5	6																
Temperature (°C)	+25	-15	Min. operating Temperature	+25	+65	Max. operating Temperature																
5	Voltage Setting Stability	<p>The wiper should be set at approximately 40% of the actual effective-electrical rotational angle (number of turns). An adequate DC test potential should be applied between terminal #1 and terminal #3. The voltage between terminal #1 and terminal #3, and the voltage between terminal #1 and terminal #2, should be measured and applied to the following formula.</p> $\text{Voltage setting stability} = \left(\frac{e'}{E} - \frac{e}{E} \right) \times 100 \text{ (\%)}$ <p style="margin-left: 20px;"> e : Before test (The voltage between terminal #1 and terminal #2) e' : After test (The voltage between terminal #1 and terminal #2) E : The voltage between terminal #1 and terminal #3 </p> <div style="text-align: right; margin-top: 10px;">  <p style="text-align: center;">Figure 2</p> </div>																				

Continued on the following page.

SMD Sealed Type/Lead Sealed Type Specifications and Test Methods

Continued from the preceding page.

No.	Item	Test Methods																				
6	Temperature Cycle	<p>The trimmer potentiometer should be subjected to Table 4 temperature for 5 cycles. The trimmer potentiometer should be removed from the chamber, and maintained at a temperature of 25±5°C for 1–2 hours.</p> <table border="1"> <thead> <tr> <th>Sequence</th> <th>1</th> <th>2</th> <th>3</th> <th>4</th> </tr> </thead> <tbody> <tr> <td>Temp. (°C)</td> <td>PV□□ series -55±3</td> <td>+25±2</td> <td>+125±3 +150±3</td> <td>+25±2</td> </tr> <tr> <td></td> <td>PV22 series -25±3</td> <td></td> <td>+60±3</td> <td></td> </tr> <tr> <td>Time (min.)</td> <td>30</td> <td>5 max.</td> <td>30</td> <td>5 max.</td> </tr> </tbody> </table> <p>Table 4: One cycle of temperature cycle.</p>	Sequence	1	2	3	4	Temp. (°C)	PV□□ series -55±3	+25±2	+125±3 +150±3	+25±2		PV22 series -25±3		+60±3		Time (min.)	30	5 max.	30	5 max.
Sequence	1	2	3	4																		
Temp. (°C)	PV□□ series -55±3	+25±2	+125±3 +150±3	+25±2																		
	PV22 series -25±3		+60±3																			
Time (min.)	30	5 max.	30	5 max.																		
7	Humidity	<p>1) PVC6, PV12, PV32, PV34 PVM4A□□□D01 series The trimmer potentiometer should be placed in a chamber at a temperature of 40±2°C and a humidity of 90–95% without loading for 250±8 hours (500±12 hours for PVM4A□□□D01 series). The trimmer potentiometer should be removed from the chamber, and maintained at a temperature of 25±5°C for 5±1/6 hours.</p> <p>2) PVF2 series The trimmer potentiometer should be placed in a chamber at 60±2°C and 90–95% without loading for 1000±12 hours. The trimmer potentiometer should be removed from the chamber, and maintained at a temperature of 25±5°C for 5±1/6 hours</p> <p>2) PVG3, PVG5, PV01, PV22, PV23, PV36, PV37 series The trimmer potentiometer should be subjected Figure-3 the programmed humidity environment for 10 cycle. The trimmer potentiometer should be removed from the chamber, and maintained at a temperature of 25±5°C for 1.5±1/2 hours.</p> <p>Figure 3</p>																				
8	Vibration	<p>1) PV□□ series The trimmer potentiometer should be vibrated throughout the frequency range at the 20G level. A complete frequency range, 10Hz to 2000Hz and back, should be made within 15 minutes for a total of 4 sweeps in each of the three axis direction for a total of 12 sweeps.</p> <p>2) PVF2 series The trimmer potentiometer should be subjected to vibration at 0.3 inch amplitude. The frequency should be varied uniformly between the approximate limits of 10Hz and 55Hz. This motion should be applied for period of 2 hours in each of 3 mutually perpendicular directions (total of 6 hours).</p>																				
9	Shock	<p>1) PV□□ series The trimmer potentiometer should be shocked at the 100G (50G for PV22 and PV23 series) level and should be subjected to 4 shocks in each of the three axis directions for a total of 12 shocks.</p> <p>2) PVM4A□□□D01 series The trimmer potentiometer should be shocked at the 100G level and should be subjected to 3 shocks in each of the six axis directions for a total of 18 shocks.</p>																				
10	Temperature Road Life	<p>Full rated continuous working voltage not exceeding the maximum rated voltage should be applied intermittently between terminal #1 and terminal #3 of the trimmer potentiometer, 1.5 hours on and 0.5 hours off, for a total of 1000±12 hours, at a temperature of 70±2°C (85±2°C for PV01 and PV37 series, 50±2°C for PVF2 series). The trimmer potentiometer should be removed from the chamber, and maintained at a temperature of 25±5°C for 1 to 2 hours.</p>																				
11	High Temperature Exposure (Except for PVF2)	<p>The trimmer potentiometer should be placed in a chamber at a temperature of 125±3°C (150±3°C for PV22 series) 250±8 hours without loading. The trimmer potentiometer should be removed from the chamber, and maintained at a temperature of 25±5°C for 1 to 2 hours.</p>																				
12	Low Temperature Exposure (Except for PVF2 and PVM4A□□□D01)	<p>The trimmer potentiometer should be placed in a chamber at a temperature of -55±3°C for 1 hours without loading. Full rated continuous working voltage not exceeding the maximum rated voltage should be applied for 45 minutes. The trimmer potentiometer should be removed from the chamber, and maintained at a temperature of 25±5°C for approximately 24 hours.</p>																				

Continued on the following page. ↗

SMD Sealed Type/Lead Sealed Type Specifications and Test Methods

☐ Continued from the preceding page.

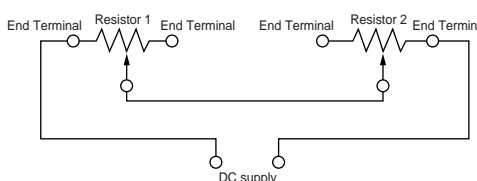
No.	Item	Test Methods
13	Low Temperature Operation (Only for PVF2 and PVM4□□□D01)	The trimmer potentiometer should be placed in a chamber at a temperature of $-25\pm 3^{\circ}\text{C}$ ($-55\pm 3^{\circ}\text{C}$ for PVM4□□□D01 series) 48 ± 4 hours without loading. The trimmer potentiometer should be removed from the chamber, and maintained at a temperature of $25\pm 5^{\circ}\text{C}$ for 1-2 hours
14	Rotational Life	<p>1) PV□□ series Full rated continuous working voltage not exceeding the maximum rated voltage should be applied with the circuit shown in the figure. The adjustment rotor (screw) should be continuously cycled through not less than 90% of effective-electrical rotational angle (number of turns), at the rate of 1 cycle for 5 seconds minimum to 2.5 minutes maximum for total of 200 cycles.</p> <div style="text-align: center;">  <p>Figure 4</p> </div> <p>2) PVG3, PVG5 series The adjustment rotor (screw) should be continuously cycled though not less than 90% of effective-electrical rotational angle (number of turns), at the rate of 1 cycle for 5 seconds minimum to 2.5 minutes maximum for a total of 50 (100 for PVG5) cycles, without loading.</p> <p>3) PVF2, PVM4□□□D01 series The wiper should be rotated over 90% of the effective rotational angle without loading at a speed of 10 cycles per minute, for 100 cycles continuously.</p>

Angle Sensing Potentiometer Specifications and Test Methods

No.	Item	Test Methods															
1	Linearity	<p>Independent linearity should vary no more than ±2% within ±160° to 50% voltage ratio. Taper : linear, 100%/333.3° Measured with the circuit as below (Figure 1).</p> <p>Output voltage ratio (%)</p> $\left(\frac{V(1-2)}{V(1-3)} \times 100 \right)$ <p>Rotational angle (°)</p> <p>Figure-1</p>															
2	Temperature Coefficient of Resistance	<p>The rotary position sensor should be subjected to each of the following temperatures (see Table 1) for 30-45 minutes. Temperature coefficient of resistance should be applied to the following formula.</p> $TCR = \frac{R_2 - R_1}{R_1 (t_2 - t_1)} \times 10^6 \text{ (ppm/°C)}$ <p>t₁ : Reference temperature in degrees celsius t₂ : Test temperature in degrees celsius R₁ : Resistance at reference temperature in ohm R₂ : Resistance at test temperature in ohm</p> <table border="1"> <thead> <tr> <th>Sequence</th> <th>*1</th> <th>2</th> <th>*3</th> <th>4</th> </tr> </thead> <tbody> <tr> <td>Temperature (°C)</td> <td>+25</td> <td>-40</td> <td>+25</td> <td>+85</td> </tr> </tbody> </table> <p>Note * : Reference temperature</p> <p>Table-1 Test temperatures</p>	Sequence	*1	2	*3	4	Temperature (°C)	+25	-40	+25	+85					
Sequence	*1	2	*3	4													
Temperature (°C)	+25	-40	+25	+85													
3	Temperature Cycle (Thermal Shock)	<p>The rotary position sensor should be subjected to Table 2 temperature for 5 cycles. Then, the rotary position sensor should be kept in the dry box for 24 +8/-0 hrs.</p> <table border="1"> <thead> <tr> <th>Sequence</th> <th>1</th> <th>2</th> <th>3</th> <th>4</th> </tr> </thead> <tbody> <tr> <td>Temperature (°C)</td> <td>-40±3</td> <td>+25±2</td> <td>+85±3</td> <td>+25±2</td> </tr> <tr> <td>Time (min.)</td> <td>30</td> <td>5 max.</td> <td>30</td> <td>5 max.</td> </tr> </tbody> </table> <p>Table 2: One cycle of temperature cycle</p>	Sequence	1	2	3	4	Temperature (°C)	-40±3	+25±2	+85±3	+25±2	Time (min.)	30	5 max.	30	5 max.
Sequence	1	2	3	4													
Temperature (°C)	-40±3	+25±2	+85±3	+25±2													
Time (min.)	30	5 max.	30	5 max.													
4	Humidity	<p>The rotary position sensor should be stored in a chamber at temperature of +60±2°C and relative Humidity of 90-95% for 250±8 hrs. After removing from the chamber, the rotary position sensor should be kept in the dry box for 24 +8/-0 hours.</p>															
5	Vibration	<p>The rotary position sensor should be tested under the condition of the amplitude of 1.5mm, the frequency range from 10 to 55Hz (should be traversed in approximately one minute) and 2 hours in each of 3 mutually perpendicular directions (total 6 hours). Then, the rotary position sensor should be kept in the dry box for 1-2 hrs.</p>															
6	Shock	<p>The rotary position sensor should be tested under the condition of the peak acceleration 20G max. in half-sine wave and 5 shocks in each of 3 mutually perpendicular directions (total 15 shocks). Then, the rotary position sensor should be kept in the dry box for 1-2 hrs.</p>															
7	Humidity Load Life	<p>Full rated continuous working voltage not exceeding 5Vdc should be applied intermittently between terminal #1 and terminal #3 of the rotary position sensor, 1.5 hours on and 0.5 hours off, for 96±4 hours in total in a chamber at a temperature of +40±2°C and relative humidity of 90-95%. After removing from the chamber, the rotary position sensor should be kept in the dry box for 24 +8/-0 hours.</p>															
8	High Temp. Exposure	<p>The rotary position sensor should be stored in a chamber at the temperature of +85±3°C without loading for 250±8 hours. After removing from the chamber, the rotary position sensor should be kept in the dry box for 24 +8/-0 hours.</p>															
9	Low Temp. Exposure	<p>The rotary position sensor should be stored in a chamber at the temperature of -40±3°C without loading for 168±4 hours. After removing from the chamber, the rotary position sensor should be kept in the dry box for 24 +8/-0 hours.</p>															
10	Rotational Life	<p>The adjustment rotor should be continuously rotated within ±160° of effective electrical rotational angle, at the rate of one cycle for 6 seconds for 1 Million cycles under the condition of +25±2°C of temperature without loading.</p>															

Packaging

■ Minimum Quantity

Part Number	Minimum Quantity (pcs.)					
	ø180mm reel	ø330mm reel	Ammo Pack	Magazine	Bulk	Tray
PVZ2A	3000	12000	—	—	1000	—
PVZ2K	3000	—	—	—	1000	—
PVZ3A	2000	8000	—	—	1000	—
PVZ3K/R	1500	—	—	—	1000	—
PVS3	2500	8000	—	—	500	—
PVA3	2000	8000	—	—	500	—
PVG3A/G	1000	—	—	—	500	—
PVG3K	500	—	—	—	—	—
PVM4	500	3000	—	—	500	—
PVF2A	500	—	—	—	100	—
PVG5A	250	—	—	—	50	—
PVG5H	500	—	—	—	50	—
PV01W	—	—	—	50	—	—
PV01P	—	—	—	50	—	—
PV01X	—	—	—	50	—	—
PVC6A/D/G/H/E	—	—	—	50	50	—
PVC6M/Q	—	—	1000	50	50	—
PV34	—	—	—	—	100	—
PV32	—	—	—	—	100	—
PV23/12	—	—	—	—	50	—
PV22	—	—	—	—	30	—
PV36W	—	—	1000	50	50	—
PV36Y	—	—	—	50	50	—
PV36X	—	—	1000	40	50	—
PV36Z/P	—	—	—	40	50	—
PV37Y/Z	—	—	1000	—	50	—
PV37W/X/P	—	—	—	—	50	—
PVS1A	—	1000	—	—	50	—
PVS1L	—	—	—	—	—	1000

■ Dimensions of Reel

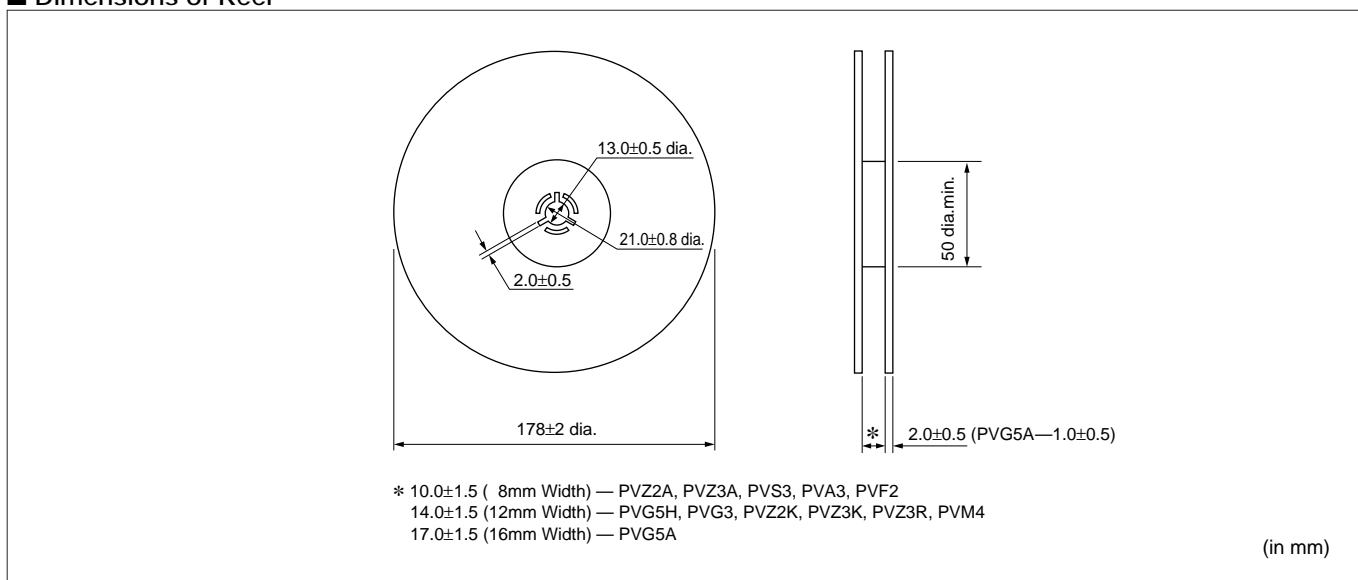

Continued on the following page. ↗

Packaging

☐ Continued from the preceding page.

■ Dimensions of Plastic Tape

PVG3K

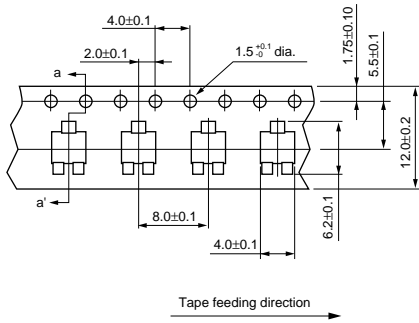

(in mm)

PVS1

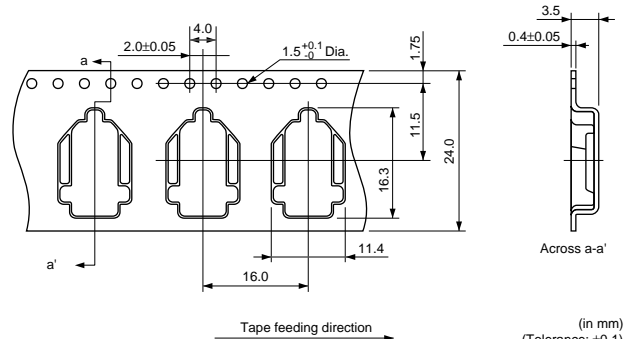

(in mm)
(Tolerance: ± 0.1)

■ Dimensions of Radial Taping

PVC6M

0.55W×3.2L×1.3D

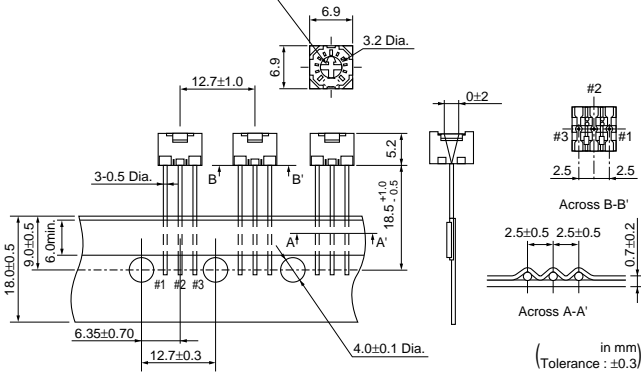

(in mm)
(Tolerance: ± 0.3)

PVC6Q

0.55W×3.2L×1.3D

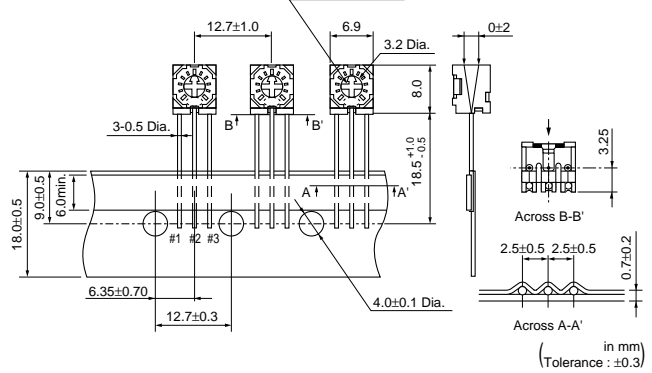

(in mm)
(Tolerance: ± 0.3)

PV37Y

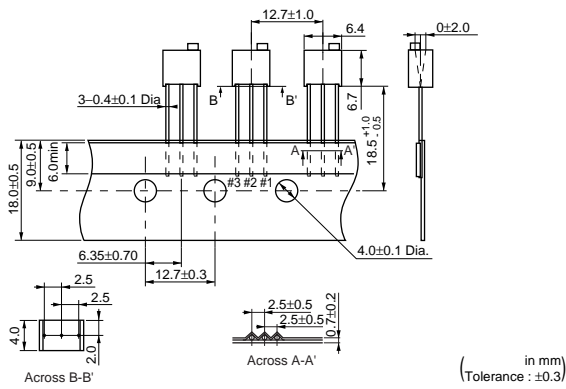

(in mm)
(Tolerance: ± 0.3)

PV37Z

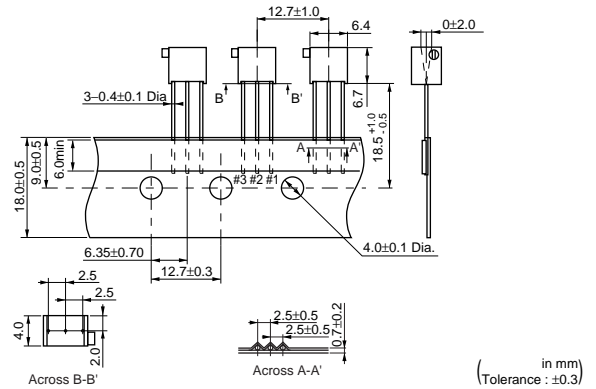

(in mm)
(Tolerance: ± 0.3)

☐ Continued on the following page.

Packaging

☐ Continued from the preceding page.

■ Dimensions of Radial Taping

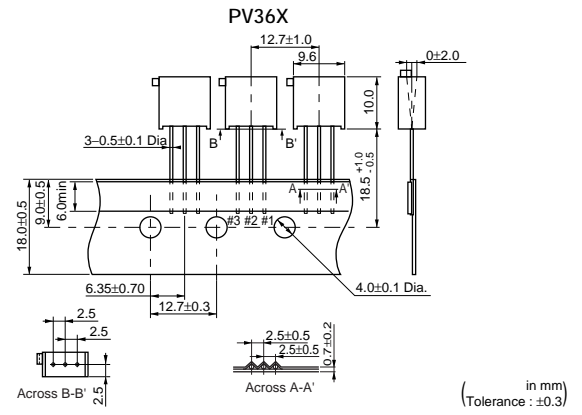
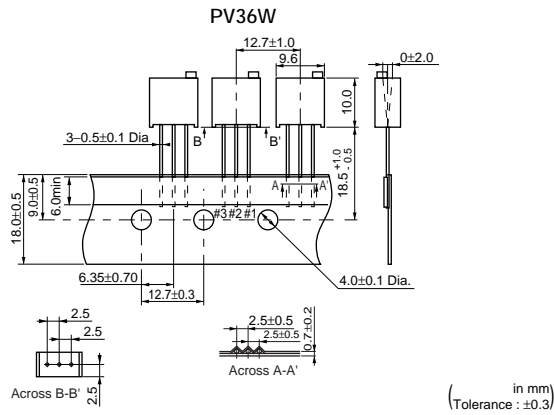

■ Dimensions of Ammo Pack

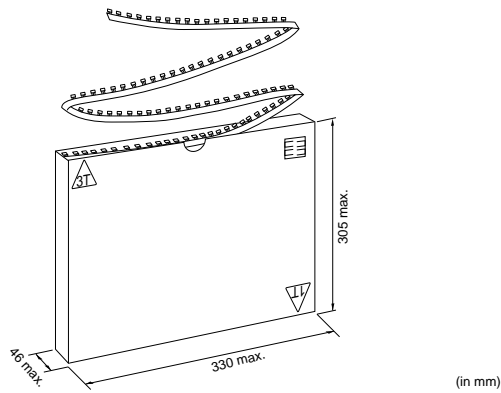

■ Dimensions of Magazine Packaging

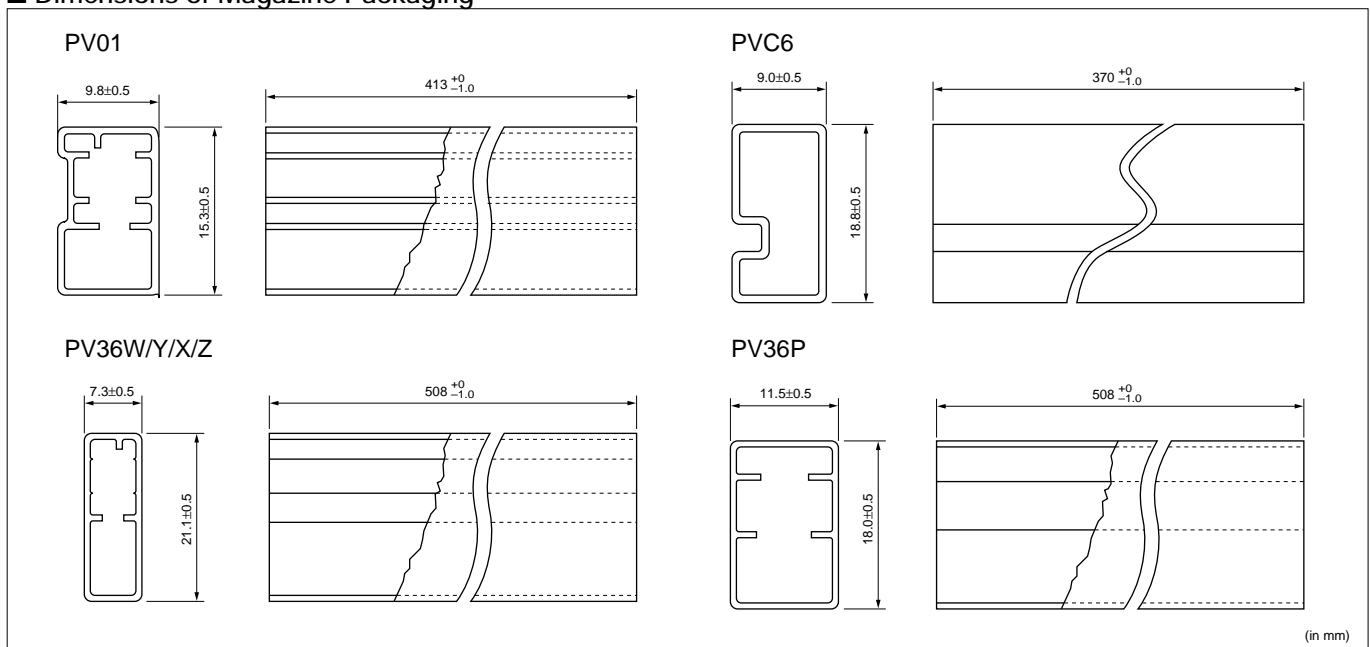

Recommended Adjustment Tools/Qualified Standards

■ Recommended Adjustment Tools

Trimmer Potentiometer Series	Manufacturers	Model Number	MURATA Model Number	Blade
PVZ2	MURATA MFG.	KMDR090	KMDR090	- Minus (round edge)
PVZ2A_A04	VESSEL MFG.	No.9000+0X30	KMDR150	+ Cross
PVZ3	VESSEL MFG.	No.9000+1.7X30	KMDR080	+ Cross
	TORAY INDUSTRIES, INC.	SA-2225	KMDR070	- Minus (round edge)
PVA3	VESSEL MFG.	No.9000+1.7X30	KMDR080	+ Cross
	TORAY INDUSTRIES, INC.	SA-2225	KMDR070	- Minus (round edge)
PVS3	TORAY INDUSTRIES, INC.	SA-2225	KMDR070	- Minus (round edge)
PVG3	TORAY INDUSTRIES, INC.	SA-2225	KMDR070	- Minus (round edge)
PVM4	VESSEL MFG.	No.9000-2.6X30	KMDR120	- Minus
PVG5	VESSEL MFG.	No.9000-1.3X30	KMDR130	- Minus
	ENGINEER INC.	DA-54		- Minus
PVC6	VESSEL MFG.	No.9000+0X30	KMDR150	+ Cross
	TORAY INDUSTRIES, INC.	SA-2225	KMDR070	- Minus (round edge)
others	VESSEL MFG.	No.9000-1.8X30	KMDR110	- Minus
	ENGINEER INC.	DA-40	KMDR180	- Minus (both ends)
		DA-55		- Minus

■ For Automatic Adjustment

Trimmer Potentiometer Series	Manufacturers	Model Number	MURATA Model Number	Blade
PVZ3 PVA3 PVS3 PVG3	TORAY INDUSTRIES, INC.	JB-2225	KMBT070	- Minus (round edge)
PVC6	VESSEL MFG.	No.CA-10	KMBT090	+ Cross
	TORAY INDUSTRIES, INC.	JB-2225	KMBT070	- Minus (round edge)

■ Qualified Standards

The products listed here have been produced by the QS9000 and ISO9001 certified factory.

MURATA FACTORY	Qualified Date	Standard	Qualified Number
Sabae Murata Mfg.Co.,Ltd.	August 14, 1997	UNDERWRITERS LABORATORIES INC.	A5704
Wuxi Murata Electronis Co.,Ltd.	May 12, 1999	UNDERWRITERS LABORATORIES INC.	A7924

* No ODCs (Ozone Depleting Chemicals) are used on all Murata's trimmer potentiometers.

⚠Note:

1. Export Control

⟨For customers outside Japan⟩

Murata products should not be used or sold for use in the development, production, stockpiling or utilization of any conventional weapons or mass-destructive weapons (nuclear weapons, chemical or biological weapons, or missiles), or any other weapons.

⟨For customers in Japan⟩

For products which are controlled items subject to the "Foreign Exchange and Foreign Trade Law" of Japan, the export license specified by the law is required for export.

2. Please contact our sales representatives or product engineers before using the products in this catalog for the applications listed below, which require especially high reliability for the prevention of defects which might directly damage to a third party's life, body or property, or when one of our products is intended for use in applications other than those specified in this catalog.

- | | |
|-----------------------------|---|
| ① Aircraft equipment | ② Aerospace equipment |
| ③ Undersea equipment | ④ Power plant equipment |
| ⑤ Medical equipment | ⑥ Transportation equipment (vehicles, trains, ships, etc.) |
| ⑦ Traffic signal equipment | ⑧ Disaster prevention / crime prevention equipment |
| ⑨ Data-processing equipment | ⑩ Application of similar complexity and/or reliability requirements to the applications listed in the above |

3. Product specifications in this catalog are as of April 2004. They are subject to change or our products in it may be discontinued without advance notice. Please check with our sales representatives or product engineers before ordering. If there are any questions, please contact our sales representatives or product engineers.

4. Please read rating and ⚠CAUTION (for storage, operating, rating, soldering, mounting and handling) in this catalog to prevent smoking and/or burning, etc.

5. This catalog has only typical specifications because there is no space for detailed specifications. Therefore, please approve our product specifications or transact the approval sheet for product specifications before ordering.

6. Please note that unless otherwise specified, we shall assume no responsibility whatsoever for any conflict or dispute that may occur in connection with the effect of our and/or a third party's intellectual property rights and other related rights in consideration of your use of our products and/or information described or contained in our catalogs. In this connection, no representation shall be made to the effect that any third parties are authorized to use the rights mentioned above under licenses without our consent.

7. No ozone depleting substances (ODS) under the Montreal Protocol are used in our manufacturing process.