

阅读申明

- 1.本站收集的数据手册和产品资料都来自互联网，版权归原作者所有。如读者和版权方有任何异议请及时告之，我们将妥善解决。
- 2.本站提供的中文数据手册是英文数据手册的中文翻译，其目的是协助用户阅读，该译文无法自动跟随原稿更新，同时也可能存在翻译上的不当。建议读者以英文原稿为参考以便获得更精准的信息。
- 3.本站提供的产品资料，来自厂商的技术支持或者使用者的心得体会等，其内容可能存在描述上的差异，建议读者做出适当判断。
- 4.如需与我们联系，请发邮件到marketing@iczoom.com，主题请标有“数据手册”字样。

Read Statement

1. The datasheets and other product information on the site are all from network reference or other public materials, and the copyright belongs to the original author and original published source. If readers and copyright owners have any objections, please contact us and we will deal with it in a timely manner.
2. The Chinese datasheets provided on the website is a Chinese translation of the English datasheets. Its purpose is for reader's learning exchange only and do not involve commercial purposes. The translation cannot be automatically updated with the original manuscript, and there may also be improper translations. Readers are advised to use the English manuscript as a reference for more accurate information.
3. All product information provided on the website refer to solutions from manufacturers' technical support or users the contents may have differences in description, and readers are advised to take the original article as the standard.
4. If you have any questions, please contact us at marketing@iczoom.com and mark the subject with "Datasheets" .

NOTES:

1. MATERIALS AND FINISHES:

- BODY & SHELL - STAINLESS STEEL, PASSIVATED
- CONTACT - BeCu, GOLD PLATING
- INSULATOR - PTFE, NATURAL
- GASKET - SILICONE RUBBER, RED
- RETAINER RING - SUS303, NATURAL

2. ELECTRICAL:

- A. IMPEDANCE: 50 OHM
- B. FREQUENCY RANGE: DC - 6 GHz
- C. AVERAGE INPUT POWER: 2W MAX AT +25°C
DERATED LINEARLY TO 0.5W MAX AT +125°C
- D. ATTENUATION: XX dB ± (SEE TABLE 2D)
- E. VSWR: (SEE TABLE 2E)

3. MECHANICAL:

- A. MATING ENGAGEMENT: MIL-STD-348A, SERIES SMA
- B. ENGAGE/DISENGAGE FORCE: 2 IN-LBS MAX
- C. MATING TORQUE: 8 IN-LBS MAX
- D. COUPLING PROOF TORQUE: 15 IN-LBS MIN
- E. COUPLING NUT RETENTION: 60 LBS MIN
- F. DURABILITY: 500 CYCLES MIN.

4. ENVIRONMENTAL:

- A. OPERATING TEMPERATURE: -55°C TO +125°C
- B. THERMAL SHOCK: MIL-STD-202, METHOD 107, CONDITION B (EXCEPT HIGH TEMP +100°C)
- C. SHOCK: MIL-STD-202, METHOD 213, CONDITION 1
- D. VIBRATION: MIL-STD-202, METHOD 204, CONDITION 1D

5. PACKAGING:

- A. QUANTITY: SINGLE PACK
- B. BAG TO BE MARKED: AMPHENOL RF
ATS-IMIF-XXDB2W
DATE CODE

THIRD ANGLE PROJ.

REVISIONS

REV	DESCRIPTION	DATE	ECO	APPR
A	RELEASE TO MFG.	12/15/14	50303	CL/BCG

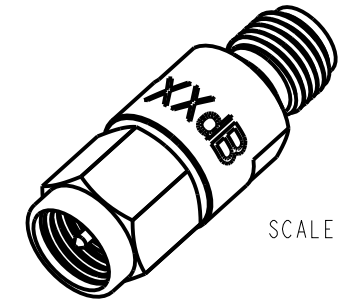

SCALE 2.000

dB	DC-4 GHz	4-6 GHz
1-3	±0.3	±0.5
4-6	±0.4	±0.5
7-10	±0.5	±0.5

TABLE 2D: ATTENUATION ACCURACY

dB	DC-2.5 GHz	2.5-4 GHz	4-6 GHz
1-3	1.15:1	1.20:1	1.25:1
4-6	1.15:1	1.20:1	1.25:1
7-10	1.15:1	1.25:1	1.30:1

TABLE 2E: VSWR MAX.

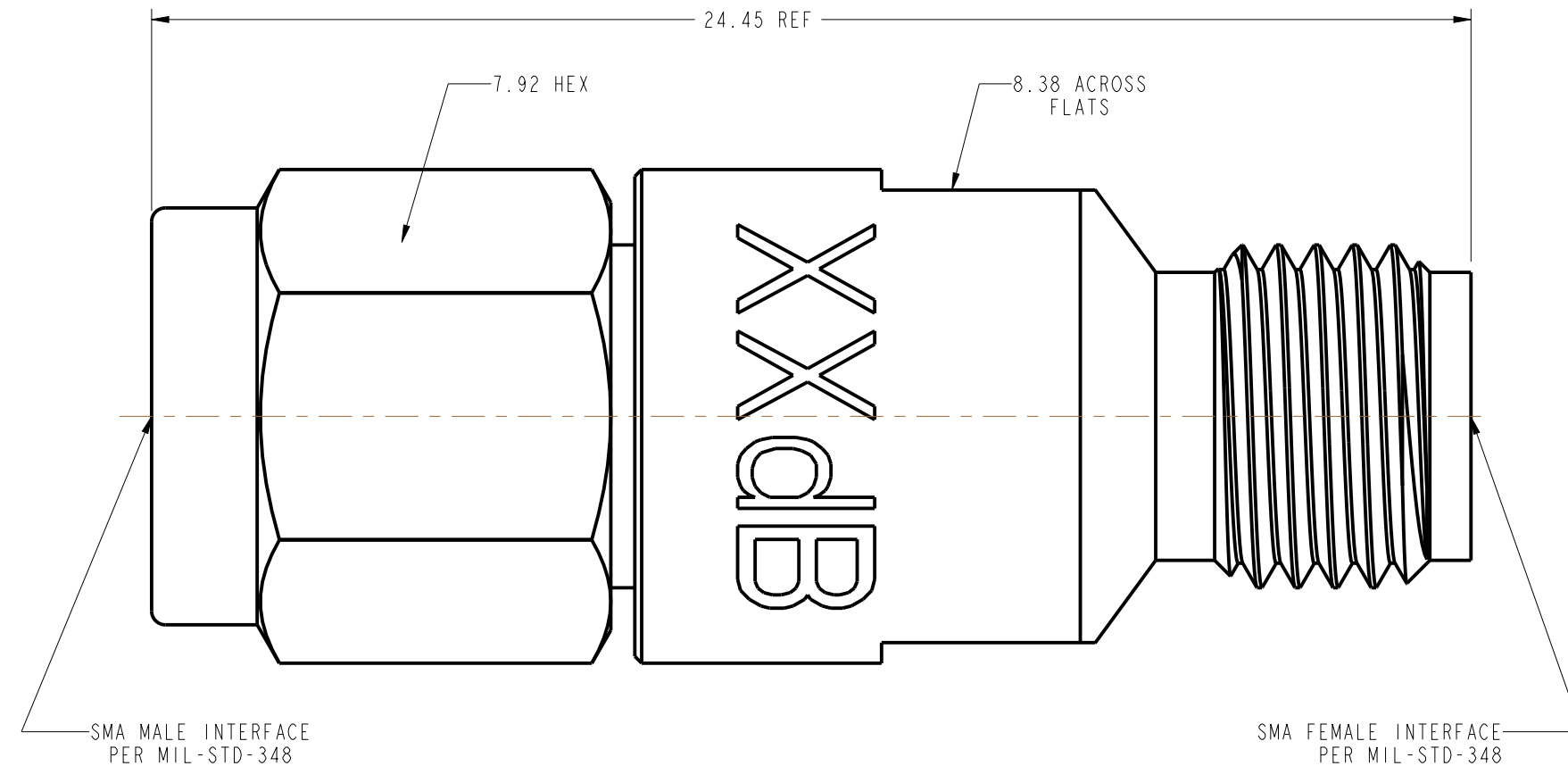

CUSTOMER OUTLINE DRAWING

ALL OTHER SHEETS ARE FOR INTERNAL USE ONLY

<p>UNLESS OTHERWISE SPECIFIED, DIMENSIONS ARE IN METRIC AND TOLERANCES ARE: <0.5mm ±0.05mm 0.5 - 6mm ±0.1mm 6 - 30mm ±0.2mm 30 - 120mm ±0.3mm ANGLES ±1°</p> <p>NOTICE - These drawings, specifications, or other data (1) are, and remain the property of Amphenol corp. (2) must be returned upon request; and (3) are confidential and not to be disclosed to any person other than those to whom they are given by Amphenol Corp. the furnishing of these drawings, specifications, or other data by Amphenol Corp., or to any other person to anyone for any purpose is not to be regarded by implication or otherwise in any manner licensing, granting rights to permitting such holder or any other person to manufacture, use or sell any product, process or design, patented or otherwise, that may in any way be related to or disclosed by said drawings, specifications, or other data.</p>	MATERIAL SEE NOTES	DRAWN CLEMENT	DATE 10-Nov-14	TITLE SMA STR PLUG TO JACK FIXED ATTENUATOR	Amphenol RF www.amphenolrf.com	
	REFERENCE EAR # 6465	ENGINEER B.GLEISSNER	DATE 10-Nov-14			
	CONFIGURATION LEVEL: In Work	APPROVED K. CAPOZZI	DATE 12/11/14	SCALE: 8.0:1.0	SHEET 2 OF 2	DRAWING NO.ATS-IMIF-XXDB2W
	FINISH	CAD FILE	DWG SIZE B	REV A	ITEM NO.ATS-IMIF-XXDB2W	PART NO.ATS-IMIF-XXDB2W