

阅读申明

- 1.本站收集的数据手册和产品资料都来自互联网，版权归原作者所有。如读者和版权方有任何异议请及时告之，我们将妥善解决。
- 2.本站提供的中文数据手册是英文数据手册的中文翻译，其目的是协助用户阅读，该译文无法自动跟随原稿更新，同时也可能存在翻译上的不当。建议读者以英文原稿为参考以便获得更精准的信息。
- 3.本站提供的产品资料，来自厂商的技术支持或者使用者的心得体会等，其内容可能存在描述上的差异，建议读者做出适当判断。
- 4.如需与我们联系，请发邮件到marketing@iczoom.com，主题请标有“数据手册”字样。

Read Statement

1. The datasheets and other product information on the site are all from network reference or other public materials, and the copyright belongs to the original author and original published source. If readers and copyright owners have any objections, please contact us and we will deal with it in a timely manner.
2. The Chinese datasheets provided on the website is a Chinese translation of the English datasheets. Its purpose is for reader's learning exchange only and do not involve commercial purposes. The translation cannot be automatically updated with the original manuscript, and there may also be improper translations. Readers are advised to use the English manuscript as a reference for more accurate information.
3. All product information provided on the website refer to solutions from manufacturers' technical support or users the contents may have differences in description, and readers are advised to take the original article as the standard.
4. If you have any questions, please contact us at marketing@iczoom.com and mark the subject with "Datasheets" .

RoHS Compliant & Pb-Free Product
Package Style: Standard Batwing



Features

- 5 MHz to 2500MHz Operation
- Internally Matched Input and Output
- 16dB Small Signal Gain
- 1.6dB Noise Figure
- +22dBm Output Power
- Single 6V to 9V Positive Power Supply

Applications

- CATV Distribution Amplifiers
- Cable Modems
- Broadband Gain Blocks
- Laser Diode Driver
- Return Channel Amplifier
- Base Stations

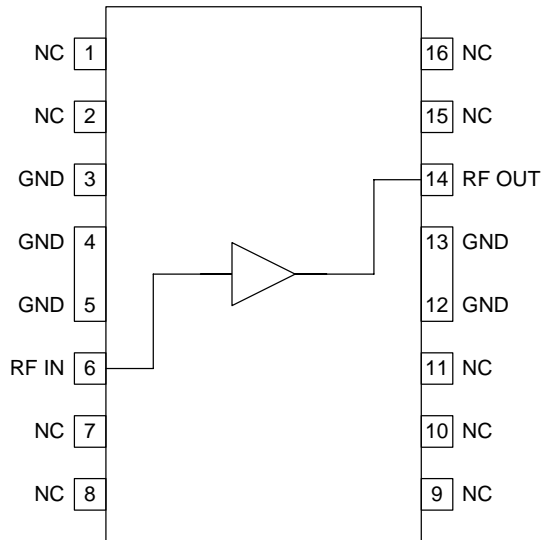

Functional Block Diagram

Product Description

The RF2320 is a general purpose, low-cost, high-linearity RF amplifier IC. The device is manufactured on a Gallium Arsenide process and is featured in an SOP-16 batwing package. It has been designed for use as an easily cascadable 75Ω gain block with a noise figure of less than 2dB. Gain flatness better than 0.5dB from 5MHz to 1000MHz, and high linearity make this part ideal for cable TV applications. Other applications include IF and RF amplification in wireless voice and data communication products operating in frequency bands up to 2500MHz. The device is self-contained with 75Ω input and output impedances providing 2:1 VSWR matching. For higher input and output return losses, see the evaluation schematic.

Ordering Information

RF2320 Linear General Purpose Amplifier
RF2320PCBA-41X Fully Assembled Evaluation Board

Optimum Technology Matching® Applied

- | | | | |
|---|--------------------------------------|-------------------------------------|-----------------------------------|
| <input type="checkbox"/> GaAs HBT | <input type="checkbox"/> SiGe BiCMOS | <input type="checkbox"/> GaAs pHEMT | <input type="checkbox"/> GaN HEMT |
| <input checked="" type="checkbox"/> GaAs MESFET | <input type="checkbox"/> Si BiCMOS | <input type="checkbox"/> Si CMOS | |
| <input type="checkbox"/> InGaP HBT | <input type="checkbox"/> SiGe HBT | <input type="checkbox"/> Si BJT | |

RF MICRO DEVICES®, RFMD®, Optimum Technology Matching®, Enabling Wireless Connectivity™, PowerStar®, POLARIS™ TOTAL RADIO™ and UltimateBlue™ are trademarks of RFMD, LLC. BLUETOOTH is a trademark owned by Bluetooth SIG, Inc., U.S.A. and licensed for use by RFMD. All other trade names, trademarks and registered trademarks are the property of their respective owners. ©2006, RF Micro Devices, Inc.

Absolute Maximum Ratings

Parameter	Rating	Unit
Device Current	175	mA
Device Voltage	9	V
Input RF Power	+10	dBm
Output Load VSWR	20:1	
Ambient Operating Temperature	-40 to +85	°C
Storage Temperature	-40 to +150	°C



Caution! ESD sensitive device.

The information in this publication is believed to be accurate and reliable. However, no responsibility is assumed by RF Micro Devices, Inc. ("RFMD") for its use, nor for any infringement of patents, or other rights of third parties, resulting from its use. No license is granted by implication or otherwise under any patent or patent rights of RFMD. RFMD reserves the right to change component circuitry, recommended application circuitry and specifications at any time without prior notice.

RoHS status based on EU Directive 2002/95/EC (at time of this document revision).

Parameter	Specification			Unit	Condition
	Min.	Typ.	Max.		
Overall					T = 25 °C, P _{IN} = -8dBm, Freq = 1000MHz unless otherwise specified
Frequency Range		5 to 2500		MHz	
Input VSWR		1.7:1	2:1		
Output VSWR		1.3:1	1.7:1		
Reverse Isolation	20	22		dB	
Supply Voltage (V _{DD})	6	7	9	V	
50Ω Board					
V_{DD} = 6V					
Gain	14.5	15.6	17.0	dB	At 100MHz
	15.0	17.0	19.0	dB	At 2000MHz
Noise Figure		1.8	2.0	dB	
Output IP ₃	30	33		dBm	At 100MHz
	29	32		dBm	At 1000MHz
Output IP ₂	40	43		dBm	At 1000MHz
Output P _{1dB}	20	21.5		dBm	At 100MHz
	20	22		dBm	At 1000MHz
Current	68	78	88	mA	
V_{DD} = 7V					
Gain	14	16	18	dB	At 100MHz
	15	17	19	dB	At 1000MHz
Noise Figure		1.8	2.0	dB	
Output IP ₃	32	34		dBm	At 100MHz
	31	33		dBm	At 1000MHz
Output IP ₂	41	43		dBm	At 1000MHz
Output P _{1dB}	20	22		dBm	At 100MHz
	21	23		dBm	At 1000MHz
Current	70	80	90	dB	
Gain Flatness		±0.5	±0.9	dB	40MHz, 1000MHz and 1500MHz relative to 500MHz

Parameter	Specification			Unit	Condition
	Min.	Typ.	Max.		
V_{DD} = 9V					
Gain	14	16	18	dB	At 100MHz
	15	17	19	dB	At 1000MHz
Noise Figure		1.8	2.0	dB	
Output IP ₃	30	35		dBm	At 100MHz
	32	34		dBm	At 1000MHz
Output IP ₂	41	43		dBm	At 1000MHz
Output P _{1dB}	21	23		dBm	At 100MHz
	23	25		dBm	At 1000MHz
Current	75	85	95	mA	
75Ω Board					
V_{DD} = 6V					
Gain	13.8	15.3	16.8	dB	At 100MHz
	14.5	16	17.5	dB	At 2000MHz
Noise Figure		2.0	2.5	dB	
Output IP ₃	32	34		dBm	At 100MHz
	27.5	29.5		dBm	At 1000MHz
Output IP ₂	38	40		dBm	At 1000MHz
Output P _{1dB}	19	20.5		dBm	At 100MHz
	18.5	20		dBm	At 1000MHz
Current	65	75	85	mA	
V_{DD} = 7V					
Gain	14	15.5	17	dB	At 100MHz
	14.5	16	17.5	dB	At 1000MHz
Noise Figure		2.0	2.5	dB	
Output IP ₃	32	36		dBm	At 100MHz
	28	30		dBm	At 1000MHz
Output IP ₂	38	41		dBm	At 1000MHz
Output P _{1dB}	20	21.5		dBm	At 100MHz
	19.5	21		dBm	At 1000MHz
Current	67	77	87	dB	
V_{DD} = 9V					
Gain	14	15.5	17.0	dB	At 100MHz
	14.5	16	17.5	dB	At 1000MHz
Noise Figure		2.0	2.5	dB	
Output IP ₃	34	36		dBm	At 100MHz
	29.5	31.5		dBm	At 1000MHz
Output IP ₂	39	41		dBm	At 1000MHz
Output P _{1dB}	21.5	23		dBm	At 100MHz
	19.5	21		dBm	At 1000MHz
Current	70	80	90	mA	

Parameter	Specification			Unit	Condition
	Min.	Typ.	Max.		
110 Channels					10 dBmV per channel, flat, at the input of the amplifier; $V_{CC} = 7V$, $I_{CC} = 75mA$
XMOD		-71		dBc	At 55.25 MHz
		-72		dBc	At 331.25 MHz
		-72		dBc	At 547.25 MHz
CTB		-79		dBc	At 55.25 MHz
		-78		dBc	At 331.25 MHz
		-78		dBc	At 547.25 MHz
CSO+1.25MHz		-91		dBc	At 55.25 MHz
		-58		dBc	At 331.25 MHz
		-56		dBc	At 547.25 MHz
CSO-1.25MHz		-51		dBc	At 55.25 MHz
		-53		dBc	At 331.25 MHz
		-58		dBc	At 547.25 MHz
CNR		+65		dB	At 55.25 MHz
		+64		dB	At 331.25 MHz
		+64		dB	At 547.25 MHz

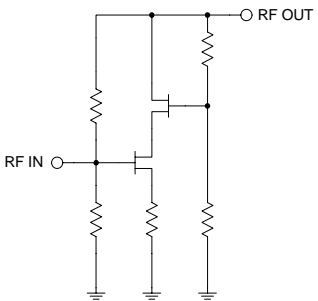
Pin	Function	Description	Interface Schematic
1	NC	No connection. This pin should be connected to the ground plane.	
2	NC	Same as pin 1.	
3	GND	Ground connection. Keep traces physically short and connect immediately to ground plane for best performance. Each ground pin should have a via to the ground plane.	
4	GND	Same as pin 3.	
5	GND	Same as pin 3.	
6	RF IN	RF input pin. This pin is not internally DC blocked. A DC blocking capacitor suitable for the frequency of operation is required if DC is present from the previous stage. The gate voltage is nominally 0V but can be raised externally to increase the bias level. This will increase the current drain but improve linearity.	
7	NC	Same as pin 1.	
8	NC	Same as pin 1.	
9	NC	Same as pin 1.	
10	NC	Same as pin 1.	
11	NC	Same as pin 1.	
12	GND	Same as pin 3.	
13	GND	Same as pin 3.	
14	RF OUT	RF output and bias pin. Because DC is present on this pin, a DC blocking capacitor, suitable for the frequency of operation, should be used in most applications. For biasing, only an RF choke is needed.	
15	NC	Same as pin 1.	
16	NC	Same as pin 1.	

Package Drawing

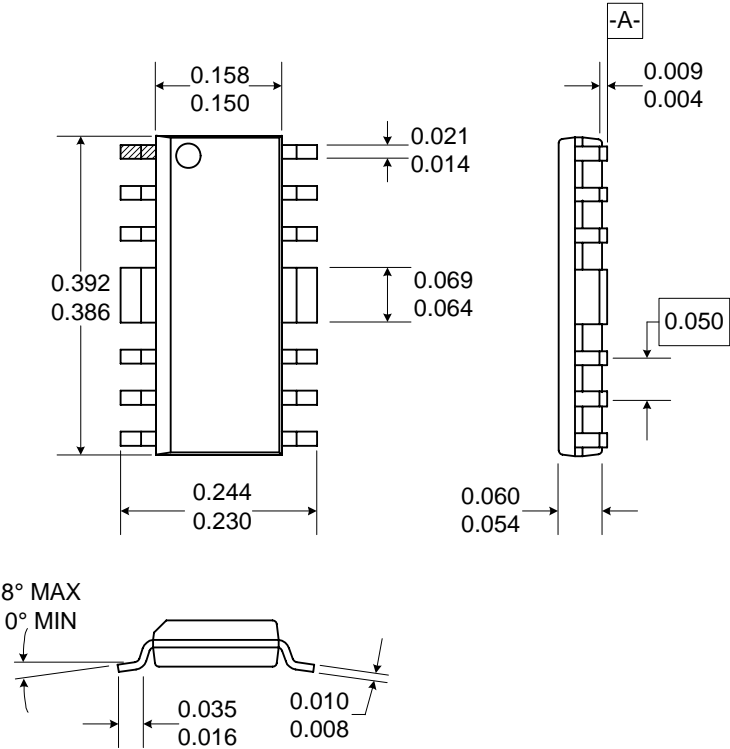

**Application Schematic
1930-1990 MHz Narrowband Operation**

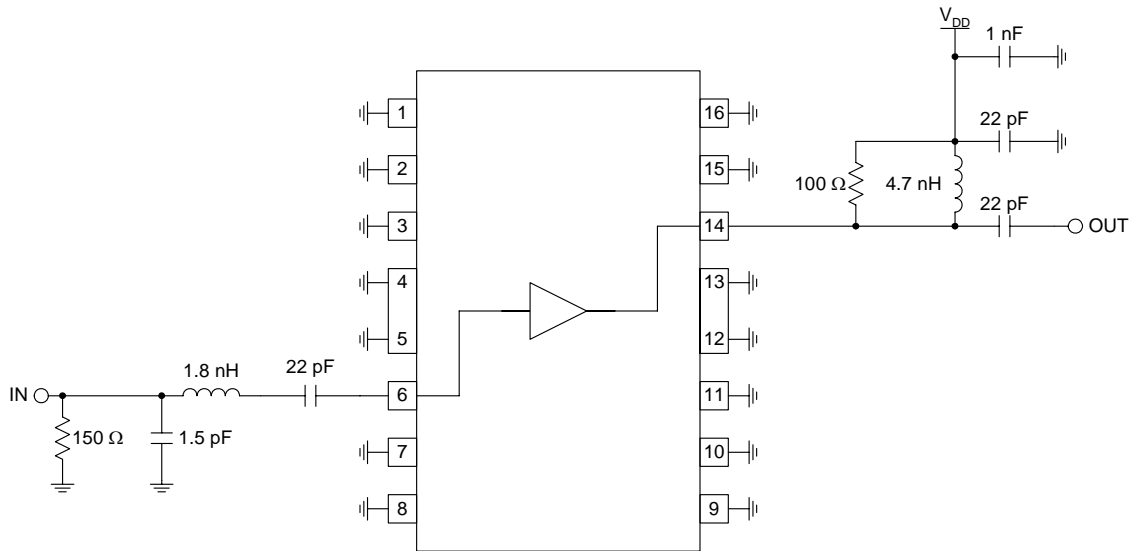

**Application Schematic
869-894 MHz Narrowband Operation**

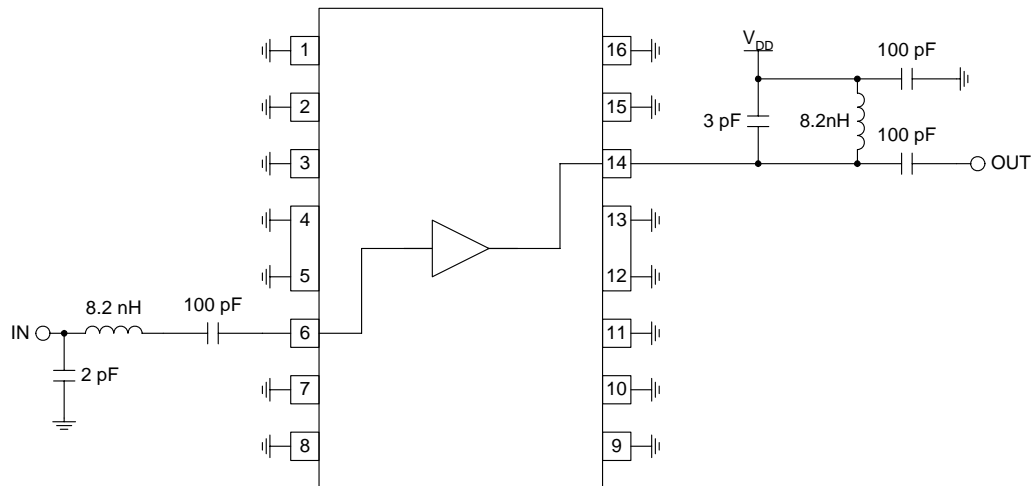

Application Schematic Push-Pull Standard Voltage

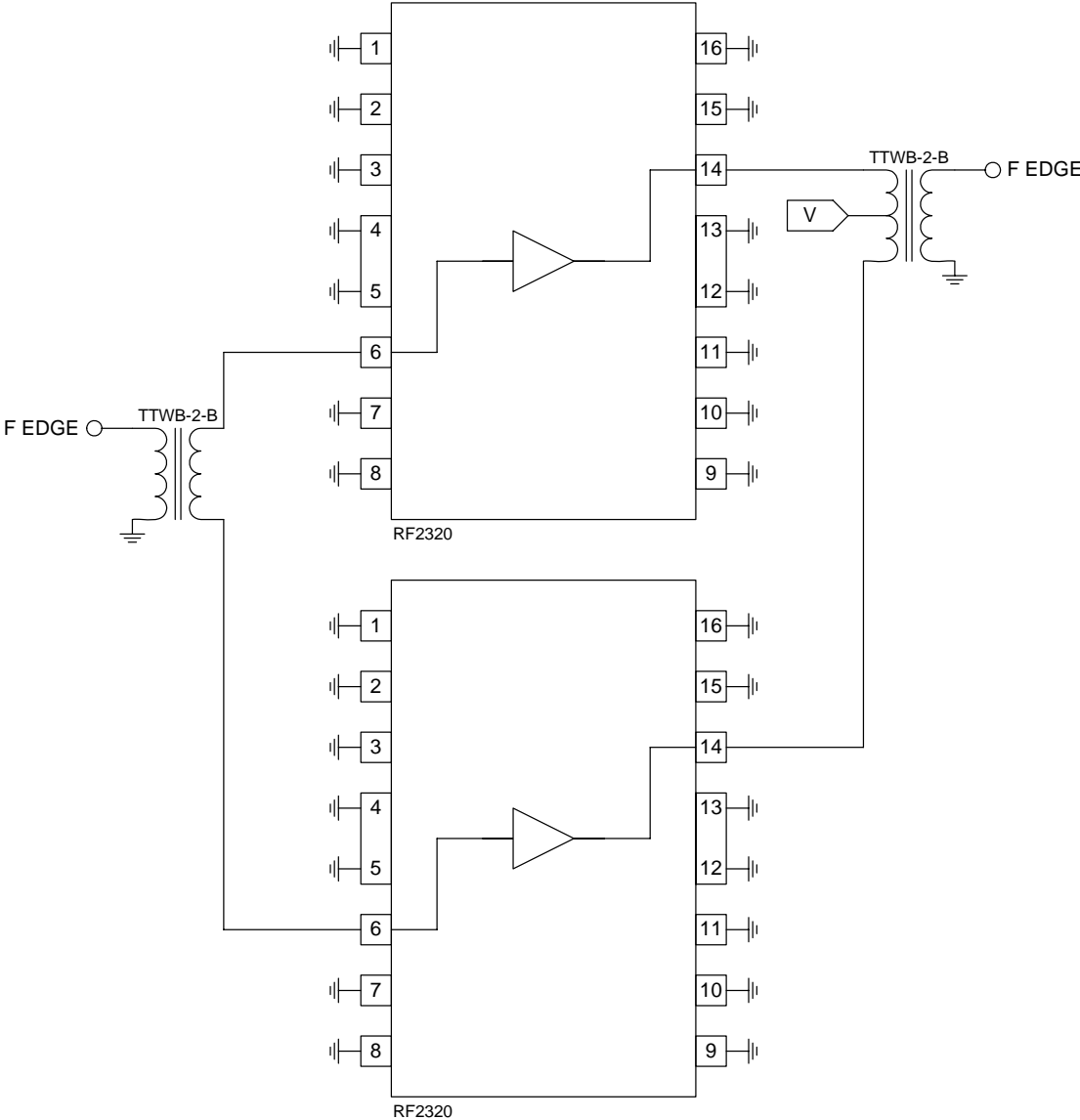

**Application Schematic
Push-Pull 24V**

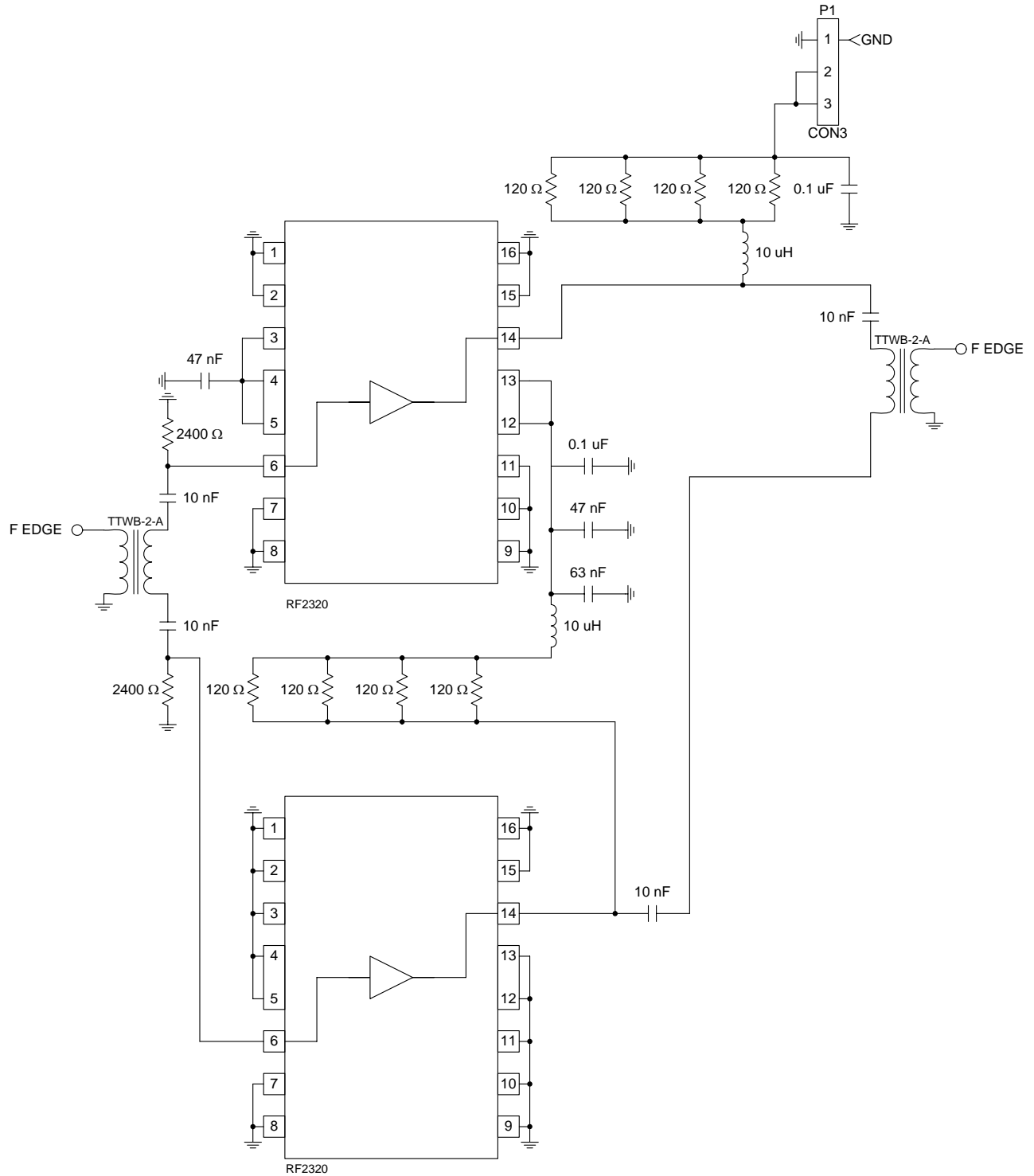

Evaluation Board Schematic - 50Ω

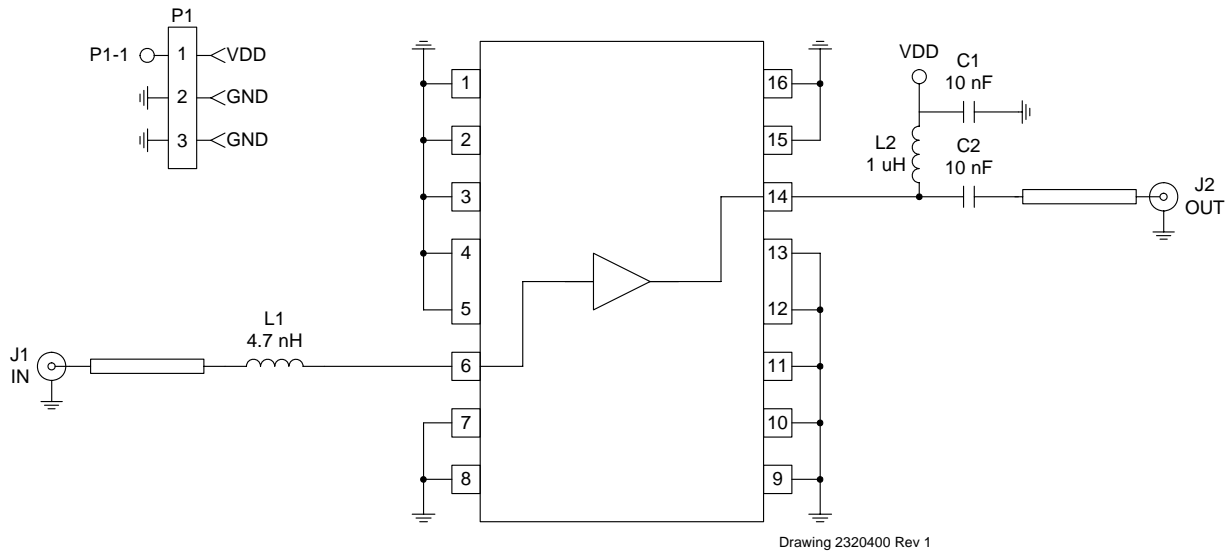

Evaluation Board Schematic - 75Ω

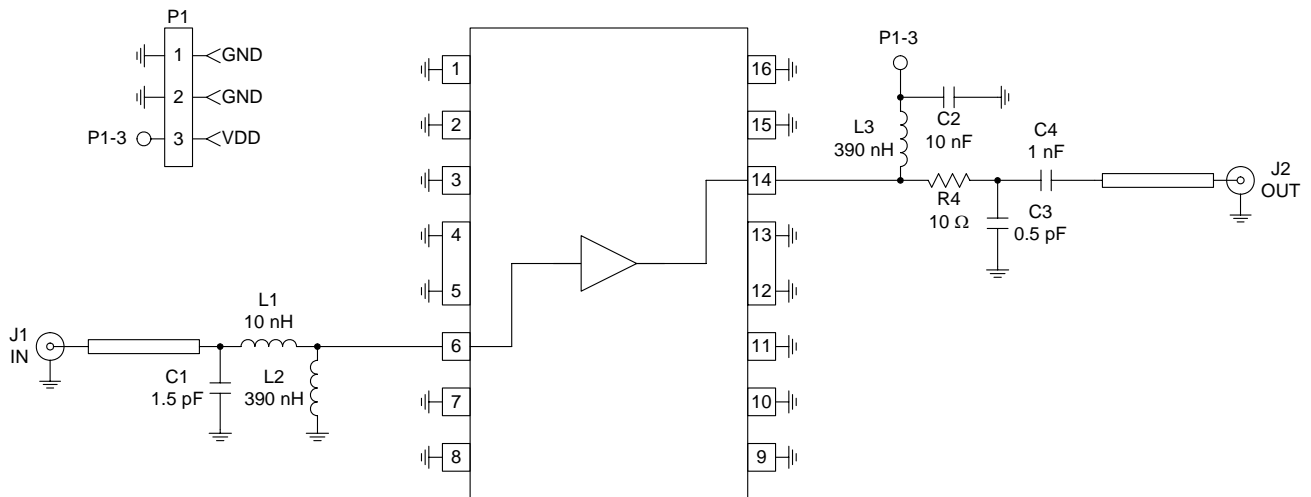

NOTES:
J1 and J2 are 75 ΩF connectors.

Drawing 2320401 Rev -

Evaluation Board Layout - 50Ω
Board Size 1.5" x 1.5"
Board Thickness 0.031", Board Material FR-4

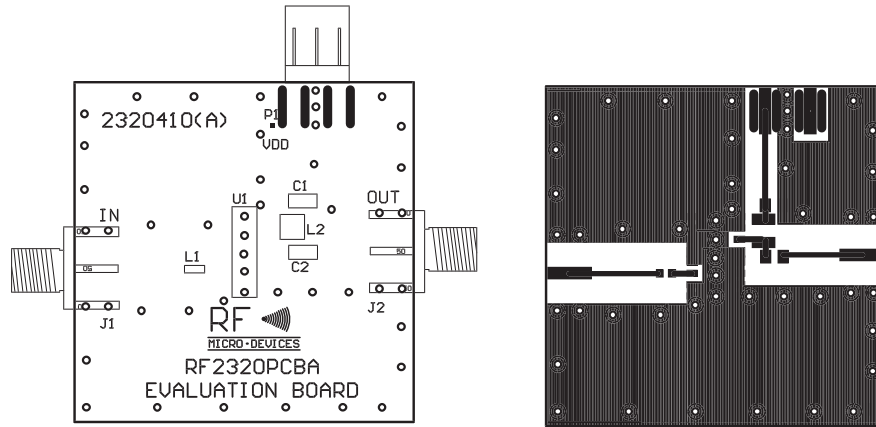

Evaluation Board Layout - 75Ω
Board Thickness 0.062", Board Material FR-4

