

阅读申明

- 1.本站收集的数据手册和产品资料都来自互联网，版权归原作者所有。如读者和版权方有任何异议请及时告之，我们将妥善解决。
- 2.本站提供的中文数据手册是英文数据手册的中文翻译，其目的是协助用户阅读，该译文无法自动跟随原稿更新，同时也可能存在翻译上的不当。建议读者以英文原稿为参考以便获得更精准的信息。
- 3.本站提供的产品资料，来自厂商的技术支持或者使用者的心得体会等，其内容可能存在描述上的差异，建议读者做出适当判断。
- 4.如需与我们联系，请发邮件到marketing@iczoom.com，主题请标有“数据手册”字样。

Read Statement

1. The datasheets and other product information on the site are all from network reference or other public materials, and the copyright belongs to the original author and original published source. If readers and copyright owners have any objections, please contact us and we will deal with it in a timely manner.
2. The Chinese datasheets provided on the website is a Chinese translation of the English datasheets. Its purpose is for reader's learning exchange only and do not involve commercial purposes. The translation cannot be automatically updated with the original manuscript, and there may also be improper translations. Readers are advised to use the English manuscript as a reference for more accurate information.
3. All product information provided on the website refer to solutions from manufacturers' technical support or users the contents may have differences in description, and readers are advised to take the original article as the standard.
4. If you have any questions, please contact us at marketing@iczoom.com and mark the subject with "Datasheets" .

Multilayer Diplexers

For GSM850/PCS Tx & Rx

DPX Series

Type: **DPX205850DT-4032A1 (2.0×1.25×0.95mm)**
 DPX201990DT-4114A2 (2.0×1.25×0.95mm)
 DPX201990DT-4014A2 (2.0×1.25×0.95mm)

Issue date: December 2010

- All specifications are subject to change without notice.
 - Conformity to RoHS Directive: This means that, in conformity with EU Directive 2002/95/EC, lead, cadmium, mercury, hexavalent chromium, and specific bromine-based flame retardants, PBB and PBDE, have not been used, except for exempted applications.
-

Multilayer Chip Diplexers For GSM850/PCS Tx & Rx

Conformity to RoHS Directive

DPX Series DPX205850DT-4032A1

SHAPES AND DIMENSIONS

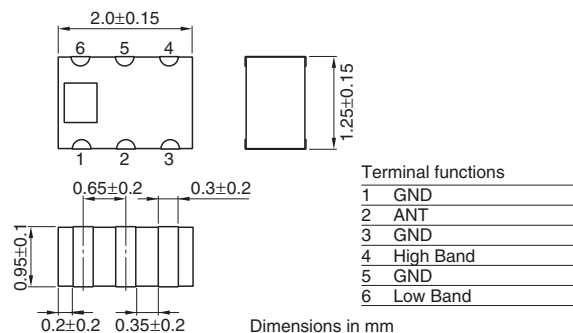

RECOMMENDED PC BOARD PATTERNS

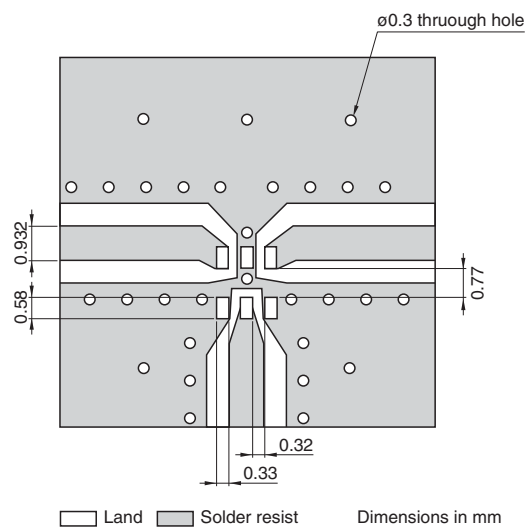

ELECTRICAL CHARACTERISTICS

Item	Port	Frequency range		Minimum value	Typical value	Maximum value
Insertion loss	ANT Lo-band	800 to 2170MHz	(dB)	—	1.51	3.0
	ANT Hi-band	2400 to 5850MHz	(dB)	—	1.36	3.0
Attenuation	ANT Lo-band	2400 to 5850MHz	(dB)	8.0	12.7	—
	ANT Hi-band	800 to 2170MHz	(dB)	8.0	11.5	—
Temperature range	Operating		(°C)	-40	—	+85
	Storage		(°C)	-40	—	+85

• Ta: +25°C

• Conformity to RoHS Directive: This means that, in conformity with EU Directive 2002/95/EC, lead, cadmium, mercury, hexavalent chromium, and specific bromine-based flame retardants, PBB and PBDE, have not been used, except for exempted applications.

• All specifications are subject to change without notice.

FREQUENCY CHARACTERISTICS

Lo-BAND PORT ATTENUATION S21

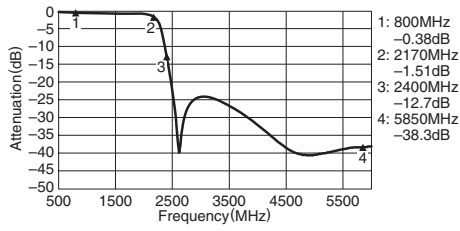

Hi-BAND PORT ATTENUATION S31

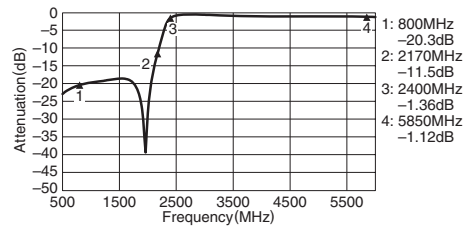

COMMON PORT RETURN LOSS S11

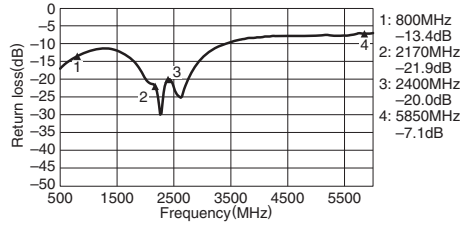

ISOLATION S23

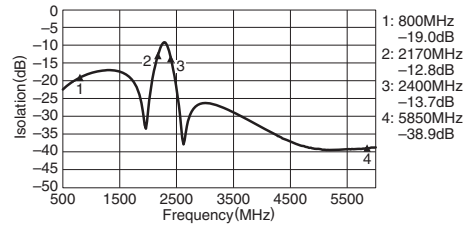

Lo-BAND PORT RETURN LOSS S22

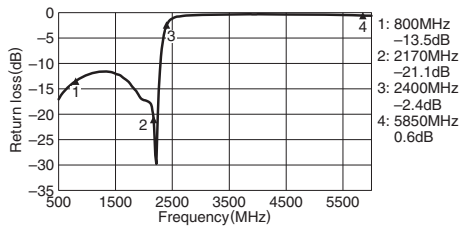

Hi-PORT RETURN LOSS S33

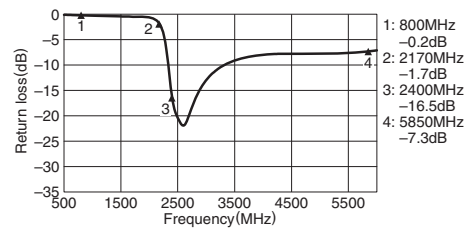

Multilayer Chip Diplexers For GSM850/PCS Tx & Rx

Conformity to RoHS Directive

DPX Series DPX201990DT-4114A2

SHAPES AND DIMENSIONS

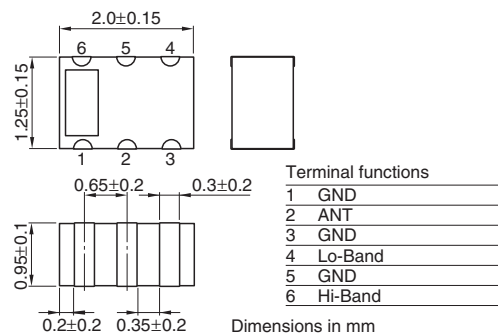

RECOMMENDED PC BOARD PATTERNS

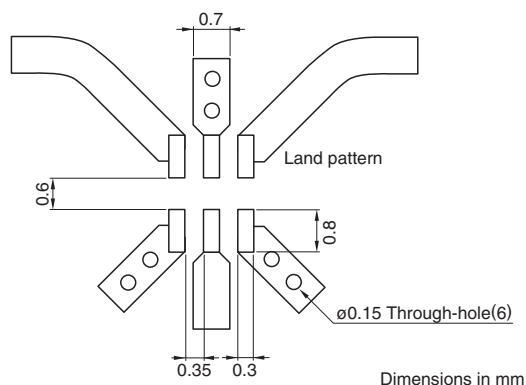

Line width be designed to match 50Ω characteristic impedance depending on PCB material and thickness.

ELECTRICAL CHARACTERISTICS

Item	Port	Frequency range	Minimum value	Typical value	Maximum value
Insertion loss	Lo-band	[−40 to +85°C] 824 to 894MHz	(dB) —	—	0.5
	Hi-band	[−40 to +85°C] 1850 to 1990MHz	(dB) —	—	0.55
	Lo-band	[25°C] 824 to 894MHz	(dB) —	—	0.45
	Hi-band	[25°C] 1850 to 1990MHz	(dB) —	—	0.5
Return loss	ANT	824 to 894, 1850 to 1990MHz	(dB) 10.0	—	—
	Hi-band	824 to 894MHz	(dB) 19.0	—	—
Attenuation	Lo-band	1850 to 1990MHz	(dB) 20.0	—	—
	Lo-band	1648 to 1788MHz(AGSM 2fo)	(dB) 10.0	—	—
	Lo-band	2472 to 2682MHz(AGSM 3fo)	(dB) 28.0	—	—
Power capability			(W) —	—	3.0
Temperature range		Operating	(°C) −40	—	+85
		Storage	(°C) −40	—	+85

• Conformity to RoHS Directive: This means that, in conformity with EU Directive 2002/95/EC, lead, cadmium, mercury, hexavalent chromium, and specific bromine-based flame retardants, PBB and PBDE, have not been used, except for exempted applications.

• All specifications are subject to change without notice.

FREQUENCY CHARACTERISTICS

Hi-BAND PORT S21

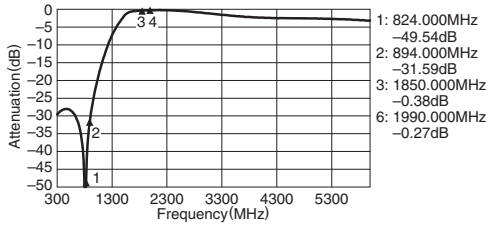

Lo-BAND PORT S31

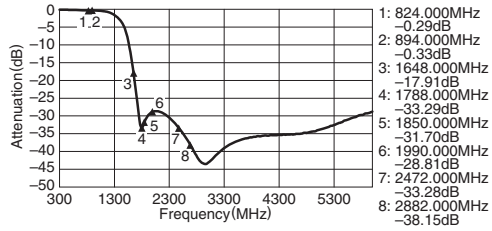

COMMON PORT RETURN LOSS S11

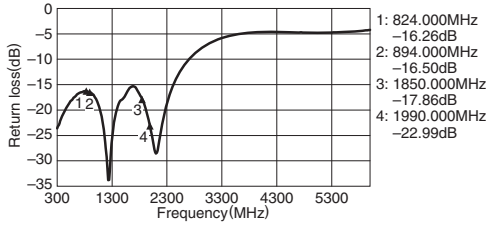

ISOLATION S23

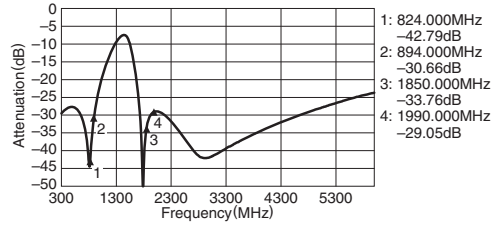

Hi-BAND PORT RETURN LOSS S22

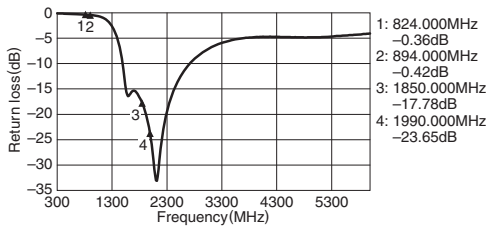

Lo-PORT RETURN LOSS S33

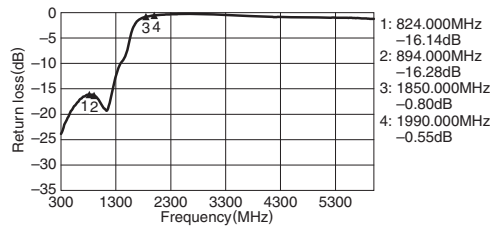

SMITH CHARTS

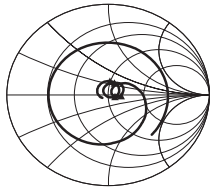

S11

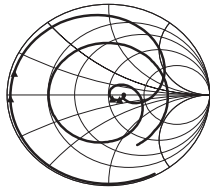

S22

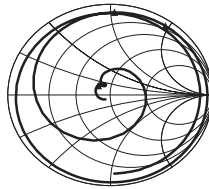

S33

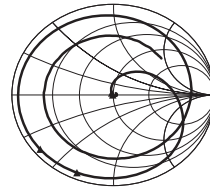

S21

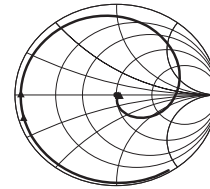

S31

Multilayer Chip Diplexers For AGSM/PCS Tx/Rx

Conformity to RoHS Directive

DPX Series DPX201990DT-4014A2

SHAPES AND DIMENSIONS

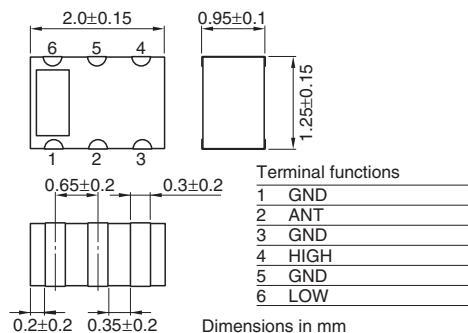

RECOMMENDED PC BOARD PATTERNS

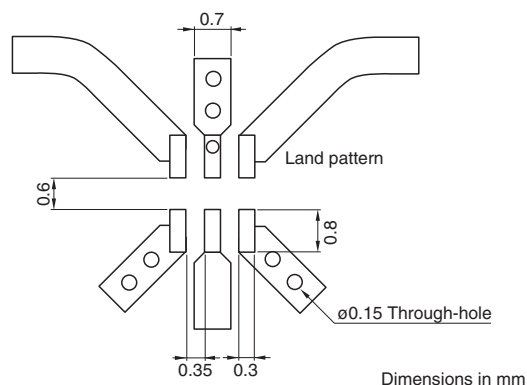

Line width be designed to match 50Ω characteristic impedance depending on PCB material and thickness.

ELECTRICAL CHARACTERISTICS

Item	Port	Frequency range	Minimum value	Typical value	Maximum value
Insertion loss	Lo-band	[−40 to +85°C] 824 to 894MHz	(dB) —	—	0.5
	Hi-band	[−40 to +85°C] 1850 to 1990MHz	(dB) —	—	0.55
	Lo-band	[25°C] 824 to 894MHz	(dB) —	—	0.45
	Hi-band	[25°C] 1850 to 1990MHz	(dB) —	—	0.5
Return loss	ANT	824 to 894, 1850 to 1990MHz	(dB) 10.0	—	—
	Hi-band	824 to 894MHz	(dB) 19.0	—	—
Attenuation	Lo-band	1850 to 1990MHz	(dB) 20.0	—	—
	Lo-band	1648 to 1788MHz(AGSM 2fo)	(dB) 10.0	—	—
	Lo-band	2472 to 2682MHz(AGSM 3fo)	(dB) 28.0	—	—
Power capability			(W) —	—	3.0
Temperature range		Operating	(°C) −40	—	+85
		Storage	(°C) −40	—	+85

• Conformity to RoHS Directive: This means that, in conformity with EU Directive 2002/95/EC, lead, cadmium, mercury, hexavalent chromium, and specific bromine-based flame retardants, PBB and PBDE, have not been used, except for exempted applications.

• All specifications are subject to change without notice.

FREQUENCY CHARACTERISTICS

Lo-BAND PORT S21

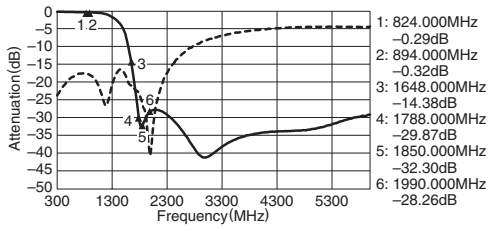

Hi-BAND PORT S31

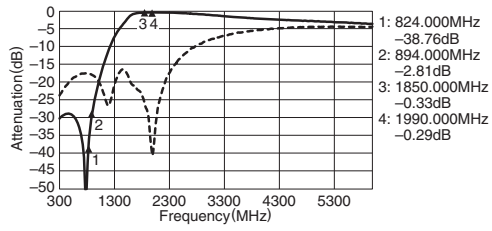

COMMON PORT RETURN LOSS S11

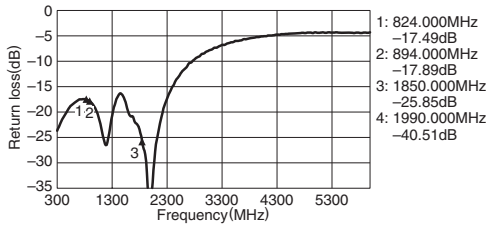

ISOLATION S23

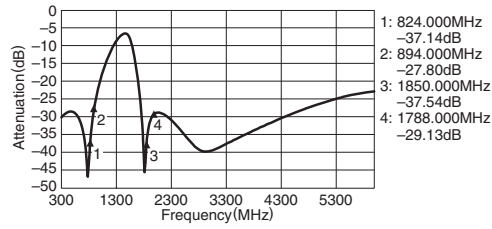

Lo-BAND PORT RETURN LOSS S22

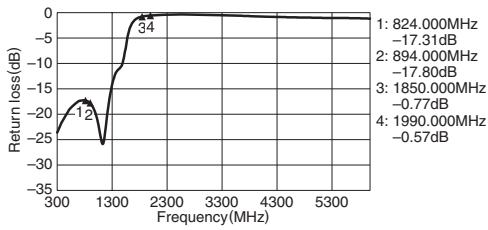

Hi-PORT RETURN LOSS S33

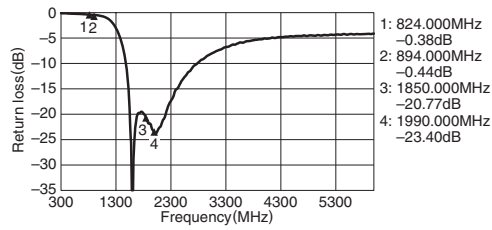

SMITH CHARTS

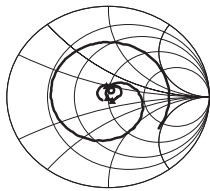

S11

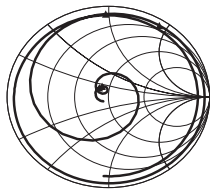

S22

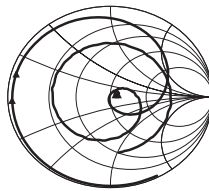

S33

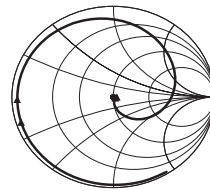

S21

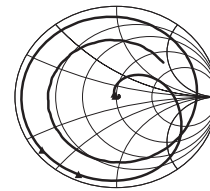

S31