

阅读申明

- 1.本站收集的数据手册和产品资料都来自互联网，版权归原作者所有。如读者和版权方有任何异议请及时告之，我们将妥善解决。
- 2.本站提供的中文数据手册是英文数据手册的中文翻译，其目的是协助用户阅读，该译文无法自动跟随原稿更新，同时也可能存在翻译上的不当。建议读者以英文原稿为参考以便获得更精准的信息。
- 3.本站提供的产品资料，来自厂商的技术支持或者使用者的心得体会等，其内容可能存在描述上的差异，建议读者做出适当判断。
- 4.如需与我们联系，请发邮件到marketing@iczoom.com，主题请标有“数据手册”字样。

Read Statement

1. The datasheets and other product information on the site are all from network reference or other public materials, and the copyright belongs to the original author and original published source. If readers and copyright owners have any objections, please contact us and we will deal with it in a timely manner.
2. The Chinese datasheets provided on the website is a Chinese translation of the English datasheets. Its purpose is for reader's learning exchange only and do not involve commercial purposes. The translation cannot be automatically updated with the original manuscript, and there may also be improper translations. Readers are advised to use the English manuscript as a reference for more accurate information.
3. All product information provided on the website refer to solutions from manufacturers' technical support or users the contents may have differences in description, and readers are advised to take the original article as the standard.
4. If you have any questions, please contact us at marketing@iczoom.com and mark the subject with "Datasheets" .

CLC5902

Dual Digital Tuner/AGC

General Overview

The CLC5902 Dual Digital Tuner/AGC IC is a two channel digital downconverter (DDC) with integrated automatic gain control (AGC). The CLC5902 is a key component in the Diversity Receiver Chipset (DRCS) which includes one CLC5902 Dual Digital Tuner/AGC, two CLC5957 12-bit analog-to-digital converters (ADCs), and two CLC5526 digitally controlled variable gain amplifiers (DVGAs). A block diagram for a Diversity Receiver Chipset based narrowband communications system is shown in Figure 1. This system allows direct IF sampling of signals up to 300MHz for enhanced receiver performance and reduced system costs.

The CLC5902 offers high dynamic range digital tuning and filtering based on hard-wired digital signal processing (DSP) technology. Each channel has independent tuning, phase offset, and gain settings. Channel filtering is performed by a series of three filters. The first is a 4-stage Cascaded Integrator Comb (CIC) filter with a programmable decimation ratio from 8 to 2048. Next there are two symmetric FIR filters, a 21-tap and a 63-tap, both with programmable coefficients. The first FIR filter decimates the data by 2, the second FIR decimates by either 2 or 4. Channel filter bandwidth at 52MSPS ranges from $\pm 650\text{kHz}$ down to $\pm 1.3\text{kHz}$.

The CLC5902's AGC controller monitors the ADC output and controls the ADC input signal level by adjusting the DVGA setting. AGC threshold, deadband+hysteresis, and the loop time constant are user defined. Total dynamic range of greater than 120dB full-scale signal to noise can be achieved with the Diversity Receiver Chipset.

Features

- 52MSPS Operation
- Two Independent Channels with 14-bit inputs
- Greater than 100 dB image rejection
- Greater than 100 dB spurious free dynamic range
- 0.02 Hz tuning resolution
- User Programmable AGC
- Channel Filters include a Fourth Order CIC followed by 21-tap and 63-tap Symmetric FIRs
- FIR filters process 21-bit Data with 16-bit Programmable Coefficients
- Flexible output formats include 12-bit Floating Point or 8, 16, 24, and 32 bit Fixed Point
- Serial and Parallel output ports
- JTAG Boundary Scan
- 8-bit Microprocessor Interface
- 380mW/channel, 52 MHz, 3.3V
- 128 pin PQFP package

Applications

- Cellular Basestations
- Satellite Receivers
- Wireless Local Loop Receivers
- Digital Communications

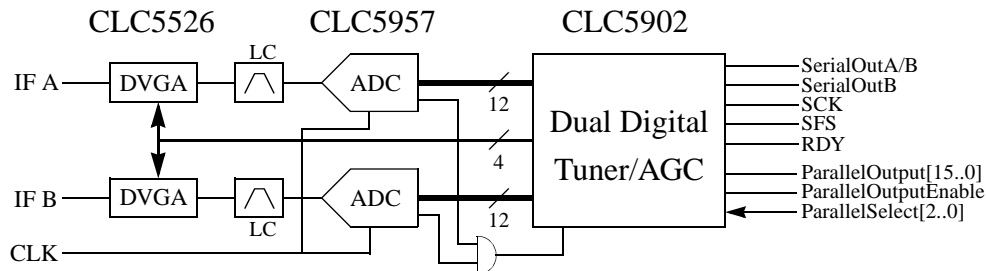
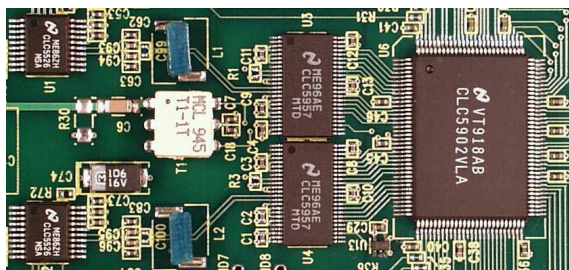

Figure 1 Diversity Receiver Chipset Block Diagram

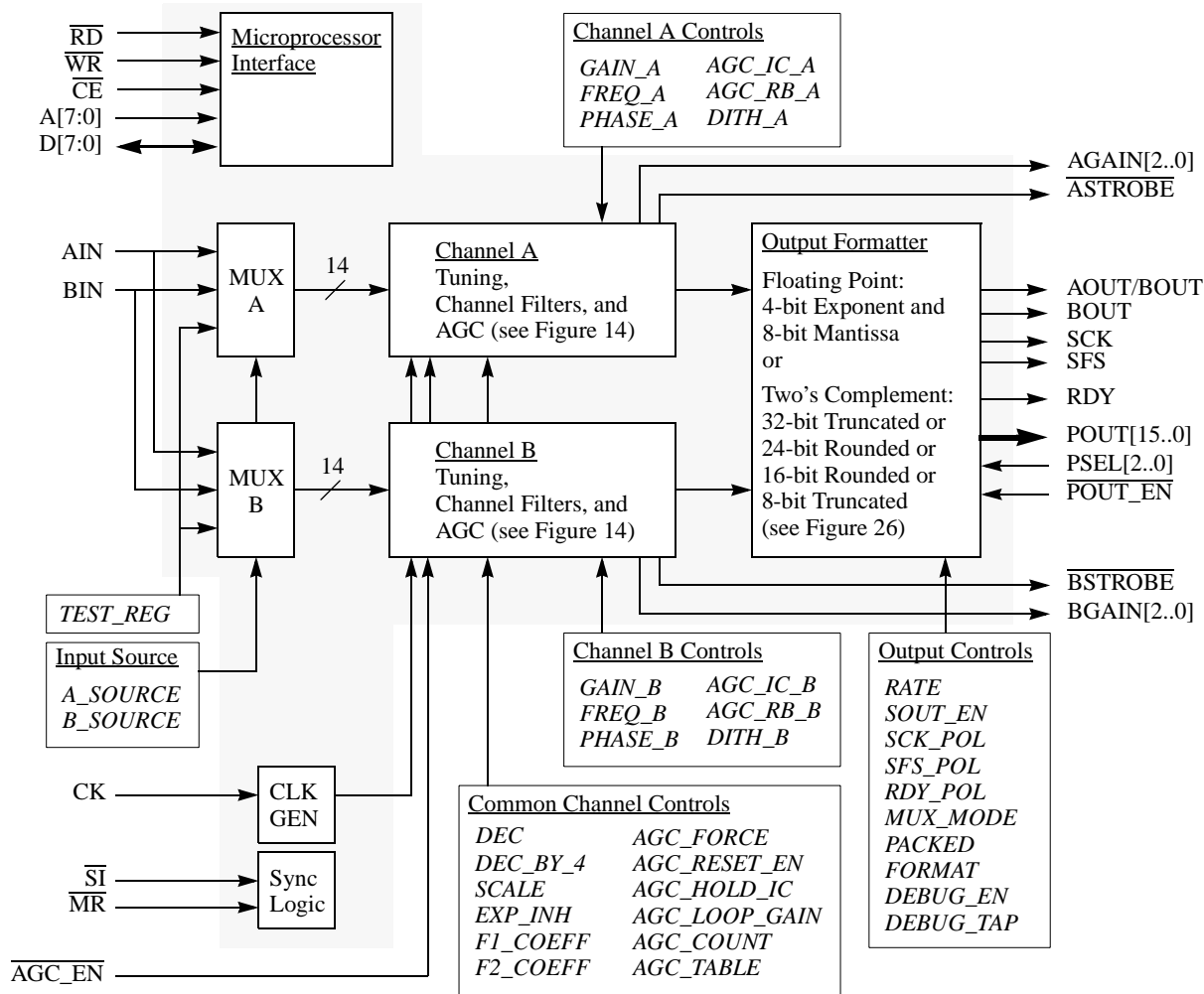

Figure 2 CLC5902 Dual Digital Tuner/AGC Block Diagram with Control Register Associations

Functional Description.

The CLC5902 block diagram is shown in Figure 2. The CLC5902 contains two identical digital down-conversion (DDC) circuits. Each DDC accepts a 14-bit sample at up to 52MSPS, down converts from a selected carrier frequency to baseband, decimates the signal rate by a programmable factor ranging from 32 to 16384, provides channel filtering, and outputs quadrature symbols.

A crossbar switch enables either of the two inputs or a test register to be routed to either DDC channel. Flexible channel filtering is provided by the two programmable decimating FIR filters. The final filter outputs can be converted to a 12-bit floating point format or standard two's complement format. The output data is available at both serial and parallel ports.

The CLC5902 maintains over 100 dB of spurious free dynamic range and over 100 dB of out-of-band rejection. This allows considerable latitude in channel filter partitioning between the analog and digital domains.

The frequencies, phase offsets, and phase dither of the two sine/cosine numerically controlled oscillators (NCOs) can be independently specified. Both channels share the same

decimation ratio, bandwidth, filter coefficients, and input/output formats.

Each channel has its own AGC circuit for use with narrowband radio channels where most of the channel filtering precedes the ADC. The AGC closes the loop around the CLC5526 DVGA, compressing the dynamic range of the signal into the ADC. The AGC can be configured to operate continuously or in a gated mode. The two AGC circuits operate independently but share the same programmed parameters and control signals.

The chip receives configuration and control information over a microprocessor-compatible bus consisting of an 8-bit data I/O port, an 8-bit address port, a chip enable strobe, a read strobe, and a write strobe. The chip's control registers (8 bits each) are memory mapped into the 8-bit address space of the control port.

JTAG boundary scan and on-chip diagnostic circuits are provided to simplify system debug and test.

The CLC5902 supports 3.3V I/O. The CLC5957 ADC outputs are compatible with the CLC5902 inputs. The CLC5902 outputs swing to the 3.3V rail so they can be directly connected to 5V TTL inputs if desired.

CLC5902 Electrical Characteristics

($V_{CC}=+3.3V$, 52MHz, CIC Decimation=48, F2 Decimation=2, $T_{min}=-40^{\circ}C$, $T_{max}=+85^{\circ}C$; unless specified)

DC Characteristics

PARAMETER	SYMBOL	MIN	TYP	MAX	UNITS	Notes
Voltage input low	V_{IL}	-0.5		0.8	V	1
Voltage input high	V_{IH}	2.0		$V_{CC}+0.5$	V	1
Input current	I_{IN}			10	μA	1
Voltage output low ($I_{OL} = 4mA/12mA$, see pin description)	V_{OL}			0.4	V	1
Voltage output high ($I_{OH} = -4mA/-12mA$, see pin description)	V_{OH}	2.4			V	1
Input capacitance	C_{IN}			4.0	pF	3

AC Characteristics

PARAMETER ($C_L=50pF$)	SYMBOL	MIN	TYP	MAX	UNITS	Notes
Clock (CK) Frequency (Figure 7)	F_{CK}			52	MHz	1
Spurious Free Dynamic Range	SFDR		-100		dBFS	
Signal to Noise Ratio	SNR		-127		dBFS	
Tuning Resolution			0.02		Hz	
Phase Resolution			0.005		$^{\circ}$	
\overline{MR} Active Time (Figure 5)	t_{MRA}	4			CK periods	1
\overline{MR} Inactive to first Control Port Access (Figure 5)	t_{MRIC}	10			CK periods	1
\overline{MR} Setup Time to CK (Figure 5)	t_{MRSU}	9			ns	1
\overline{MR} Hold Time to CK (Figure 5)	t_{MRH}	2			ns	1
\overline{MR} Inactive to $A B\overline{STROBE}$ Release (Figure 5)	t_{MRSR}		17		ns	
\overline{SI} Setup Time to CK (Figure 6)	t_{SISU}	9			ns	1
\overline{SI} Hold Time from CK (Figure 6)	t_{SIH}	2			ns	1
\overline{SI} Pulse Width (Figure 6)	t_{SIW}	4			CK periods	1
\overline{SI} Inactive to $A B\overline{STROBE}$ Release (Figure 6)	t_{SISR}		17		ns	
CK duty cycle (Figure 7)	t_{CKDC}	40		60	%	1
CK rise and fall times (V_{IL} to V_{IH}) (Figure 7)	t_{RF}			3	ns	1
Input setup before CK goes high ($A B\overline{IN}$) (Figure 7)	t_{SU}	7			ns	1
Input hold time after CK goes high (Figure 7)	t_{HD}	3			ns	1
$A B\overline{STROBE}$ Pulse Width (Figure 8)	t_{STBPW}		1		CK period	2
$A B\overline{GAIN}$ Valid Setup before $A B\overline{STROBE}$ (Figure 8)	t_{GSU}		1		CK period	2
AGC_EN Active Width (Figure 8)	t_{ENW}	2			CK periods	1
SCK to SFS Valid (Table Note A) (Figure 9)	t_{SFSV}	0		7	ns	1
SCK to $A B\overline{OUT}$ Valid (Table Note B) (Figure 9)	t_{OV}	0		7	ns	1
RDY Pulse Width (Figure 9)	t_{RDYW}		4		CK periods	1
POUT_EN Active to POUT[15..0] Valid (Figure 10)	t_{OENV}			15	ns	1
POUT_EN Inactive to POUT[15..0] Tri-State (Figure 10)	t_{OENT}			15	ns	1
PSEL[2..0] to POUT[15..0] Valid (Figure 11)	t_{SELV}			20	ns	1
RDY to POUT[15..0] New Value Valid (Table Note C) (Figure 12)	t_{RDYV}			10	ns	1
Propagation Delay TCK to TDO (Figure 13)	t_{PLH}			30	ns	1
Propagation Delay TCK to Data Out (Figure 13)	t_{PHL}			35	ns	1
Disable Time TCK to TDO (Figure 13)	t_{PLZ}			35	ns	1
Disable Time TCK to Data Out (Figure 13)	t_{PHZ}			35	ns	1
Enable Time TCK to TDO (Figure 13)	t_{PZL}	0		35	ns	1

PARAMETER (C _L =50pF)	SYMBOL	MIN	TYP	MAX	UNITS	Notes
Enable Time TCK to Data Out (Figure 13)	t _{PZH}	0		35	ns	1
Setup Time Data to TCK (Figure 13)	t _S	10			ns	1
Setup Time TDI to TCK (Figure 13)	t _S	10			ns	1
Setup Time TMS to TCK (Figure 13)	t _S	15			ns	1
Hold Time Data to TCK (Figure 13)	t _H	55			ns	1
Hold Time TCK to TDI (Figure 13)	t _H	55			ns	1
Hold Time TCK to TMS (Figure 13)	t _H	10			ns	1
TCK Pulse Width High (Figure 13)	t _{WH}	55			ns	1
TCK Pulse Width Low (Figure 13)	t _{WL}	40			ns	1
TCK Maximum Frequency (Figure 13)	JTAG _{FMAX}			10	MHz	1
Control Setup before the controlling signal goes low (Figure 14)	t _{CSU}	5			ns	1
Control hold after the controlling signal goes high (Figure 14)	t _{CHD}	5			ns	1
Controlling strobe pulse width (Write) (Figure 14)	t _{CSPW}	30			ns	1
Control output delay controlling signal low to D (Read) (Figure 14)	t _{CDLY}			30	ns	1
Control tri-state delay after controlling signal goes high (Figure 14)	t _{CZ}			20	ns	1
Dynamic Supply Current (F _{CK} =52MHz, N=48)	I _{CC}		230	280	mA	1
Dynamic Supply Current (F _{CK} =52MHz, N=8)	I _{CC}		260	320	mA	1

Notes A - C

- A. t_{SFSV} refers to the rising edge of **SCK** when SCK_POL=0 and the falling edge when SCK_POL=1.
- B. t_{OV} refers to the rising edge of **SCK** when SCK_POL=0 and the falling edge when SCK_POL=1.
- C. t_{RDYV} refers to the rising edge of **RDY** when RDY_POL=0 and the falling edge when RDY_POL=1.

Notes 1 - 3

- These parameters are 100% tested at 25°C.
- Typical specifications are the mean values of the distributions of deliverable CLC5902s tested to date.
- Min/max ratings are based on product characterization and simulation. Individual parameters are tested as noted. Outgoing quality levels are determined from tested parameters.

Absolute Maximum Ratings

Positive Supply Voltage (VCC)	-0.3V to 4.2V
Voltage on Any Input or Output Pin	-0.3V to VCC+0.5V
Input Current at Any Pin	±25mA
Package Input Current	±50mA
Package Dissipation at TA=25°C	1W
ESD Susceptibility	
Human Body Model	1500V
Machine Model	100V
Soldering Temperature, Infrared, 10 seconds	300°C
Storage Temperature	-65°C to 150°C

NOTE: Absolute maximum ratings are limiting values, to be applied individually, and beyond which the serviceability of the circuit may be impaired. Functional operability under any of these conditions is not nec-

essarily implied. Exposure to maximum ratings for extended periods may affect device reliability.

Recommended Operating Conditions

Positive Supply Voltage (VCC)	3.3V ±10%
Operating Temperature Range	-40°C to +85°C

Package Thermal Resistance

Package	θ _{ja}	θ _{jc}
128 pin PQFP	39°C/W	TBD°C/W

Reliability Information

Transistor Count	1.2 million
------------------	-------------

Ordering Information

Order Code	Temperature Range	Description
CLC5902VLA	-40°C to +85°C	128-pin PQFP (industrial temperature range)
CLC-DRCS-PCASM		Fully loaded Diversity Receiver Chipset evaluation board and control panel software.
CLC-CAPT-PCASM		Data Capture board for the DRCS with Matlab analysis routines.

Package Dimensions

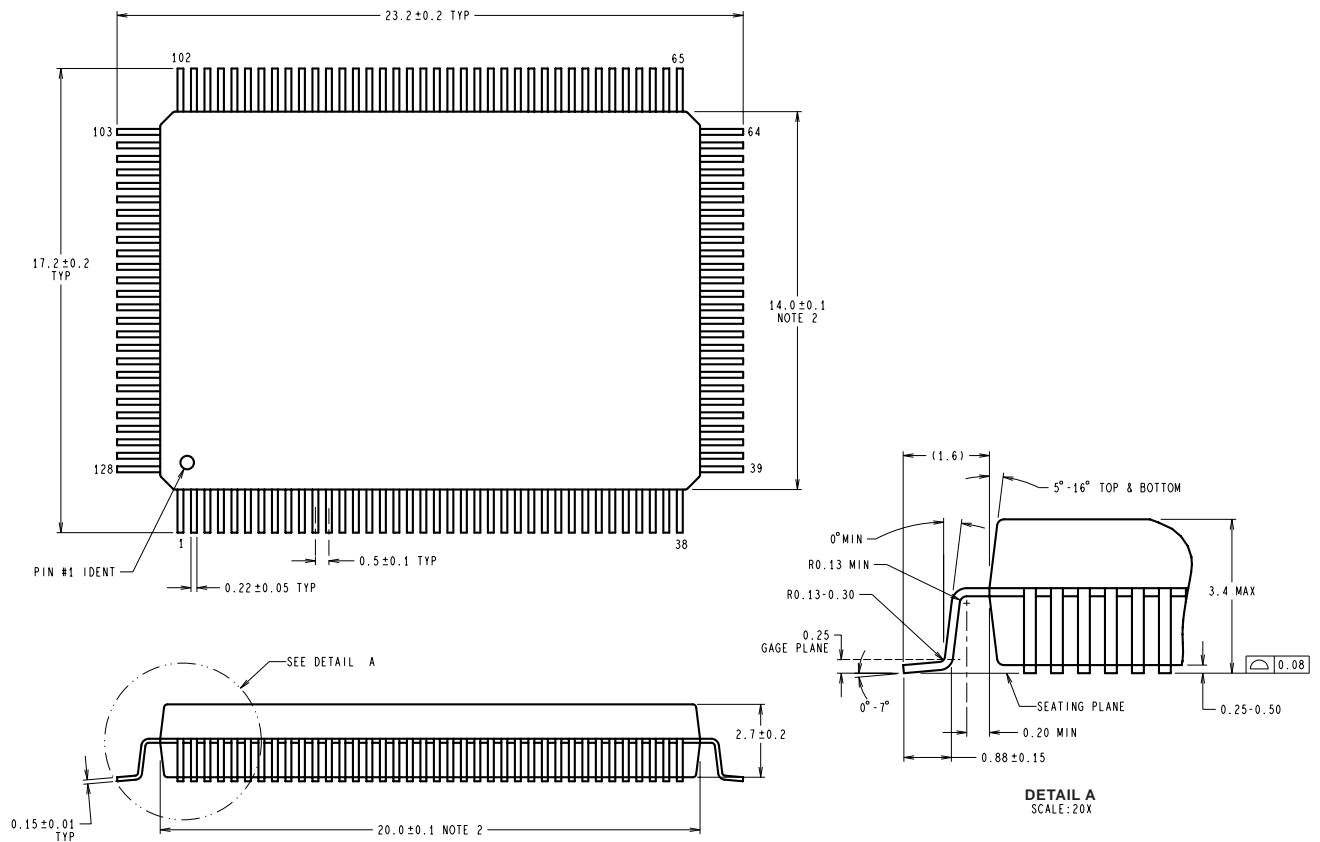

NOTES: UNLESS OTHERWISE SPECIFIED

Dimension are in millimeters

- STANDARD LEAD FINISH:
7.62 MICROMETERS MINIMUM SOLDER PLATING (85/15)
THICKNESS ON COPPER.
- DIMENSION DOES NOT INCLUDE MOLD PROTRUSION.
MAXIMUM ALLOWABLE MOLD PROTRUSION 0.25mm PER SIDE.
- REFERENCE ASAT DWG# DG2003, DATED 07/09/93.

Figure 3 CLC5902 Package Dimensions

Pin Descriptions

Signal	Pin	DESCRIPTION
$\overline{\text{MR}}$	45	MASTER RESET, <i>Active low</i> Resets all registers within the chip. $\overline{\text{ASTROBE}}$ and $\overline{\text{BSTROBE}}$ are asserted during $\overline{\text{MR}}$.
AIN[13:0], BIN[13:0]	4:10,12:18 22:28,30:36	INPUT DATA, <i>Active high</i> 2's complement input data. AIN[13] and BIN[13] are the MSBs. The data is clocked into the chip on the rising edge of the clock (CK). The CLC595X connects directly to these input pins with no additional logic.
AOUT BOUT (12mA drive)	82 78	SERIAL OUTPUT DATA, <i>Active high</i> The 2's complement serial output data is transmitted on these pins, MSB first. The output bits change on the rising edge of SCK (falling edge if SCK_POL=1) and should be captured on the falling edge of SCK (rising if SCK_POL=1). These pins are tri-stated at power up and are enabled by the SOUT_EN control register bit. See Figure 9 and Figure 29 timing diagrams. In Debug Mode AOUT=DEBUG[1] , BOUT=DEBUG[0] .
AGAIN[2:0], BGAIN[2:0]	125:127 40:42	OUTPUT DATA TO DVGA, <i>Active high</i> 3 bit bus that sets the gain of the DVGA determined by the AGC circuit.
$\overline{\text{ASTROBE}}$, $\overline{\text{BSTROBE}}$	124 43	DVGA STROBE, <i>Active low</i> Strobes the data into the DVGA. See Figure 8 and Figure 33 timing diagrams.
SCK (12mA drive)	80	SERIAL DATA CLOCK, <i>Active high or low</i> The serial data is clocked out of the chip by this clock. The active edge of the clock is user programmable. This pin is tri-stated at power up and is enabled by the SOUT_EN control register bit. See Figure 9 and Figure 29 timing diagrams. In Debug Mode outputs an appropriate clock for the debug data.
SFS (12mA drive)	81	SERIAL FRAME STROBE, <i>Active high or low</i> The serial word strobe. This strobe delineates the words within the serial output streams. This strobe is a pulse at the beginning of each serial word (PACKED=0) or each serial word I/Q pair (PACKED=1). The polarity of this signal is user programmable. This pin is tri-stated at power up and is enabled by the SOUT_EN control register bit. See Figure 9 and Figure 29 timing diagrams. In Debug Mode SFS=DEBUG[2] .
POUT[15:0] (12mA drive)	84,86:88,90,91, 93:97,104:106, 108,109	PARALLEL OUTPUT DATA, <i>Active high</i> The output data is transmitted on these pins in parallel format. The POUT_SEL[2..0] pins select one of eight 16-bit output words. The POUT_EN pin enables these outputs. POUT[15] is the MSB. In Debug Mode POUT[15..0]=DEBUG[19..4] .
POUT_SEL[2:0]	112:114	PARALLEL OUTPUT DATA SELECT, <i>Active high</i> The 16-bit output word is selected with these 3 pins according to Table 3. Not used in Debug Mode.
$\overline{\text{POUT_EN}}$	111	PARALLEL OUTPUT ENABLE. <i>Active low</i> This pin enables the chip to output the selected output word on the POUT[15:0] pins. Not used in Debug Mode.
RDY (12mA drive)	77	READY FLAG, <i>Active high or low</i> The chip asserts this signal to identify the beginning of an output sample period (OSP). The polarity of this signal is user programmable. This signal is typically used as an interrupt to a DSP chip, but can also be used as a start pulse to dedicated circuitry. This pin is active regardless of the state of SOUT_EN. In Debug Mode RDY=DEBUG[3] .
CK	20	INPUT CLOCK. <i>Active high</i> The clock input to the chip. The AIN , BIN , and $\overline{\text{SI}}$ input signals are clocked into the chip on the rising edge of this clock.
$\overline{\text{SI}}$	46	SYNC IN. <i>Active low</i> The sync input to the chip. The decimation counters, dither, and NCO phase can be synchronized by $\overline{\text{SI}}$. This sync is clocked into the chip on the rising edge of the input clock (CK). Tie this pin high if external sync is not required. All sample data is flushed by $\overline{\text{SI}}$. To properly initialize the DVGA ASTROBE and BSTROBE are asserted during $\overline{\text{SI}}$.
D[7:0] (12mA drive)	62,63,69:73,75	DATA BUS. <i>Active high</i> This is the 8 bit control data I/O bus. Control register data is loaded into the chip or read from the chip through these pins. The chip will only drive output data on these pins when CE is low, RD is low, and WR is high.

Table 1 CLC5902 Pin Descriptions

Signal	Pin	DESCRIPTION
A[7:0]	48,50,52:57	ADDRESS BUS. <i>Active high</i> These pins are used to address the control registers within the chip. Each of the control registers within the chip are assigned a unique address in a flat address space. A control register can be written to or read from by setting A[7:0] to the register's address.
$\overline{\text{RD}}$	59	READ ENABLE. <i>Active low</i> This pin enables the chip to output the contents of the selected register on the D[7:0] pins when $\overline{\text{CE}}$ is also low.
$\overline{\text{WR}}$	58	WRITE ENABLE. <i>Active low</i> This pin enables the chip to write the value on the D[7:0] pins into the selected register when $\overline{\text{CE}}$ is also low. This pin can also function as RD / $\overline{\text{WR}}$ if RD is held low.
$\overline{\text{CE}}$	60	CHIP ENABLE. <i>Active low</i> This control strobe enables the read or write operation. The contents of the register selected by A[7:0] will be output on D[7:0] when $\overline{\text{RD}}$ is low and $\overline{\text{CE}}$ is low. If $\overline{\text{WR}}$ is low and $\overline{\text{CE}}$ is low, then the selected register will be loaded with the contents of D[7:0] .
$\overline{\text{AGC_EN}}$	44	AGC ENABLE. <i>Active low</i> When enabled this pin starts the AGC counter. The AGC will operate until the counter decrements to zero then the AGC holds the last setting.
TDO	116	TEST DATA OUT. <i>Active high</i>
TDI	117	TEST DATA IN. <i>Active high with pull-up</i>
TMS	118	TEST MODE SELECT. <i>Active high with pull-up</i>
TCK	119	TEST CLOCK. <i>Active high</i>
$\overline{\text{TRST}}$	121	RESET. <i>Active low with pull-up</i> Asynchronous reset for TAP controller. Tie low or to $\overline{\text{MR}}$ if JTAG is not used.
$\overline{\text{SCAN_EN}}$	122	SCAN ENABLE. <i>Active low with pull-up</i> Enables access to internal scan registers. Tie high. Used for manufacturing test only!
VSS	3,19,29,37,47,51, 61,68,76,83,89, 98,103,110,120	Ground. Quantity 15.
VDD	11,21,39,49,64, 74,79,85,92,107, 115,128	Power. Quantity 12.

Table 1 CLC5902 Pin Descriptions

Timing Diagrams

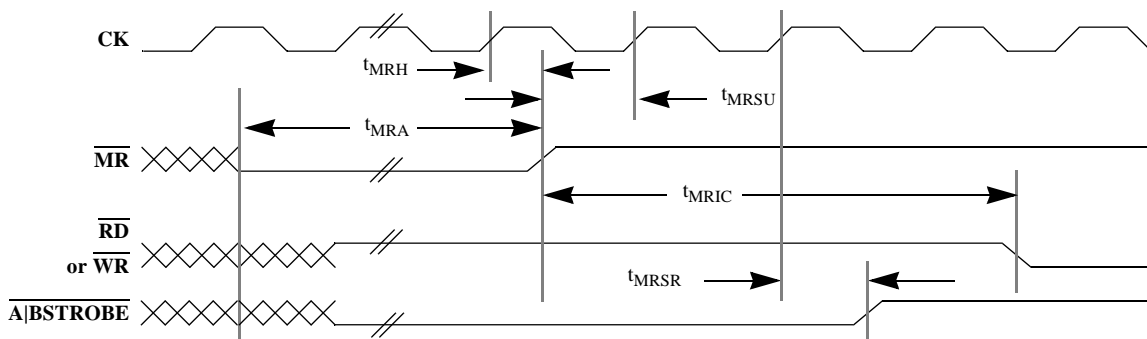

Figure 5 CLC5902 Master Reset Timing

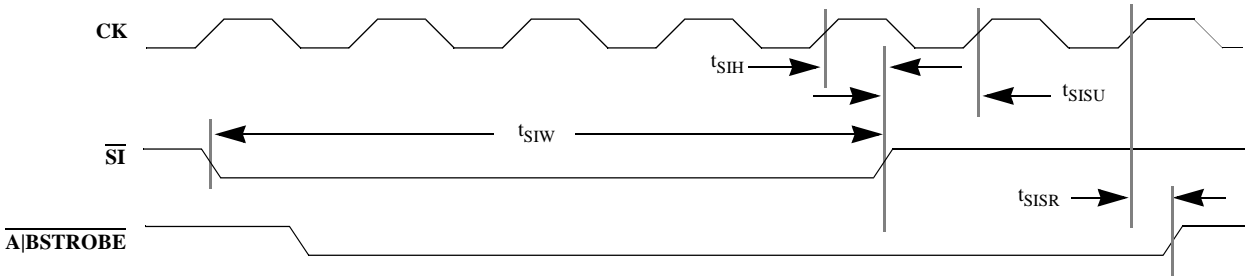

Figure 6 CLC5902 Synchronization Input (\overline{SI}) Timing

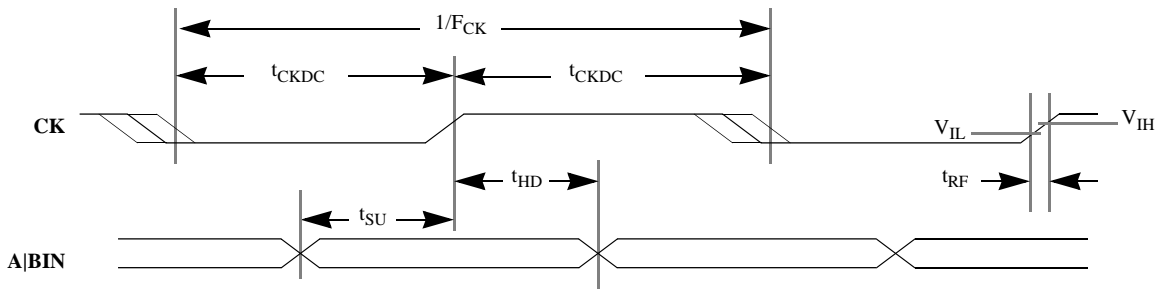

Figure 7 CLC5902 ADC Input and Clock Timing

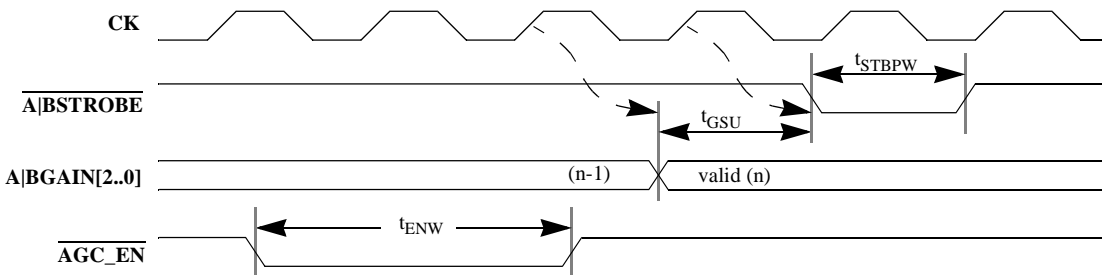

Figure 8 CLC5902 DVGA Interface Timing

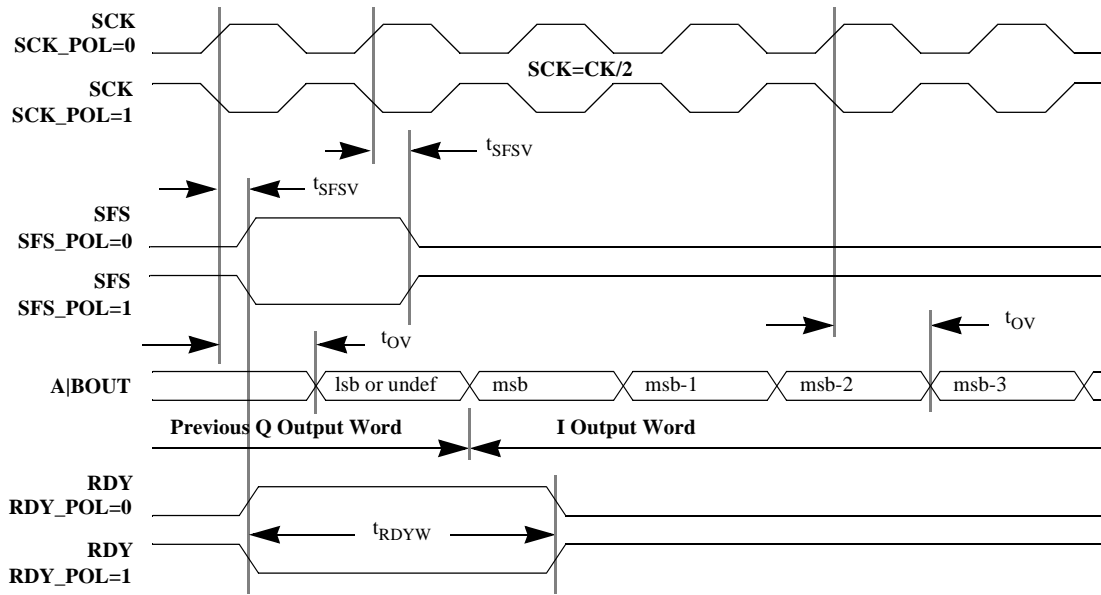

Figure 9 CLC5902 Serial Port Timing

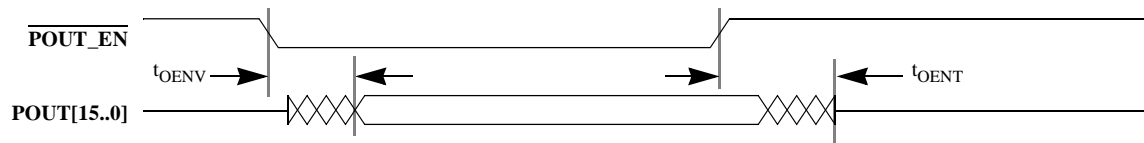

Figure 10 CLC5902 Parallel Output Enable Timing

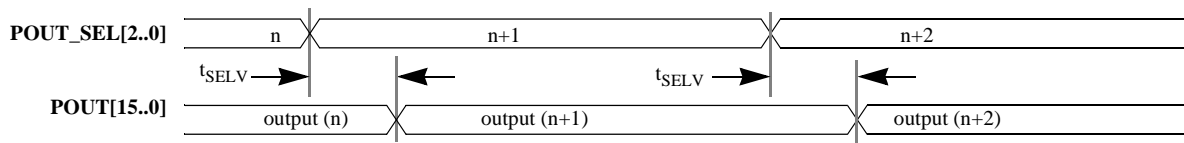

Figure 11 CLC5902 Parallel Output Select Timing

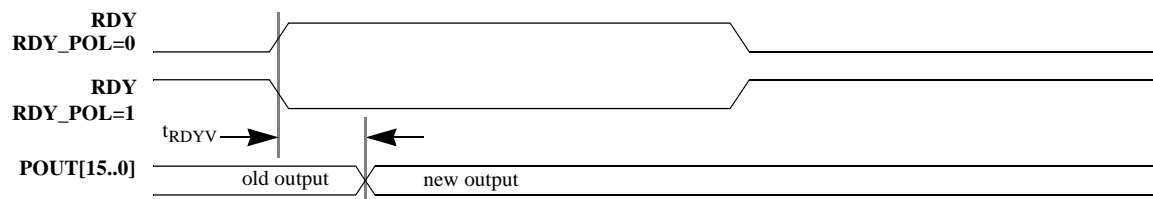

Figure 12 CLC5902 Parallel Output Data Ready Timing

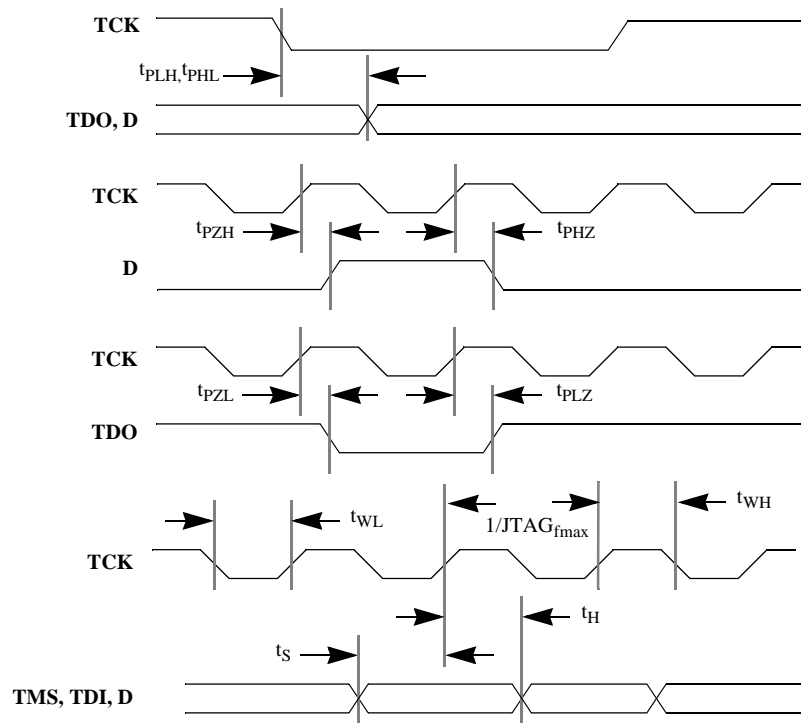

Figure 13 CLC5902 JTAG Port Timing

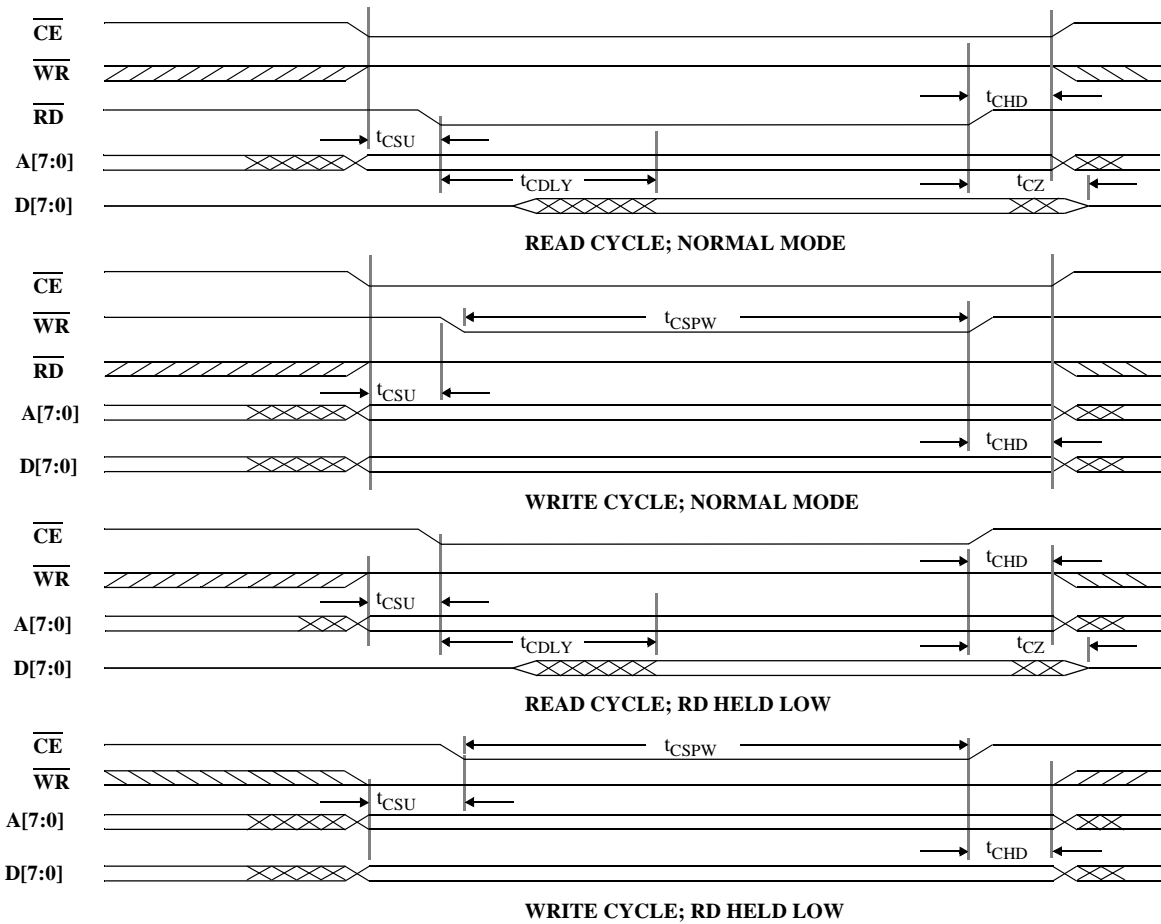

Figure 14 CLC5902 Control I/O Timing

Detailed Description

Control Interface

The CLC5902 is configured by writing control information into 148 control registers within the chip. The contents of these control registers and how to use them are described in Table 5. The registers are written to or read from using the **D[7:0]**, **A[7:0]**, **CE**, **RD** and **WR** pins (see Table 1 for pin descriptions). This interface is designed to allow the CLC5902 to appear to an external processor as a memory mapped peripheral. See Figure 14 for details.

The control interface is asynchronous with respect to the system clock, **CK**. This allows the registers to be written or read at any time. In some cases this might cause an invalid operation since the interface is not internally synchronized. In order to assure correct operation, **SI** must be asserted after the control registers are written.

The **D[7:0]**, **A[7:0]**, **WR**, **RD** and **CE** pins should not be driven above the positive supply voltage.

Master Reset

A master reset pin, **MR**, is provided to initialize the CLC5902 to a known condition and should be strobed after power up. This signal will clear all sample data and all user programmed data (filter coefficients and AGC settings). All outputs will be disabled (tri-stated). **ASTROBE** and **BSTROBE** will be asserted to initialize the DVGA values. Table 5 describes the control register default values.

Synchronizing Multiple CLC5902 Chips

A system containing two or more CLC5902 chips will need to be synchronized if coherent operation is desired. To synchronize multiple CLC5902 chips, connect all of the sync input pins together so they can be driven by a common sync strobe. Synchronization occurs on the rising edge of **CK** when **SI** goes back high. When **SI** is asserted all sample data will be flushed immediately, the numerically controlled oscillator (NCO) phase offset will be ini-

tialized, the NCO dither generators will be reset, and the CIC decimation ratio will be initialized. Only the configuration data loaded into the microprocessor interface remains unaffected.

SI may be held low as long as desired after a minimum of 4 **CK** periods.

Input Source

The input crossbar switch allows either **AIN**, **BIN**, or a test register to be routed to the channel A or channel B AGC/DDC. The AGC outputs, **AGAIN** and **BGAIN**, are not switched. If **AIN** and **BIN** are exchanged the AGC loop will be open and the AGCs will not function properly. **AIN** and **BIN** should meet the timing requirements shown in Figure 7.

Selecting the test register as the input source allows the AGC or DDC operation to be verified with a known input. See the test and diagnostics section for further discussion.

Down Converters

A detailed block diagram of each DDC channel is shown in Figure 15. Each down converter uses a complex NCO and mixer to quadrature downconvert a signal to base-band. The “FLOAT TO FIXED CONVERTER” treats the 15-bit mixer output as a mantissa and the AGC output, **EXP**, as a 3-bit exponent. It performs a bit shift on the data based on the value of **EXP**. This bit shifting is used to expand the compressed dynamic range resulting from the DVGA operation. The DVGA gain is adjusted in 6dB steps which are equivalent to each digital bit shift.

The exponent (**EXP**) can be forced to its maximum value by setting the **EXP_INH** bit. If $x_{in}(n)$ is the DDC input, the signal after the “FLOAT TO FIXED CONVERTER” is

$$x_3(n) = x_{in}(n) \cdot \cos(\omega n) \cdot 2^{EXP} \quad \text{EQ. 1}$$

for the I component. Changing the ‘cos’ to ‘sin’ in this equation will provide the Q component.

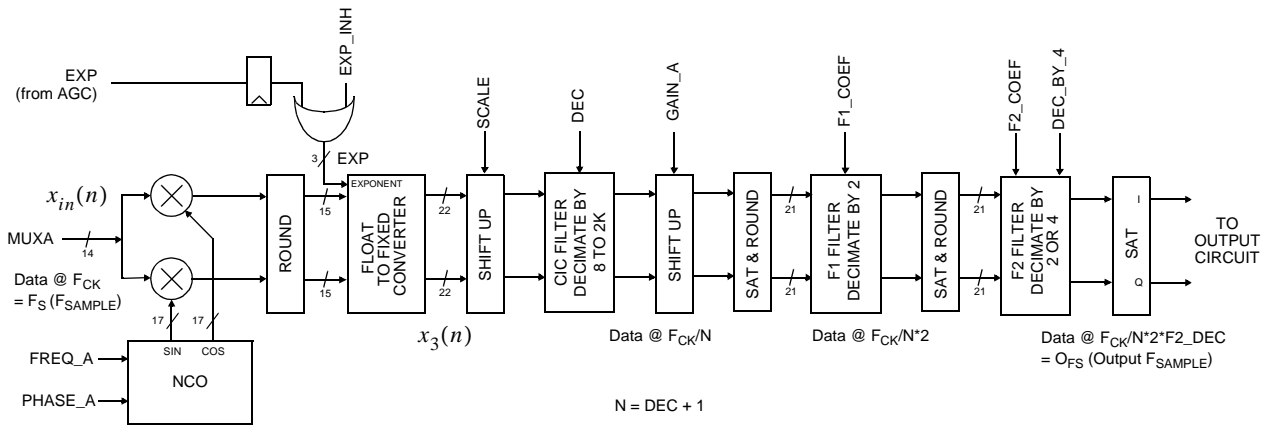

Figure 15 CLC5902 Down Converter, Channel A (Channel B is identical)

The “FLOAT TO FIXED CONVERTER” circuit expands the dynamic range compression performed by the DVGA. Signals from this point onward extend across the full dynamic range of the signals applied to the DVGA input. This allows the AGC to operate continuously through a burst without producing artifacts in the signal due to the settling response of the decimation filters after a 6dB DVGA gain adjustment. For example, if the DVGA input signal were to increase causing the ADC output level to cross the AGC threshold level, the gain of the DVGA would change by -6dB. The 6dB step is allowed to propagate through the ADC and mixers and is compensated out just before the filtering. The accuracy of the compensation is dependent on the accuracy of the DVGA gain step. This operating mode requires 21 bits (14-bit ADC output + 7-bit shift) to represent the full linear dynamic range of the signal. The output word must be set to either 24-bit or 32-bit to take advantage of the entire dynamic range available. The CLC5902 can also be configured to output a floating point format with up to 138dB of numerical resolution using only 12 output bits.

The “SHIFT UP” circuit will be discussed in the Four Stage CIC filter section on page 14.

A 4-stage cascaded-integrator-comb (CIC) filter and a two-stage decimate by 4 or 8 finite impulse response (FIR) filter are used to lowpass filter and isolate the desired signal. The CIC filter reduces the sample rate by a programmable factor ranging from 8 to 2048 (decimation ratio). The CIC outputs are followed by a gain stage and then followed by a two-stage decimate by 4 or 8 filter. The gain circuit allows the user to boost the gain of weak signals by up to 42 dB in 6 dB steps. It also rounds the signal to 21 bits and saturates at plus or minus full scale.

The first stage of the two stage filter is a 21-tap, symmetric decimate by 2 FIR filter (F1) with programmable 16 bit tap weights. The coefficients of the first 11 taps are downloaded to the chip as 16 bit words. Since the filter is a symmetric configuration only the first 11 coefficients must be loaded. The F1 section on page 15 provides a generic set of coefficients that compensate for the rolloff of the CIC filter and provide a passband flat to 0.01dB with 70 dB of out of band rejection. A second coefficient set is provided that has a narrower output passband and greater out-of-band rejection. The second set of coefficients is ideal for systems such as GSM where far-image rejection is more important than adjacent channel rejection.

The second stage is a 63 tap decimate by 2 or 4 programmable FIR filter (F2) also with 16 bit tap weights. Filter coefficients for a flat response from $-0.4F_S$ to $+0.4F_S$ of the output sample rate with 80dB of out of band rejection are provided in the F2 section. A second set of F2 coefficients is also provided to enhance performance for GSM systems. The user can also design and download their own final filter to customize the channel’s spectral response. Typical uses of programmable filter F2 include matched (root-raised cosine) filtering, or filtering to generate over-sampled outputs with greater out of band rejection. The 63 tap symmetrical filter is downloaded into the chip as 32 words, 16 bits each. Saturation to plus or minus full scale is performed at the output of F1 and F2 to clip the signal rather than allow it to roll over.

The Numerically Controlled Oscillator

The tuning frequency of each down converter is specified as a 32 bit word (.02Hz resolution at $CK=52MHz$) and the phase offset is specified as a 16 bit word (.005°). These two parameters are applied to the Numerically Controlled

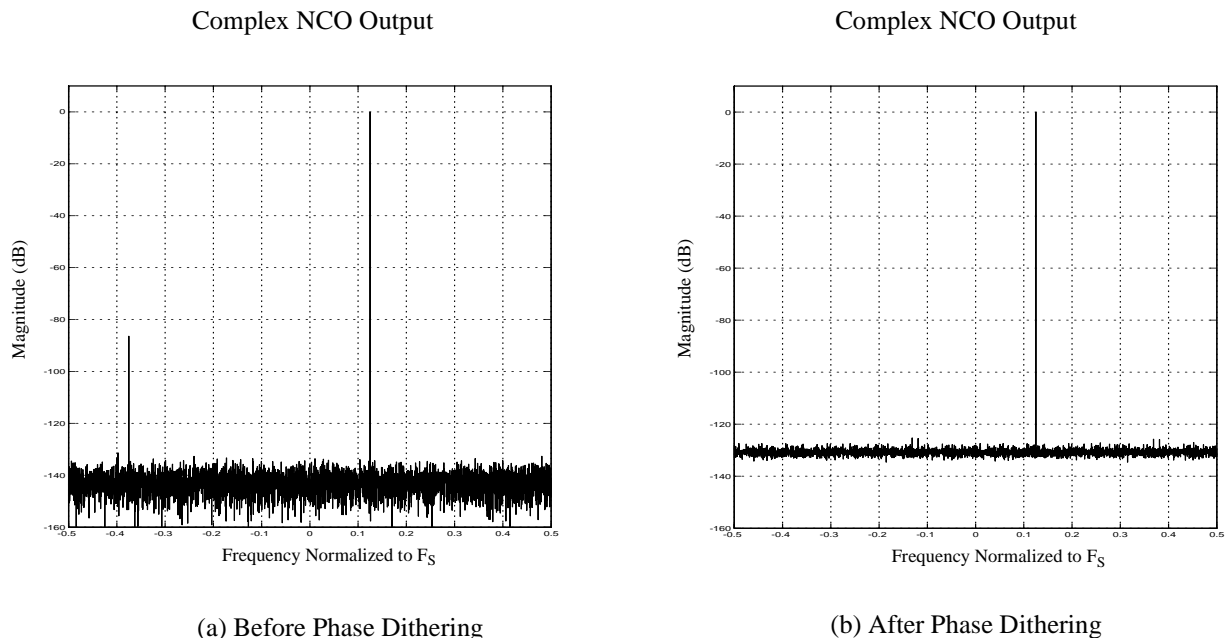

Figure 16 Example of NCO spurs due to phase truncation

Oscillator (NCO) circuit to generate sine and cosine signals used by the digital mixer. The NCOs can be synchronized with NCOs on other chips via the sync pin **SI**. This allows multiple down converter outputs to be coherently combined, each with a unique phase and amplitude.

The tuning frequency is set by loading the **FREQ** register according to the formula $FREQ = 2^{32}F/F_{CK}$, where F is the desired tuning frequency and F_{CK} is the chip's clock rate. **FREQ** is a 2's complement word. The range for F is from $-F_{CK}/2$ to $+F_{CK}(1-2^{-31})/2$.

In some cases the sampling process causes the order of the I and Q components to be reversed. Should this occur simply invert the polarity of the tuning frequency F .

The 2's complement format represents full-scale negative as 10000000 and full-scale positive as 01111111 for an 8-bit example.

The 16 bit phase offset is set by loading the **PHASE** register according to the formula $PHASE = 2^{16}P/2\pi$, where P is the desired phase in radians ranging between 0 and 2π . **PHASE** is an unsigned 16-bit number. P ranges from 0 to $2\pi(1-2^{-16})$.

Phase dithering can be enabled to reduce the spurious signals created by the NCO due to phase truncation. This truncation is unavoidable since the frequency resolution is much finer than the phase resolution. With dither enabled, spurs due to phase truncation are below -100 dBc for all frequencies and phase offsets. Each NCO has its own dither source and the initial state of one is maximally offset with respect to the other so that they are effectively uncorrelated. The phase dither sources are on by default. They are independently controlled by the **DITH_A** and **DITH_B** bits. The amplitude resolution of the ROM creates a worst-case spur amplitude of -101dBc rendering amplitude dither unnecessary.

The spectrum plots in Figure 16 show the effectiveness of phase dither in reducing NCO spurs due to phase truncation for a worst-case example (just below $F_S/8$). With dither off, the spur is at -86.4dBFS. With dither on, the spur is below -125dBFS, disappearing into the noise floor. This spur is spread into the noise floor which results in an SNR of -83.6dBFS.

Figure 17 shows the spur levels as the tuning frequency is scanned over a narrow portion of the frequency range. The spurs are again a result of phase quantization but their locations move about as the frequency scan progresses. As before, the peak spur level drops when dithering is enabled. When dither is enabled and the fundamental frequency is exactly at $F_S/8$, the worst-case spur due to amplitude quantization can be observed at -101dBc in Figure 18.

Complex NCO Output
Phase Dither Disabled

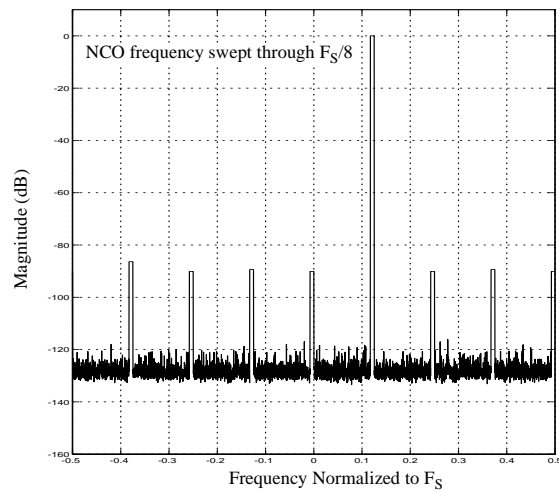

Figure 17 NCO Spurs due to Phase Quantization

Complex NCO Output
Phase Dither Enabled

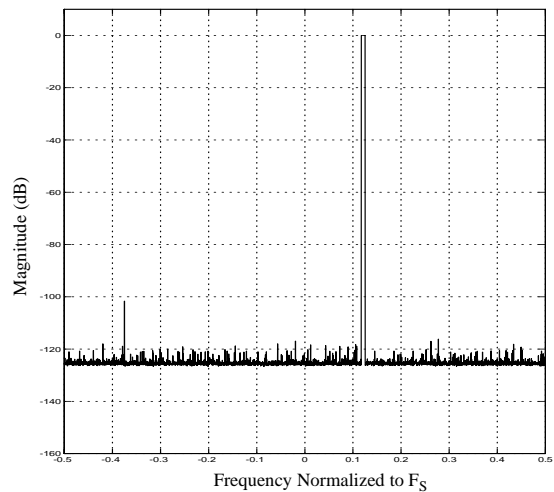

Figure 18 Worst Case Amplitude Spur, NCO at $F_S/8$

Four Stage CIC Filter

The mixer outputs are decimated by a factor of N in a four stage CIC filter. N is programmable to any integer between 8 and 2048. Decimation is programmed in the **DEC** register where $DEC = N - 1$. The programmable decimation allows the chip's usable output bandwidth to range from about 2.6kHz to 1.3MHz when the input data rate (which is equal to the chip's clock rate, F_{CK}) is 52 MHz. A block diagram of the CIC filter is shown in Figure 19.

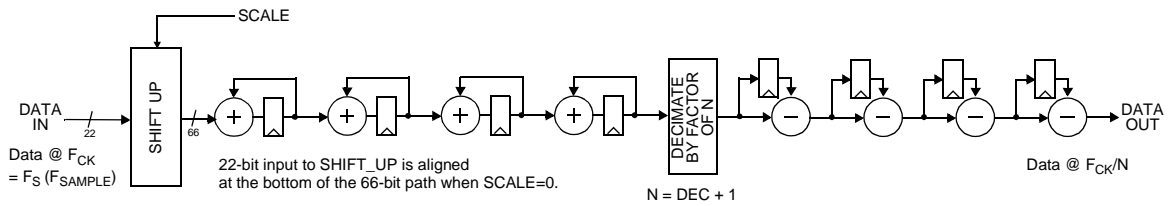

Figure 19 Four-stage decimate by N CIC filter

The CIC filter has a gain equal to N^4 (filter decimation⁴) which must be compensated for in the “SHIFT UP” circuit shown in Figure 19 as well as Figure 15. This circuit has a gain equal to $2^{(SCALE-44)}$, where SCALE ranges from 0 to 40. This circuit divides the input signal by 2^{44} providing maximum headroom through the CIC filter. For optimal noise performance the SCALE value is set to increase this level until the CIC filter is just below the point of distortion. A value is normally calculated and loaded for SCALE such that $GAIN_{SHIFTUP} \cdot GAIN_{CIC} \leq 1$. The actual gain of the CIC filter will only be unity for power-of-two decimation values. In other cases the gain will be somewhat less than unity.

Channel Gain

The gain of each channel can be boosted up to 42 dB by shifting the output of the CIC filter up by 0 to 7 bits prior to rounding it to 21 bits. For channel A, the gain of this stage is: $GAIN = 2^{GAIN_A}$, where GAIN_A ranges from 0 to 7. Overflow due to the GAIN circuit is saturated (clipped) at plus or minus full scale. Each channel can be given its own GAIN setting.

First Programmable FIR Filter (F1)

The CIC/GAIN outputs are followed by two stages of filtering. The first stage is a 21 tap decimate-by-2 symmetric FIR filter with programmable coefficients. Typically, this filter compensates for a slight droop induced by the CIC filter. In addition, it often provides stopband assistance to F2 when deep stop bands are required. The filter coefficients are 16-bit 2’s complement numbers. Unity gain will be achieved through the filter if the sum of the 21 coefficients is equal to 2^{16} . If the sum is not 2^{16} , then F1 will introduce a gain equal to $(\text{sum of coefficients})/2^{16}$. The 21 coefficients are identified as coefficients $h_1(n)$, $n = 0, \dots, 20$ where $h_1(10)$ is the center tap. The coefficients are symmetric, so only the first 11 are loaded into the chip.

Two example sets of coefficients are provided here. The first set of coefficients, referred to as the standard set (STD), compensates for the droop of the CIC filter providing a passband which is flat (0.01 dB ripple) over 95% of the final output bandwidth with 70dB of out-of-band rejection (see Figure 20). The filter has a gain of 0.999 and is

symmetric with the following 11 unique taps (1|21, 2|20, ..., 10|12, 11):

29, -85, -308, -56, 1068, 1405, -2056, -6009,
1303, 21121, 32703

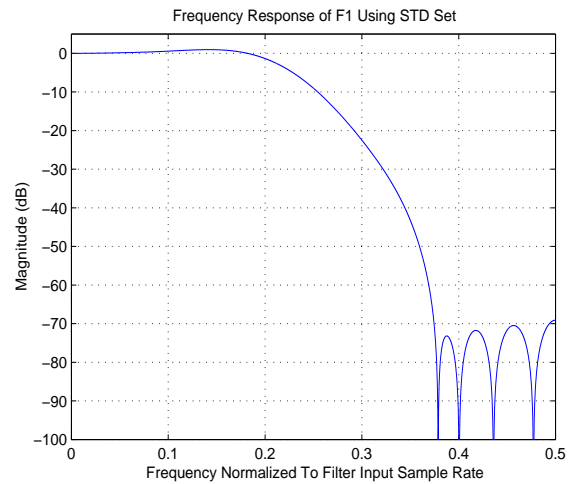

Figure 20 F1 STD frequency response

The second set of coefficients (GSM set) are intended for applications that need deeper stop bands or need oversampled outputs. These requirements are common in cellular systems where out of band rejection requirements can exceed 100dB (see Figure 21). They are useful for wide-band radio architectures where the channelization is done after the ADC. These filter coefficients introduce a gain of 0.984 and are:

-49, -340, -1008, -1617, -1269, 425, 3027, 6030,
9115, 11620, 12606

Second Programmable FIR Filter (F2)

The second stage decimate by two or four filter also uses externally downloaded filter coefficients. The filter coefficients are 16-bit 2’s complement numbers. Unity gain will be achieved through the filter if the sum of the 63 coefficients is equal to 2^{16} . If the sum is not 2^{16} , then the F2 will introduce a gain equal to $(\text{sum of coefficients})/2^{16}$.

The 63 coefficients are identified as $h_2(n)$, $n = 0, \dots, 62$ where $h_2(31)$ is the center tap. The coefficients are symmetric, so only the first 32 are loaded into the chip.

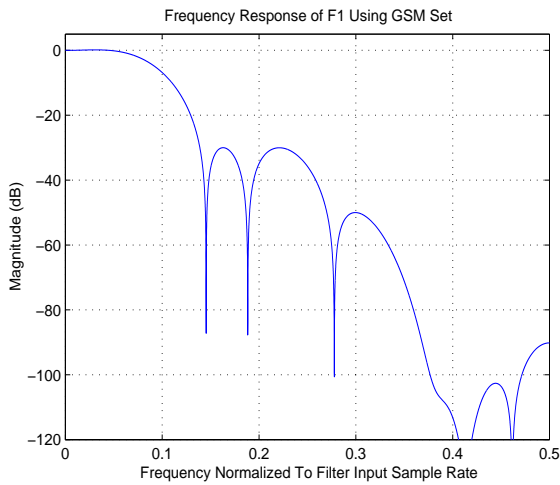

Figure 21 F1 GSM frequency response

An example filter (STD F2 coefficients, see Figure 22) with 80dB out-of-band rejection, gain of 1.00, and 0.03 dB peak to peak passband ripple is created by this set of 32 unique coefficients:

-14, -20, 19, 73, 43, -70, -82, 84, 171, -49, -269, -34, 374, 192, -449,
 -430, 460, 751, -357, -1144, 81, 1581, 443, -2026,
 -1337, 2437, 2886,
 -2770, -6127, 2987, 20544, 29647

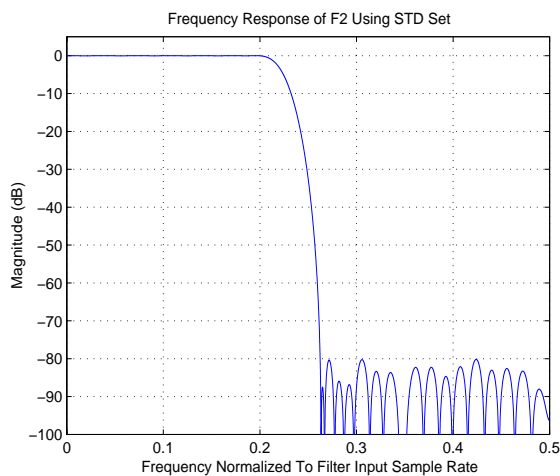

Figure 22 F2 STD frequency response

A second set of F2 coefficients (GSM set, see Figure 23) suitable for meeting the stringent wideband GSM requirements with a gain of 0.999 are:

-536, -986, 42, 962, 869, 225, 141, 93, -280, -708,
 -774, -579, -384,
 -79, 536, 1056, 1152, 1067, 789, 32, -935, -1668,
 -2104, -2137, -1444,
 71, 2130, 4450, 6884, 9053, 10413, 10832

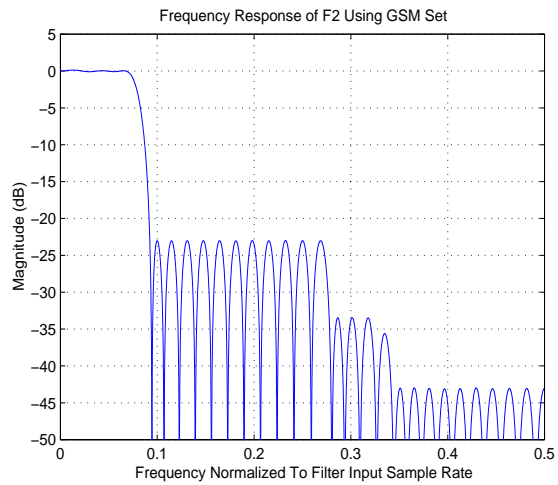

Figure 23 F2 GSM frequency response

The filter coefficients of both filters can be used to tailor the spectral response to the user's needs. For example, the first can be loaded with the standard set to provide a flat response through to the second filter. The latter can then be programmed as a Nyquist (typically a root-raised-cosine) filter for matched filtering of digital data.

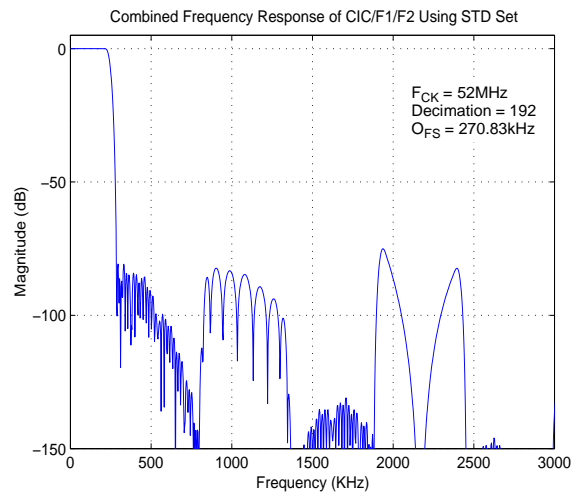

Figure 24 CIC, F1, & F2 STD frequency response

The complete channel filter response for standard coefficients is shown in Figure 24. Passband flatness is shown in Figure 25.

The complete filter response for GSM coefficients is shown in Figure 26.

GSM Passband flatness is shown in Figure 27.

The mask shown in Figure 26 is derived from the ETSI GSM 5.05 specifications for a normal Basestation Transceiver (BTS). For interferers, 9dB was added to the carrier to interference (C/I) ratios. For blockers, 9dB was added to the difference between the blocker level and 3dB above the reference sensitivity level.

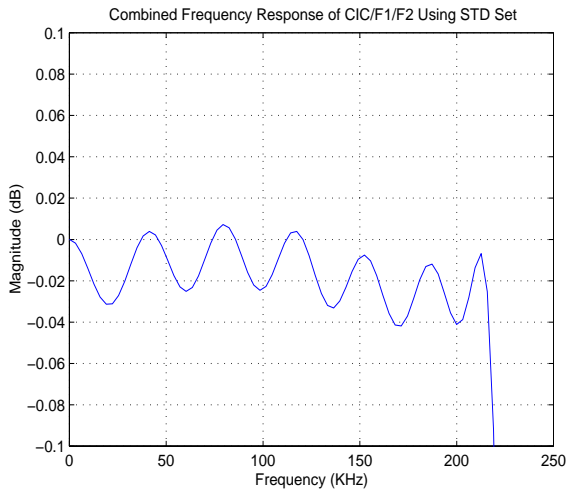

Figure 25 CIC, F1, & F2 STD Passband Flatness

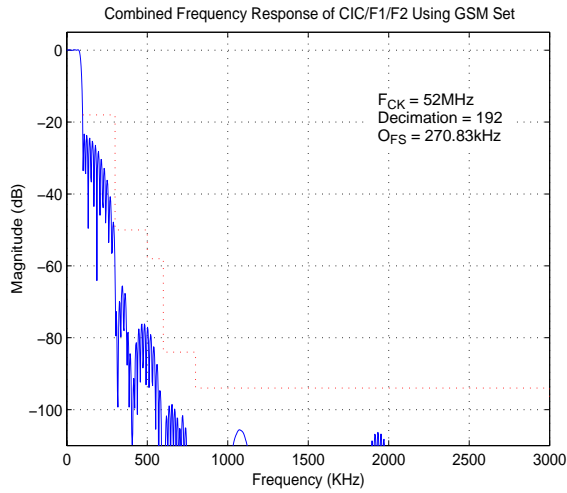

Figure 26 CIC, F1, & F2 GSM frequency response

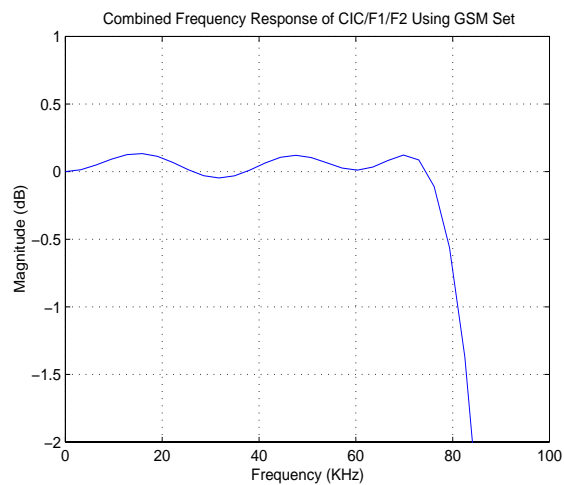

Figure 27 CIC, F1, & F2 GSM Passband Flatness

Overall Channel Gain

The overall gain of the chip is a function of the amount of decimation (N), the settings of the “SHIFT UP” circuit (SCALE), the GAIN setting, the sum of the F1 coefficients, and the sum of the F2 coefficients. The overall gain is shown below in Equation 2.

$$G_{DDC} = \frac{1}{2}(DEC + 1)^4 \quad \text{EQ. 2}$$

$$\cdot 2^{[SCALE - 44 - AGAIN \cdot (1 - EXP_INH)]}$$

$$\cdot 2^{GAIN}$$

$$\cdot G_{F1} \cdot G_{F2}$$

Where:

$$G_{F1} = \frac{\sum_{i=1}^{21} h_1(i)}{2^{16}} \quad \text{EQ. 3}$$

and:

$$G_{F2} = \frac{\sum_{i=1}^{63} h_2(i)}{2^{16}} \quad \text{EQ. 4}$$

It is assumed that the DDC output words are treated as fractional 2's complement words. The numerators of G_{F1} and G_{F2} equal the sums of the impulse response coefficients of F1 and F2, respectively. For the STD and GSM sets, G_{F1} and G_{F2} are nearly equal to unity. Observe that the *AGAIN* term in EQ. 2 is cancelled by the DVGA operation so that the entire gain of the DRCS is independent of the DVGA setting when *EXP_INH*=0. The $\frac{1}{2}$ appearing in EQ. 2 is the result of the 6dB conversion loss in the mixer. For full-scale square wave inputs the $\frac{1}{2}$ should be set to 1 to prevent signal distortion.

Data Latency and Group Delay

The latency from a sync event to data output is approximately 8N **CK** periods for F2 decimation by 2 and 24N **CK** periods for F2 decimation by 4. Actual non-zero data output can be further delayed depending on the F1 and F2 filter coefficients.

Group Delay is approximately 90N **CK** periods for F2 decimation by 2 or 4.

Output Modes

After processing by the DDC, the data is then formatted for output.

Note

All output data is two's complement.

Output formats include truncation to 8 or 32 bits, rounding to 16 or 24 bits, and a 12-bit floating point format (4-bit exponent, 8-bit mantissa, 138dB numeric range). This function is performed in the OUTPUT CIRCUIT shown in Figure 28.

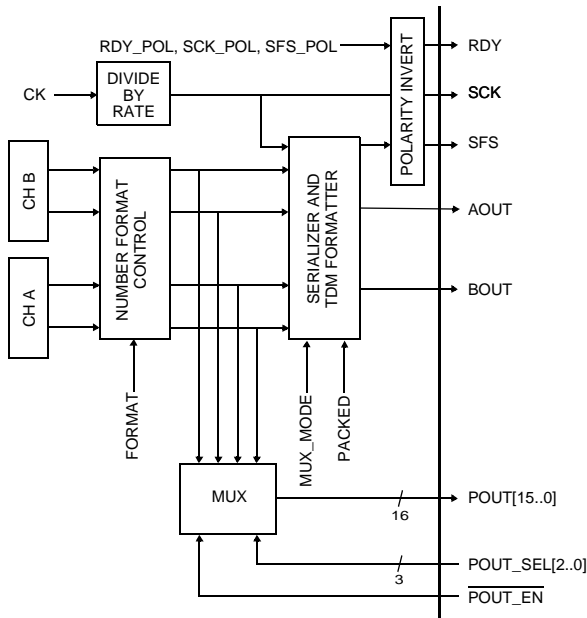

Figure 28 CLC5902 output circuit

The channel outputs are accessible through serial output pins and a 16-bit parallel output port. The **RDY** pin is provided to notify the user that a new output sample period (OSP) has begun. OSP refers to the interval between output samples at the decimated output rate. For example, if the input rate (and clock rate) is 52 MHz and the overall decimation factor is 192 ($N=48$, $F2$ decimation=2) the OSP will be 3.69 microseconds which corresponds to an output sample rate of 270.83kHz. An OSP starts when a sample is ready and stops when the next one is ready.

Note

The serial outputs power up in a tri-state condition and must be enabled when the chip is configured. Parallel outputs are enabled by the POUT_EN pin.

Serial Outputs

The CLC5902 provides a serial clock (**SCK**), a frame strobe (**SFS**) and two data lines (**AOUT** and **BOUT**) to output serial data. The MUX_MODE control register specifies whether the two channel outputs are transmitted on two separate serial pins, or multiplexed onto one pin in a time division multiplexed (TDM) format. Separate output pins are not provided for the I and Q halves of complex data. The I and Q outputs are always multiplexed onto the same serial pin. The I-component is output first, followed by the Q-component. By setting the PACKED mode bit to '1' a complex pair may be treated as a single double-wide word. The **RDY** signal is used to identify the first word of a complex pair of the TDM formatted output. The TDM modes are summarized in Table 2.

MUX_MODE	SERIAL OUTPUTS	
	AOUT	BOUT
0	OUT _A	OUT _B
1	OUT _A , OUT _B	LOW

Table 2 TDM Modes

The serial outputs use the format shown in Figure 29. Figure 29(a) shows the standard output mode (the PACKED mode bit is low). The chip clocks the frame and data out of the chip on the rising edge of **SCK** (or falling edge if the SCK_POL bit in the input control register is set high). Data should be captured on the falling edge of **SCK** (rising if SCK_POL=1). The chip sends the I data first by setting **SFS** high (or low if SFS_POL in the input control register is set high) for one clock cycle, and then transmitting the data, MSB first, on as many **SCK** cycles as are necessary. Without a pause, the Q data is transferred next as shown in Figure 29(a). If the PACKED control bit is high, then the I and Q components are sent as a double length word with only one **SFS** strobe as shown in Figure 29(b). If both channels are multiplexed out the same serial pin, then the subsequent I/Q channel words will be transmitted immediately following the first I/Q pair as shown in Figure 29(c). Figure 29(c) also shows how the **RDY** signal can be used to identify the I and Q channels in the TDM serial transmission. The serial output rate is programmable using the RATE register as a integer division of the input clock, the division ratio ranging from 1 to 256. The serial interface will not work properly if the programmed rate of **SCK** is insufficient to clock out all the bits in one OSP.

Serial Port Output Number Formats

Several numeric formats are selectable using the FORMAT control register. The I/Q samples can be rounded to 16 or 24 bits, or truncated to 8 bits. The packed mode works as described above for these fixed point formats. A floating point format with 138dB of dynamic range in 12 bits is also provided. The mantissa (m) is 8 bits and the exponent (e) is 4 bits. The MSB of each segment is trans-

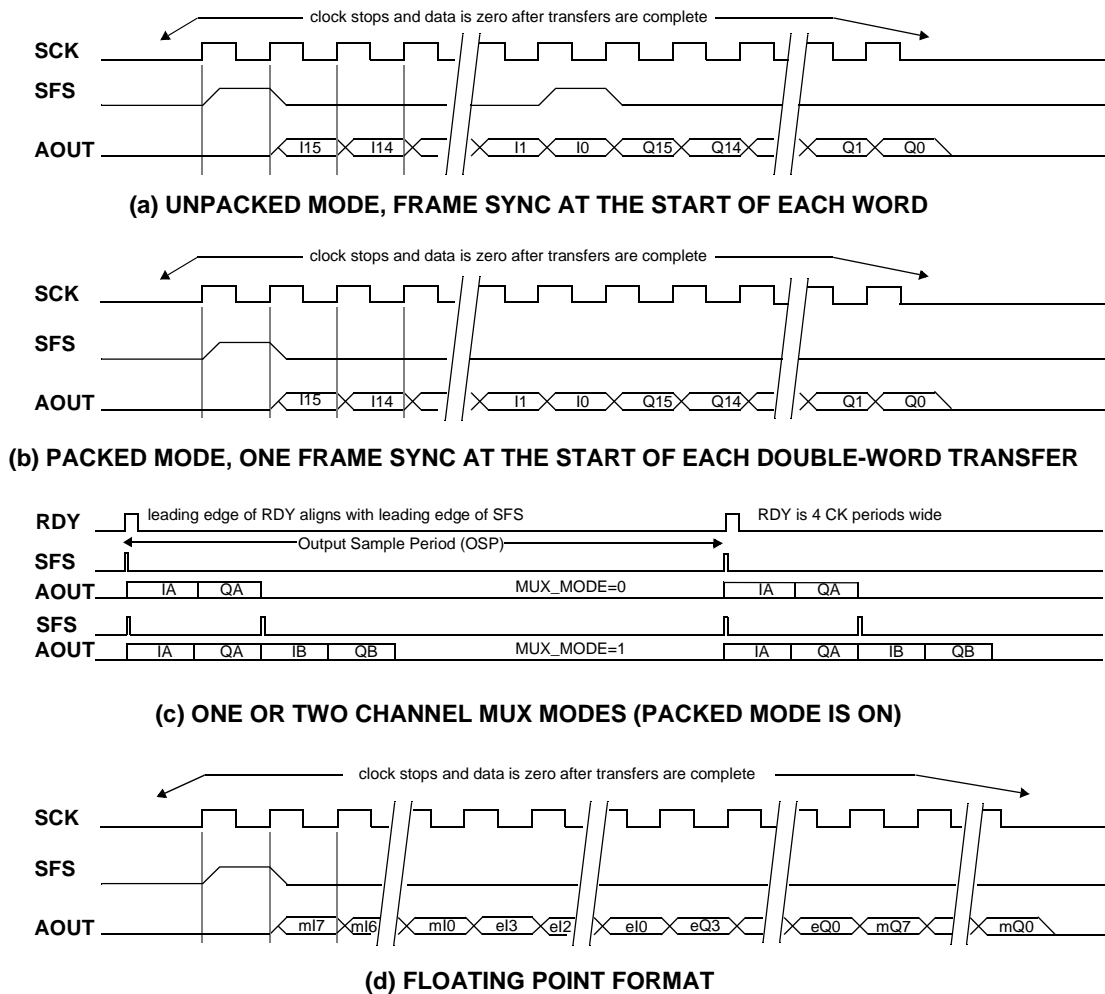

Figure 29 Serial output formats. Refer to Figure 9 for detailed timing information

mitted first. When this mode is selected, the I/Q samples are packed regardless of the state of MUX_MODE, and the data is sent as mI/eI/eQ/mQ which allows the two exponents to form an 8-bit word. This is shown in Figure 29(d). For all formats, once the defined length of the word is complete, SCK stops toggling.

Parallel Outputs

Output data from the channels can also be taken from a 16-bit parallel port. A 3-bit word applied to the POUT_SEL[2:0] pins determines which 16-bit segment is multiplexed to the parallel port. Table 3 defines this mapping. To allow for bussing of multiple chips, the parallel port is tri-stated unless POUT_EN is low. The RDY signal indicates the start of an OSP and that new data is ready at the parallel output. The user has one OSP to cycle through whichever registers are needed. The RATE register must be set so that each OSP is at least 5 SCK periods.

Parallel Port Output Numeric Formats

The I/Q samples can be rounded to 16 or 24 bits or the full 32 bit word can be read. By setting the word size to 32 bits it is possible to read out the top 16 bits and only observe the top 8 bits if desired. Additionally, the output samples

can be formatted as floating point numbers with an 8-bit mantissa and a 4 bit exponent. For the fixed-point formats, the valid bits are justified into the MSBs of the registers of Table 3 and all other bits are set to zero. For the floating

POUT_SEL	Normal Register Contents	Floating Point Register Contents
0	IA upper 16 bits	0000/eIA/mIA
1	IA lower 16 bits	0x0000
2	QA upper 16 bits	0000/eQA/mQA
3	QA lower 16 bits	0x0000
4	IB upper 16 bits	0000/eIB/mIB
5	IB lower 16 bits	0x0000
6	QB upper 16 bits	0000/eQB/mQB
7	QB lower 16 bits	0x0000

Table 3 Register Selection for Parallel Output

point format, the valid bits are placed in the upper 16 bits of the appropriate channel register using the format 0000/eI/mI for the I samples.

AGC

The CLC5902 AGC processor monitors the output level of the ADC and servos it to the desired setpoint. The ADC input is controlled by the DVGA to maintain the proper setpoint level. DVGA operation results in a compression of the signal through the ADC. The DVGA signal compression is reversed in the CLC5902 to provide > 120dB of linear dynamic range. This is illustrated in Figure 30.

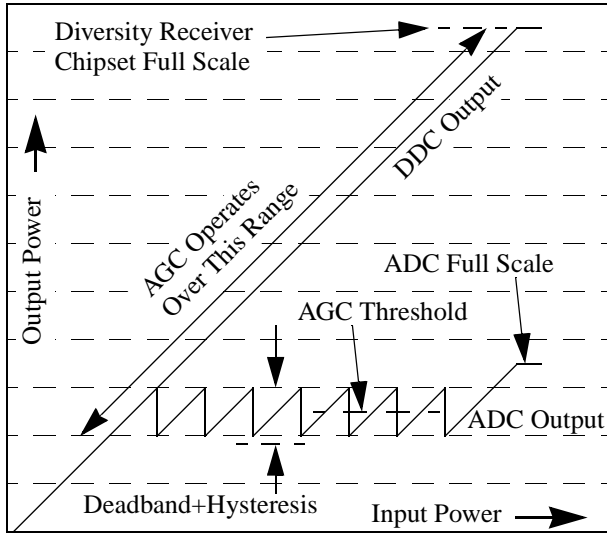

Figure 30 Output Gain Scaling vs. Input Signal

In order to use the AGC the DRCS Control Panel software should be used to calculate the programmable parameters. To generate these parameters only the desired setpoint, deadband+hysteresis, and loop time constant need to be supplied. All subsequent calculations are performed by the software. Complete details of the AGC operation are provided in an appendix but are not required reading.

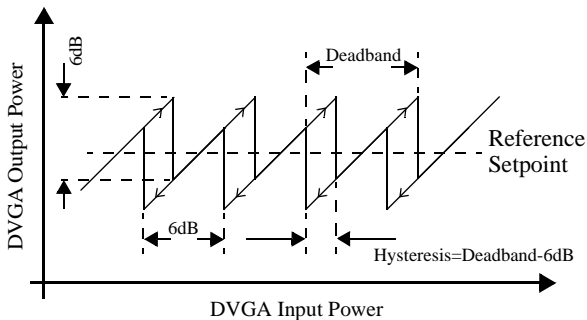

Figure 31 AGC Setup.

AGC setpoint and deadband+hysteresis are illustrated in Figure 31. The loop time constant is a measure of how fast the loop will track a changing signal. Values down to approximately 1.0 microsecond will be stable with the second order LC noise filter. Since the DVGA operates with

6dB steps the deadband should always be greater than 6dB to prevent oscillation. An increased deadband value will reduce the amount of AGC operation. A decreased deadband value will increase the amount of AGC operation but will hold the ADC output closer to the setpoint. The threshold should be set so that transients do not cause sustained overrange at the ADC inputs. The threshold setting can also be used to set the ADC input near its optimal performance level.

The AGC may be configured to free run, operate for a programmable period of time (burst mode), or stop running. If a burst start pulse is applied to the **AGC_EN** pin in burst mode, the AGC will free run for **AGC_HOLD_COUNT CK** periods then freeze. At the beginning of the next burst either the freeze value is maintained or an initial condition is set from **AGC_IC_A|B** based on **AGC_RESET_EN**. Allowing the AGC to free run should be appropriate for most applications. Table 4 shows the AGC mode control bits.

AGC Mode	AgcHldIC	AgcRstEn	AgcForce
Free Run	0	0	1
Burst, hold previous value	0	0	0
Burst, use initial conditions	0	1	0
Manual	1	0	0

Table 4 AGC Operating Modes

Power Management

The CLC5902 can be placed in a low power (static) state by stopping the input clock. To prevent this from placing the CLC5902 into unexpected states, the **SI** pin of the CLC5902 should be asserted prior to disabling the input clock and held asserted until the input clock has returned to a stable condition.

Test and Diagnostics

The CLC5902 supports IEEE 1149.1 compliant JTAG Boundary Scan for the I/O's. The following pins are used:

$\overline{\text{TRST}}$	(test reset)
TMS	(test mode select)
TDI	(test data in)
TDO	(test data out)
TCK	(test clock)

The following JTAG instructions are supported:

<u>Instruction</u>	<u>Description</u>
BYPASS	Connects TDI directly to TDO
EXTEST	Drives the 'extest' TAP controller output
IDCODE	Connects the 32-bit ID register to TDO
SAMPLE/PRELOAD	Drives the 'samp_load' TAP controller output
HIGHZ	Tri-states the outputs

The JTAG Boundary Scan can be used to verify printed circuit board continuity at the system level.

The user is able to program a value into TEST_REG and substitute this for the normal channel inputs from the **AIN/BIN** pins by selecting it with the crossbar. With the NCO frequency set to zero this allows the DDCs and the output interface of the chip to be verified. Also, the AGC loop can be opened by setting AGC_HOLD_IC high and setting the gain of the DVGA by programming the appropriate value into the AGC_IC_A/B register.

Real-time access to the following signals is provided by configuring the control interface debug register:

- NCO sine and cosine outputs
- data after round following mixers
- data before F1 and F2
- data after the CIC filter within the AGC

The access points are multiplexed to a 20-bit parallel output port which is created from signal pins **POUT[15:0]**, **AOUT**, **BOUT**, **SFS**, and **RDY** according to the table below:

<u>Normal Mode Pin</u>	<u>Debug Mode Pin</u>
POUT[15:0]	DEBUG[19..4]
RDY	DEBUG[3]
SFS	DEBUG[2]
AOUT	DEBUG[1]
BOUT	DEBUG[0]

SCK will be set to the proper strobe rate for each debug tap point. $\overline{\text{POUT_EN}}$ and **PSEL[2..0]** have no effect in Debug Mode. The outputs are turned on when the Debug Mode bit is set. Normal serial outputs are also disabled.

Control Registers

The chip is configured and controlled through the use of 8-bit control registers. These registers are accessed for reading or writing using the control bus pins ($\overline{\text{CE}}$, $\overline{\text{RD}}$, $\overline{\text{WR}}$, A[7:0], and D[7:0]) described in the Control Interface section. The register names and descriptions are listed in Table 5.

Control Registers

Register Name	Width	Type	Default ^a	Addr	Bit	Description
DEC	11b	R/W	7	0(LSBs) 1(MSBs)	7:0 2:0	CIC decimation control. N=DEC+1. Valid range is from 7 to 2047. Format is an unsigned integer. This affects both channels.
DEC_BY_4	1b	R/W	0	1	4	Controls the decimation factor in F2. 0=Decimate by 2. 1=Decimate by 4. This affects both channels.
SCALE	6b	R/W	0	2	5:0	CIC SCALE parameter. Format is an unsigned integer representing the number of left bit shifts to perform on the data prior to the CIC filter. Valid range is from 0 to 40. This affects both channels.
GAIN_A	3b	R/W	0	3	2:0	Value of left bit shift prior to F1 for channel A.
GAIN_B	3b	R/W	0	4	2:0	Value of left bit shift prior to F1 for channel B.
RATE	1B	R/W	1	5	7:0	Determines rate of serial output clock. The output rate is FCK/(RATE+1). Unsigned integer.
SOUT_EN	1b	R/W	0	6	0	Enables the serial output pins AOUT , BOUT , SCK , and SFS . 0=Tristate. 1=Enabled.
SCK_POL	1b	R/W	0	6	1	Determines polarity of the SCK output. 0= AOUT , BOUT , and SFS change on the rising edge of SCK (capture on falling edge). 1=They change on the falling edge of SCK.
SFS_POL	1b	R/W	0	6	2	Determines polarity of the SFS output. 0=Active High. 1=Active Low.
RDY_POL	1b	R/W	0	6	3	Determines polarity of the RDY output. 0=Active High. 1=Active Low.
MUX_MODE	1b	R/W	0	6	4	Determines the mode of the serial outputs. 0=Each channel is output on its respective pin, 1=Both channels are multiplexed and output on AOUT . See also Table 2.
PACKED	1b	R/W	0	6	5	Controls when SFS goes active. 0= SFS pulses prior to the start of the I and the Q words. 1= SFS pulses only once prior to the start of each I/Q sample pair (i.e. the pair is treated as a double-sized word) The I word precedes the Q word. See Figure 29.
FORMAT	2b	R/W	0	6	6:7	Determines output number format. 0=Truncate serial output to 8 bits. Parallel output is truncated to 32 bits. 1=Round both serial and parallel to 16 bits. All other bits are set to 0. 2=Round both serial and parallel to 24 bits. All other bits are set to 0. 3=Output floating point. 8-bit mantissa, 4-bit exponent. All other bits are set to 0.

Table 5 CLC5902 Control Registers

Register Name	Width	Type	Default ^a	Addr	Bit	Description
FREQ_A	4B	R/W	0	7-10	7:0	Frequency word for channel A. Format is a 32-bit, 2's complement number spread across 4 registers. The LSBs are in the lower registers. The NCO frequency F is $F/F_{CK}=FREQ_A/2^{32}$.
PHASE_A	2B	R/W	0	11-12	7:0	Phase word for channel A. Format is a 16-bit, unsigned magnitude number spread across 2 registers. The LSBs are in the lower registers. The NCO phase PHI is $PHI=2\pi \cdot PHASE_A/2^{16}$.
FREQ_B	4B	R/W	0	13-16	7:0	Frequency word for channel B. Format is a 32-bit, 2's complement number spread across 4 registers. The LSBs are in the lower registers. The NCO frequency F is $F/F_{CK}=FREQ_B/2^{32}$.
PHASE_B	2B	R/W	0	17-18	7:0	Phase word for channel B. Format is a 16-bit, unsigned magnitude number spread across 2 registers. The LSBs are in the lower registers. The NCO phase PHI is $PHI=2\pi \cdot PHASE_B/2^{16}$.
A_SOURCE	2	R/W	0	19	1:0	0=Select AIN as channel input source. 1=Select BIN . 2=3=Select TEST_REG as channel input source.
B_SOURCE	2	R/W	1	19	2:3	0=Select AIN as channel input source. 1=Select BIN . 2=3=Select TEST_REG as channel input source.
EXP_INH	1b	R/W	0	20	0	0=Allow exponent to pass into FLOAT TO FIXED converter. 1=Force exponent in DDC channel to a 7 (maximum digital gain). This affects both channels.
AGC_FORCE	1b	R/W	1	20	1	0=Enable AGC counter operation. 1=AGC loop operates continuously regardless of AGC_EN pin. This affects both channels.
AGC_RESET_EN	1b	R/W	0	20	2	0=Initial condition is never used. 1=Integrator is reset each time the AGC transitions from idle to active. This affects both channels.
AGC_HOLD_IC	1b	R/W	0	20	3	0=Normal closed-loop operation. 1=Hold integrator at initial condition. This affects both channels.
AGC_LOOP_GAIN	2b	R/W	0	20	4:5	Bit shift value for AGC loop. Valid range is from 0 to 3. This affects both channels.
AGC_COUNT	2B	R/W	0	21-22	7:0	Counter value for AGC enable counter. Format is a 16-bit, unsigned magnitude number spread across 2 registers. The LSBs are in the lower register. The value represents the number of CK cycles over which the loop is active.
AGC_IC_A	1B	R/W	0	23	7:0	AGC integrator initial condition for channel A. Format is an 8-bit, unsigned magnitude number. This number is written into the magnitude MSBs of the channel A AGC integrator whenever it is reset to the initial condition.
AGC_IC_B	1B	R/W	0	24	7:0	AGC integrator initial condition for channel B. Format is an 8-bit, unsigned magnitude number. This number is written into the magnitude MSBs of the channel B AGC integrator whenever it is reset to the initial condition.
AGC_RB_A	1B	R	0	25	7:0	AGC integrator readback value for channel A. Format is an 8-bit, unsigned magnitude number. The user can read the magnitude MSBs of the channel A integrator from this register.
AGC_RB_B	1B	R	0	26	7:0	AGC integrator readback value for channel B. Format is an 8-bit, unsigned magnitude number. The user can read the magnitude MSBs of the channel B integrator from this register.
TEST_REG	14b	R/W	0	27(LSBs) 28(MSBs)	7:0 5:0	Test input source. Instead of processing values from the AIN/BIN pins, the value from this location is used instead. Format is 14-bit 2s complement number spread across 2 registers.
Reserved	1B	-	-	29	7:0	For future use.
Reserved	1B	-	-	30	7:0	For future use.
DEBUG_EN	1b	R/W	0	31	0	0=Normal. 1=Enables access to the internal probe points.
DEBUG_TAP	5b	R/W	0	31	1:5	Selects internal node tap for debug. 0 selects F1 output for BI, 20 bits 1 selects F1 output for BQ, 20 bits 2 selects F1 output for AQ, 20 bits 3 selects F1 output for AI, 20 bits 4 selects F1 input for BI, 20 bits 5 selects F1 input for BQ, 20 bits 6 selects F1 input for AI, 20 bits 7 selects F1 input for AQ, 20 bits 8 selects NCO A, cosine output, 17 bits, 3 LSBs are 0. 9 selects NCO A, sine output, 17 bits, 3 LSBs are 0. 10 selects NCO B, cosine output, 17 bits, 3 LSBs are 0. 11 selects NCO B, sine output, 17 bits, 3 LSBs are 0. 12 selects NCO AI, rounded output, 15 bits, 5 LSBs are 0. 13 selects NCO AQ, rounded output, 15 bits, 5 LSBs are 0. 14 selects NCO BI, rounded output, 15 bits, 5 LSBs are 0. 15 selects NCO BQ, rounded output, 15 bits, 5 LSBs are 0. 16-31 selects AGC CIC filter output. 9 MSBs from ch A, next 9 bits from ch B, 2 LSBs are 0.
DITH_A	1b	R/W	1	31	6	0=Disable NCO dither source for channel A. 1=Enable.
DITH_B	1b	R/W	1	31	7	0=Disable NCO dither source for channel B. 1=Enable.
AGC_TABLE	32B	R/W	0	128-159	7:0	RAM space that defines key AGC loop parameters. Format is 32 separate 8-bit, 2's complement numbers. This is common to both channels.
F1_COEFF	22B	R/W	0	160-181	7:0	Coefficients for F1. Format is 11 separate 16-bit, 2's complement numbers, each one spread across 2 registers. The LSBs are in the lower registers. For example, coefficient h0[7:0] is in address 160, h0[15:8] is in address 161, h1[7:0] is in address 162, h1[15:8] is in address 163.
F2_COEFF	64B	R/W	0	182-245	7:0	Coefficients for F2. Format is 32 separate 16-bit, 2's complement numbers, each one spread across 2 registers. The LSBs are in the lower registers. For example, coefficient h0[7:0] is in address 182, h0[15:8] is in address 183, h1[7:0] is in address 184, h1[15:8] is in address 185.

Table 5 CLC5902 Control Registers

a. These are the default values set by a master reset (\overline{MR}). Sync in (\overline{SI}) will not affect any of these values.

Condensed Hexadecimal Address Map

Reg Name	Addr	Bit7	Bit6	Bit5	Bit4	Bit3	Bit2	Bit1	Bit0	
DEC	0x00	Dec7	Dec6	Dec5	Dec4	Dec3	Dec2	Dec1	Dec0	
DEC_BY_4	0x01				DecBy4		Dec10	Dec9	Dec8	
SCALE	0x02			Scale5	Scale4	Scale3	Scale2	Scale1	Scale0	
GAIN1_A	0x03						G1A2	G1A1	G1A0	
GAIN1_B	0x04						G1B2	G1B1	G1B0	
RATE	0x05	Rate7	Rate6	Rate5	Rate4	Rate3	Rate2	Rate1	Rate0	
SERIAL_CTRL	0x06	FMT1	FMT0	Packed	MuxMode	RDY_POL	SFS_POL	SCK_POL	SOUT_EN	
FREQ_A	0x07	FA7	FA6	FA5	FA4	FA3	FA2	FA1	FA0	
	0x08	FA15	FA14	FA13	FA12	FA11	FA10	FA9	FA8	
	0x09	FA23	FA22	FA21	FA20	FA19	FA18	FA17	FA16	
	0x0A	FA31	FA30	FA29	FA28	FA27	FA26	FA25	FA24	
PHASE_A	0x0B	PA7	PA6	PA5	PA4	PA3	PA2	PA1	PA0	
	0x0C	PA15	PA14	PA13	PA12	PA11	PA10	PA9	PA8	
FREQ_B	0x0D	FB7	FB6	FB5	FB4	FB3	FB2	FB1	FB0	
	0x0E	FB15	FB14	FB13	FB12	FB11	FB10	FB9	FB8	
	0x0F	FB23	FB22	FB21	FB20	FB19	FB18	FB17	FB16	
	0x10	FB31	FB30	FB29	FB28	FB27	FB26	FB25	FB24	
PHASE_B	0x11	PB7	PB6	PB5	PB4	PB3	PB2	PB1	PB0	
	0x12	PB15	PB14	PB13	PB12	PB11	PB10	PB9	PB8	
SOURCE	0x13					Bsrc1	Bsrc0	ASrc1	ASrc0	
AGC_CTRL	0x14			AgcLG1	AgcLG0	AgcHldIC	AgcRstEn	AgcForce	ExpInh	
AGC_COUNT	0x15	AgcCnt7	AgcCnt6	AgcCnt5	AgcCnt4	AgcCnt3	AgcCnt2	AgcCnt1	AgcCnt0	
	0x16	AgcCnt15	AgcCnt14	AgcCnt13	AgcCnt12	AgcCnt11	AgcCnt10	AgcCnt9	AgcCnt8	
AGC_IC_A	0x17	AgcIcA7	AgcIcA6	AgcIcA5	AgcIcA4	AgcIcA3	AgcIcA2	AgcIcA1	AgcIcA0	
AGC_IC_B	0x18	AgcIcB7	AgcIcB6	AgcIcB5	AgcIcB4	AgcIcB3	AgcIcB2	AgcIcB1	AgcIcB0	
AGC_RB_A	0x19	AgcRbA7	AgcRbA6	AgcRbA5	AgcRbA4	AgcRbA3	AgcRbA2	AgcRbA1	AgcRbA0	
AGC_RB_B	0x1A	AgcRbB7	AgcRbB6	AgcRbB5	AgcRbB4	AgcRbB3	AgcRbB2	AgcRbB1	AgcRbB0	
TEST_REG	0x1B	Test7	Test6	Test5	Test4	Test3	Test2	Test1	Test0	
	0x1C			Test13	Test12	Test11	Test10	Test9	Test8	
DEBUG	0x1F	DITH_B	DITH_A	TapSel4	TapSel3	TapSel2	TapSel1	TapSel0	DebugEn	
AGC_TABLE	0x80									
	0x9F		The Agc Table loads from the low address to the high address in this order:							
F1_COEFF	0xA0		1st location, 2nd location...							
	0xB5									
F2_COEFF	0xB6		The FIR Coefficients load from the low address to the high address in this order							
	0xF5		1st location low byte, 1st location high byte, 2nd location...							

AGC Theory of Operation

A block diagram of the AGC is shown in Figure 32. The DVGA interface comprises four pins for each of the channels. The first three pins of this interface are a 3-bit binary word that controls the DVGA gain in 6dB steps (**AGAIN**). The final pin is **ASTROBE** which allows the **AGAIN** bits to be latched into the DVGA's register. A key feature of the **ASTROBE**, illustrated Figure 33, is that it toggles only if the data on **AGAIN** has changed from the previous cycle. Not shown is that **ASTROBE** and **BSTROBE** are independent. For example, **ASTROBE** should only toggle when **AGAIN** has changed. **BSTROBE** should not toggle because **AGAIN** has changed. This is done to minimize unnecessary digital noise on the sensitive analog path through the DVGA. **ASTROBE** and **BSTROBE** are asserted during **MR** and **SI** to properly initialize the DVGAs.

The absolute value circuit and the 2-stage, decimate-by-8 CIC filter comprise the power detection part of the AGC.

The power detector bandwidth is set by the CIC filter to $F_{CK}/8$. The absolute value circuit doubles the effective input frequency. This has the effect of reducing the power detector bandwidth from $F_{CK}/8$ to $F_{CK}/16$.

For a full-scale sinusoidal input, the absolute value circuit output is a dc value of $511 \cdot (2/\pi)$. Because the absolute value circuit also generates undesired even harmonic terms, the CIC filter (response shown in Figure 34), is required to remove these harmonics. The first response null occurs at $F_{CK}/8$, where F_{CK} is the clock frequency, and the response magnitude is at least 25dB below the dc value from $F_{CK}/10$ to $9F_{CK}/10$. Because the 2nd harmonic from the absolute value circuit is about 10dB below the dc this means that the ripple in the detected level is about 0.7dB or less for input frequencies between $F_{CK}/20$ to $19F_{CK}/20$.

The "FIXED TO FLOAT CONVERTER" takes the fixed point 9-bit output from the CIC filter and converts it to a "floating point" number. This conversion is done so that the 32 values in the RAM can be uniformly assigned (dB

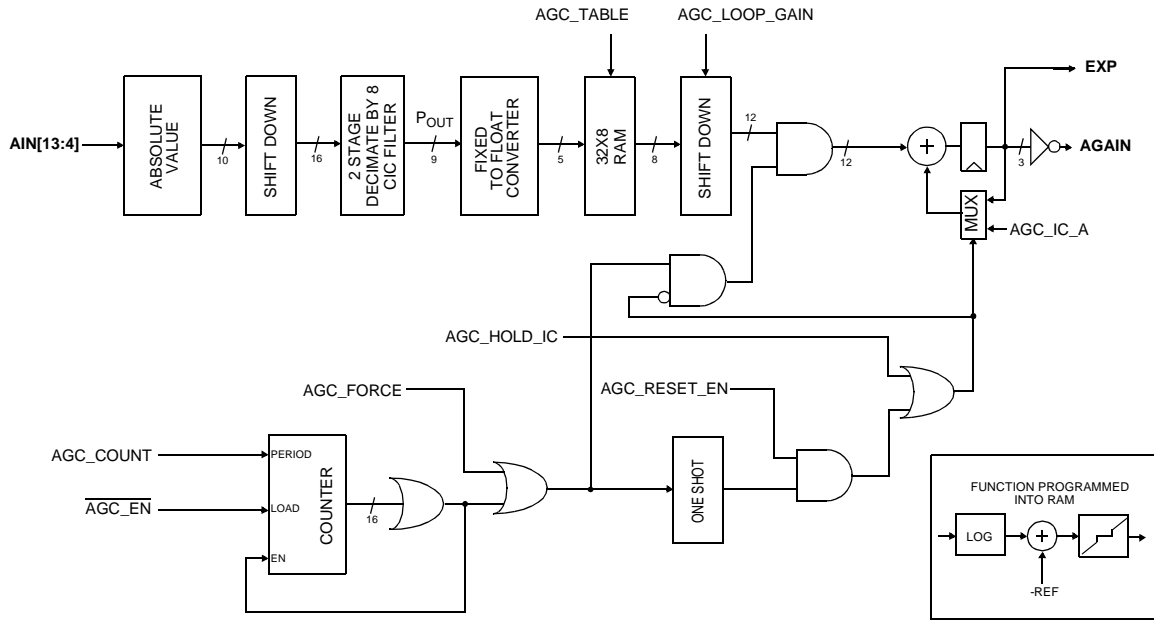

Figure 32 CLC5902 AGC circuit, Channel A

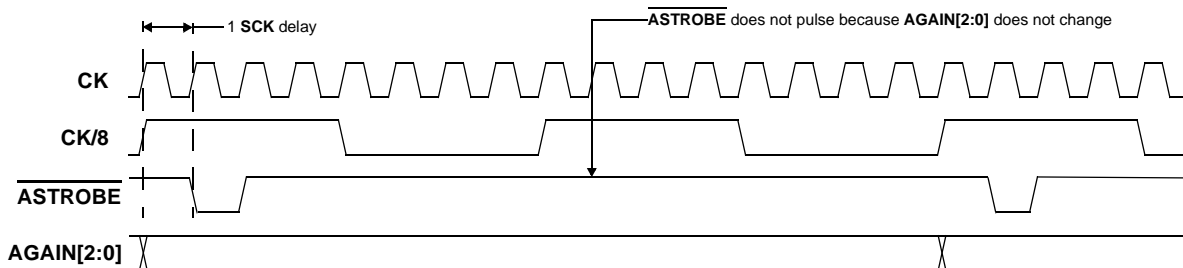

Figure 33 Timing diagram for AGC/DVGA interface, Channel A. Refer to Figure 8 for detailed timing information.

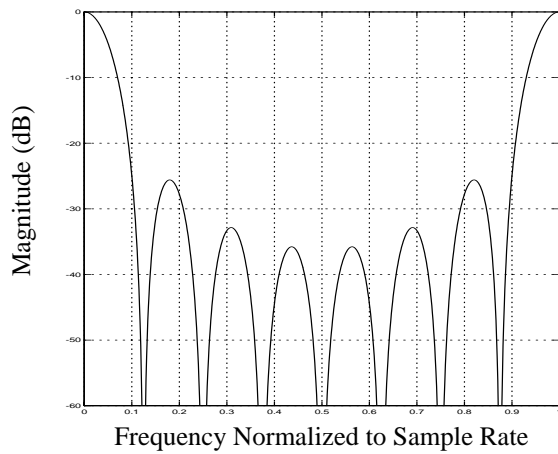

Figure 34 Power detector filter response

scale) to detected power levels (54 dB range). This provides a resolution of 1.7dB between detected power levels. The truth table for this converter is given in Table 6. The upper three bits of the output represent the exponent (e)

INPUT	OUTPUT (eeemm)
0-3	000XX
4-7	001XX
8-15	010XX
16-31	011XX
32-63	100XX
64-127	101XX
128-255	110XX
256-511	111XX

Table 6 Fixed to Float Converter Truth Table

and the lower 2 are the mantissa (m). The exponent is determined by the position of the leading '1' out of the CIC filter. An output of '001XX' corresponds to a leading '1' in bit 2 (LSB is bit 0). The exponent increases by one each time the leading '1' advances in bit position. The mantissa bits are the two bits that follow the leading '1'. If we define E as the decimal value of the exponent bits and M as the decimal value of the mantissa bits, the output of the CIC filter, P_{OUT} , corresponding to a given "FIXED TO FLOAT CONVERTER" output is,

$$P_{OUT} = [4 \cdot \min(E, 1) + M] \cdot 2^{(\max(E, 1) - 1)}, E \geq 1. \quad \text{EQ. 5}$$

The max() and min() operators account for row 1 of Table 6 which is a special case because $M=P_{OUT}$. Equation 5 associates each address of the RAM with a CIC filter output.

As shown in Figure 32, the 32X8 RAM look-up table implements the functions of log converter, reference subtraction, error amplifier, and deadband. The user must build each of these functions by constructing a set of 8-bit, 2's complement numbers to be loaded into the RAM. Each of these functions and how to construct them are discussed in the following paragraphs.

A log conversion is done in order to keep the loop gain independent of operating point. To see why this is beneficial, the control gain of the DVGA computed without log conversion is,

$$\begin{aligned} K'_{DVGA} &= \frac{\partial}{\partial G}(v_i \cdot 2^{(G-G_o)}), \\ &= -v_i \cdot \ln(2) \cdot 2^{(G-G_o)}, \end{aligned} \quad \text{EQ. 6}$$

where G is the decimal equivalent of GAIN and G_o accounts for the DVGA gain in excess of unity. This equation assumes that the DVGA gain control polarity is positive as is the case for the CLC5526. The gain around the entire loop must be negative. Observe in Equation 6 that the control gain is dependent on operating point G. If we instead compute the control gain with log conversion,

$$\begin{aligned} K_{DVGA} &= \frac{\partial}{\partial G}[20 \cdot \log(v_i \cdot 2^{(G-G_o)})], \\ &= -6.02, \end{aligned} \quad \text{EQ. 7}$$

which is no longer operating-point dependent. The log function is constructed by computing the CIC filter output associated with each address (Equation 5) and converting these to dB. Full scale (dc signal) is $20\log(511) = 54\text{dB}$.

The reference subtraction is constructed by subtracting the desired loop servo point (in dB) from the table values computed in the previous paragraph. For example, if it is desired that the DVGA servo the ADC input level (sinusoidal signal) to -6dBFS, the number to subtract from the data is

$$20\log\left(\frac{511}{2} \cdot \frac{2}{\pi}\right) = 44\text{dB} \quad \text{EQ. 8}$$

The table data will then cross through zero at the address corresponding to this reference level. A deadband wider than 6dB should then be constructed symmetrically about this point. This prevents the loop from hunting due to the 6dB gain steps of the DVGA. Any deadband in excess of 6dB appears as hysteresis in the servo point of the loop as illustrated in Figure 31. The deadband is constructed by loading zeros into those addresses on either side of the one which corresponds to the reference level.

The last function of the RAM table is that of error amplification. All the operations preceding this one gave a table slope $S_{RAM} = 1$. This must now be adjusted in order to control the time constant of the loop given by,

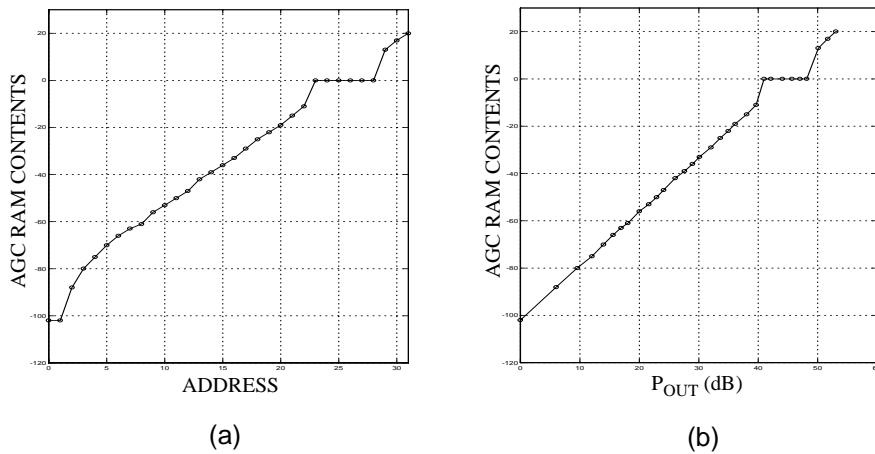

Figure 35 Example of programmed RAM contents

$$\tau = \frac{8}{F_{CK}} \left(\frac{1}{G_L} + \frac{1}{2} \right) \quad \text{EQ. 9}$$

The term G_L in this equation is the loop gain,

$$G_L = -6.02 \cdot S_{RAM} \cdot 2^{(AGC_LOOP_GAIN - 4)} \quad \text{EQ. 10}$$

The design equations are obtained by solving Equation 9 for G_L and Equation 10 for S_{RAM} . AGC_LOOP_GAIN is a control register value that determines the number of bits to shift the output of the RAM down by. This allows some of the loop gain to be moved out of the RAM so that the full output range of the table is utilized but not exceeded. The valid range for AGC_LOOP_GAIN is from 0 to 3 which corresponds to a 1 to 4 bit shift left.

An example set of numbers to implement a loop having a reference of 6dB below full scale, a deadband of 8dB, and a loop gain of 0.108 is:

```

-102 -102 -88 -80 -75 -70 -66
-63 -61 -56 -53 -50
-47 -42 -39 -36 -33 -29 -25
-22 -19 -15 -11 0
0 0 0 0 0 13 17 20

```

These values are shown plotted in Figure 35 with respect to the table addresses in (a), and the CIC filter output P_{OUT} in (b). For a 52MHz clock rate and $AGC_LOOP_GAIN=2$, these values result in a loop time constant of 1.5 μ s.

The error signal from the loop gain “SHIFT DOWN” circuit is gated into the loop integrator. The gate is controlled by a timing and control circuit discussed in the next paragraph. A MUX within the integrator feedback allows the integrator to be initialized to the value loaded into AGC_IC_A (channel B can be set independently). The conditions under which it is initialized are configured in the registers associated with the timing and control circuit. The top eight bits of the integrator output can also be read back over the microprocessor interface from the

AGC_RB_A (or AGC_RB_B) register. The top 3 bits below the sign become **AGAIN** and are output along with **ASTROBE** signal on the DVGA interface pins. The valid range of **AGAIN** is from 0 to 7 which corresponds to a valid range of 0 to $2^{10}-1$ for the 11-bit, 2’s complement integrator output from which **AGAIN** is derived. This is illustrated in Figure 36. The integrator saturates at these

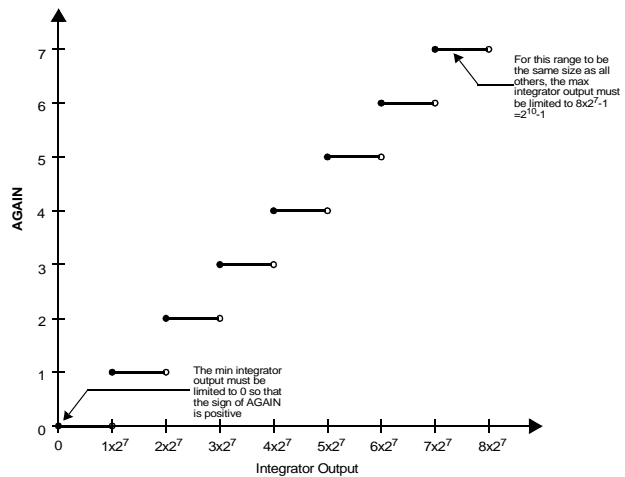

Figure 36 AGC integrator output limits

limits to prevent overshoots as the integrator attempts to enter the valid range. The **AGAIN** value is inverted (**EXP**) and used to adjust the gain of the incoming signal to provide a linear output dynamic range. The relationship between the DVGA analog gain (**AGAIN**) and the “FIXED TO FLOAT CONVERTER” digital gain (**EXP**) is shown in Table 7. The DVGA’s compression of the incoming signal in the analog domain vs. the subsequent expansion in the digital domain is shown in Figure 30.

Several control bits allow the user to configure a variety of AGC algorithms. The AGC may free run by setting AGC_FORCE high and AGC_HOLD_IC low. If a burst start pulse is available and sent to the AGC_EN pin, the

AGAIN ^a	EXP ^b	Input ^c	21	20	19	18	17	16	15	14	...	8	7	6	5	4	3	2	1	0
000 = -12dB	111 = +0dB	-12dB	14	13	12	11	10	9	8	7	...	1	0	L	L	L	L	L	L	L
001 = -6dB	110 = -6dB	-12dB	14	14	13	12	11	10	9	8	...	2	1	0	L	L	L	L	L	L
010 = +0dB	101 = -12dB	-12dB	14	14	14	13	12	11	10	9	...	3	2	1	0	L	L	L	L	L
011 = +6dB	100 = -18dB	-12dB	14	14	14	14	13	12	11	10	...	4	3	2	1	0	L	L	L	L
100 = +12dB	011 = -24dB	-12dB	14	14	14	14	14	13	12	11	...	5	4	3	2	1	0	L	L	L
101 = +18dB	010 = -30dB	-12dB	14	14	14	14	14	14	13	12	...	6	5	4	3	2	1	0	L	L
110 = +24dB	001 = -36dB	-12dB	14	14	14	14	14	14	14	13	...	7	6	5	4	3	2	1	0	L
111 = +30dB	000 = -42dB	-12dB	14	14	14	14	14	14	14	14	...	8	7	6	5	4	3	2	1	0

Table 7 15-bit Mixer Output Alignment into the 22-bit SHIFT-UP Based On EXP.^d

- a. AGAIN sets the DVGA or analog gain value.
- b. EXP sets the “FIXED TO FLOAT CONVERTER” or digital gain value.
- c. 22-bit input to SHIFT-UP block in Figure 15 horizontally, linearized SHIFT-UP value vertically.
- d. The numbers in the center of the table represent the mixer output bits. ‘L’ represents a logic low.

AGC may be configured to adapt the gain during the power ramp sequence then hold it steady afterwards by setting AGC_FORCE low, AGC_HOLD_IC low and programming AGC_HOLD_COUNT for the period of the power ramp. In addition, one can provide an initial condition and set AGC_RESET_EN high to have the gain start at a prescribed value at the beginning of each burst. The AGC becomes active when the AGC_EN pin goes low and remains active for AGC_HOLD_COUNT samples after AGC_EN goes high. The AGC_HOLD_COUNT can be programmed to one value during the random access burst and a smaller value during a normal burst. Finally, one might program a more narrow AGC loop bandwidth during normal transmission. Just prior to the next burst transmission from a mobile, set the initial condition to the value read back from the AGC accumulator at the end of the previous burst from that specific mobile. Allowing the AGC to free run should be appropriate for most applications. If the INH_EXP bit is not set, the DVGA gain word (EXP) is routed to the “FLOAT TO FIXED CONVERTER” in the DDCs prior to the programmable decimation filter. The EXP signals are delayed to account for the propagation delay of the DVGA interface and the CLC5957 ADC. The basic AGC modes are summarized in Table 4.

Evaluation Hardware

Evaluation boards are available to facilitate designs based on the CLC5902:

CLC-DRCS-PCASM

The Diversity Receiver Chipset evaluation board providing a complete narrowband receiver from IF to digital symbols.

CLC-CAPT-PCASM

A simple method for capturing output data from CLC ADCs and the CLC5902.

SOFTWARE

Control panel software for the CLC5902 supports complete device configuration on both evaluation boards.

Capture software manages the capture of data and its storage in a file on a PC.

Matlab script files support data analysis: FFT, DNL, and INL plotting.

This software and additional application information is available on the CLC Evaluation Kit CDROM.

Customer Design Applications Support

National Semiconductor is committed to design excellence. For sales, literature and technical support, call the National Semiconductor Customer Response Group at 1-800-272-9959 or fax 1-800-737-7018.

Life Support Policy

National's products are not authorized for use as critical components in life support devices or systems without the express written approval of the president of National Semiconductor Corporation. As used herein:

1. Life support devices or systems are devices or systems which, a) are intended for surgical implant into the body, or b) support or sustain life, and whose failure to perform, when properly used in accordance with instructions for use provided in the labeling, can be reasonably expected to result in a significant injury to the user.
2. A critical component is any component of a life support device or system whose failure to perform can be reasonably expected to cause the failure of the life support device or system, or to affect its safety or effectiveness.

National Semiconductor Corporation

1111 West Bardin Road
Arlington, TX 76017
Tel: 1(800) 272-9959
Fax: 1(800) 737-7018

National Semiconductor Europe

Fax: (+49) 0-180-530 85 86
E-mail: europe.support.nsc.com
Deutsch Tel: (+49) 0-180-530 85 85
English Tel: (+49) 0-180-532 78 32
Francais Tel: (+49) 0-180-532 93 58
Italiano Tel: (+49) 0-180-534 16 80

National Semiconductor Hong Kong Ltd.

2501 Miramar Tower
1 Kimberley Road
Tsimshatsui, Hong Kong
Tel: (852) 2737-1800
Fax: (852) 2736-9960

National Semiconductor Japan Ltd.

Tel: 81-043-299-2309
Fax: 81-043-299-2408

National does not assume any responsibility for use of any circuitry described, no circuit patent licenses are implied and National reserves the right at any time without notice to change said circuitry and specifications.

National Semiconductor® and  are trademarks of National Semiconductor Corporation. All other trademarks are the property of their respective companies.