

阅读申明

- 1.本站收集的数据手册和产品资料都来自互联网，版权归原作者所有。如读者和版权方有任何异议请及时告之，我们将妥善解决。
- 2.本站提供的中文数据手册是英文数据手册的中文翻译，其目的是协助用户阅读，该译文无法自动跟随原稿更新，同时也可能存在翻译上的不当。建议读者以英文原稿为参考以便获得更精准的信息。
- 3.本站提供的产品资料，来自厂商的技术支持或者使用者的心得体会等，其内容可能存在描述上的差异，建议读者做出适当判断。
- 4.如需与我们联系，请发邮件到marketing@iczoom.com，主题请标有“数据手册”字样。

Read Statement

1. The datasheets and other product information on the site are all from network reference or other public materials, and the copyright belongs to the original author and original published source. If readers and copyright owners have any objections, please contact us and we will deal with it in a timely manner.
2. The Chinese datasheets provided on the website is a Chinese translation of the English datasheets. Its purpose is for reader's learning exchange only and do not involve commercial purposes. The translation cannot be automatically updated with the original manuscript, and there may also be improper translations. Readers are advised to use the English manuscript as a reference for more accurate information.
3. All product information provided on the website refer to solutions from manufacturers' technical support or users the contents may have differences in description, and readers are advised to take the original article as the standard.
4. If you have any questions, please contact us at marketing@iczoom.com and mark the subject with "Datasheets" .

Features

- Supply-voltage Range: 2.7 V to 5.5 V
- Single-ended Output, no Balun Required
- Single-ended Input for RF and LO
- Excellent Isolation Characteristics
- Power-down Mode
- IP3 and Compression Point Programmable
- 2.5-GHz Operating Frequency

Benefits

- Reduced System Costs as only Few External Component (no Balun) are Required
- Small Package
- Very Low Current Consumption
- Easy to Use

Electrostatic sensitive device.
Observe precautions for handling.



Description

The U2795B is a 2.5-GHz mixer for WLAN and RF telecommunications equipment, e.g., DECT and PCN. The IC is manufactured using Atmel's advanced bipolar technology. A double-balanced approach was chosen to assure good isolation characteristics and a minimum of spurious products. The input and output are single-ended, and their characteristics are programmable. No output transformer or balun is required.

Figure 1. Block Diagram

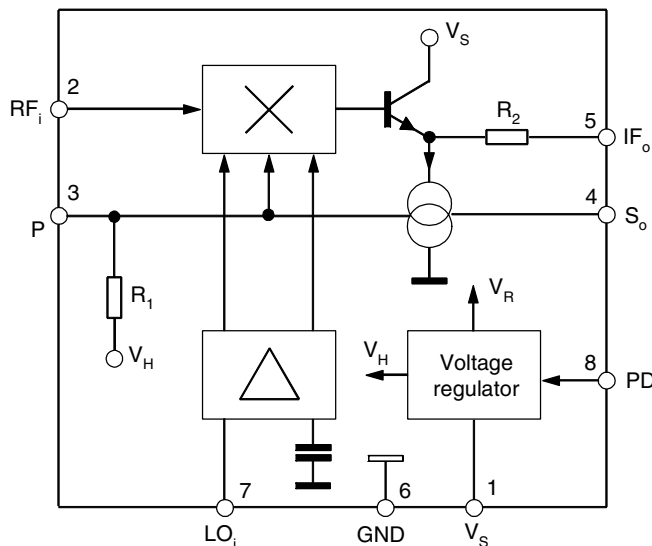

2.5-GHz Double- balanced Mixer

U2795B

Pin Configuration

Figure 2. Pinning

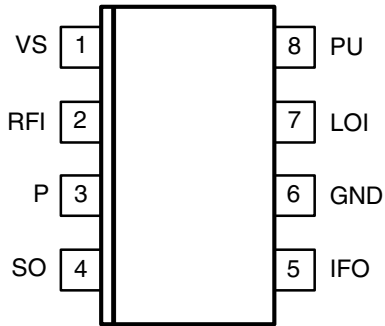

Pin Description

Pin	Symbol	Function
1	VS	Supply voltage
2	RFI	RF input
3	P	Programming port IP3, CP
4	SO	Output symmetry
5	IFO	IF output
6	GND	Ground
7	LOI	LO input
8	PU	Power-up

Functional Description

- Supply Voltage** The IC is designed for a supply-voltage range of 2.7 V to 5.5 V. As the IC is internally stabilized, the performance of the circuit is nearly independent of the supply voltage.
- Input Impedance** The input impedance, Z_{RFI} , is about 700 Ω with an additional capacitive component. This condition provides the best noise figure in combination with a matching network.
- 3rd Order Intercept Point (IP3)** The voltage divider, R_p/R_1 , determinates both the input and output intercept point, IIP3 and OIP3. If the value of R_p is infinite, the maximum value of IIP3 reach about -4 dBm. The IP3/ R_p characteristics are shown in Figure 3 and Figure 4.
- Output Impedance and Intercept Point** The output impedance is shown in Figure 11 on page 8. Both low output impedance and a high intercept point are defined to a high value of R_p .
- Current Consumption, I_S** Depending on the chosen input and output conditions of the IC, the current consumption, I_S , is between 4 mA and 10 mA. The current consumption in dependence of R_p is shown in Figure 6 on page 6.
- Power-up** This feature provides extended battery lifetime. If this function is not used, pin 8 has to be connected to V_S (pin 1).
- Output Symmetry** The symmetry of the load current can be matched and thus optimized for a given load impedance.

Absolute Maximum Ratings

Stresses beyond those listed under “Absolute Maximum Ratings” may cause permanent damage to the device. This is a stress rating only and functional operation of the device at these or any other conditions beyond those indicated in the operational sections of this specification is not implied. Exposure to absolute maximum rating conditions for extended periods may affect device reliability.

Parameters	Symbol	Value	Unit
Supply voltage	V_S	6	V
Input voltage	V_I	0 to V_S	V
Junction temperature	T_j	125	°C
Storage-temperature range	T_{stg}	-40 to +125	°C

Thermal Resistance

Parameters	Symbol	Value	Unit
Junction ambient SO8	R_{thJA}	175	K/W

Operating Range

Parameters	Symbol	Value	Unit
Supply-voltage range	V_S	2.7 to 5.5	V
Ambient-temperature range	T_{amb}	-40 to +85	°C

Electrical Characteristics

$V_S = 3\text{ V}$, $f_{LOi} = 1\text{ GHz}$, $IF = 900\text{ MHz}$, $RF = 100\text{ MHz}$, $R_P = \infty$ system impedance $Z_o = 50\ \Omega$, $T_{amb} = 25^\circ\text{C}$, $R_T = 56\ \Omega$
reference point pin 6, unless otherwise specified

No.	Parameters	Test Conditions	Pin	Symbol	Min.	Typ.	Max.	Unit	Type*
1.1	Supply voltage range		1	V_S	2.7		5.5	V	A
1.2	Supply Current	$V_S = 2.7\text{ V}$, $R_P = 10\text{ k}\Omega$	1	I_S	9		13	mA	A
		$V_S = 3.0\text{ V}$, $R_P = \infty$	1	I_S	3		6.2	mA	A
1.3	Conversion Power Gain	$R_L = 50\ \Omega$, $R_T = \infty$	1	PG_C		9		dB	B
		$R_L = 50\ \Omega$, $R_T = 56\ \Omega$		PG_C		4		dB	
2	Operating Frequencies								
2.1	RF_i frequency		2	RF_i	10		2500	MHz	D
2.2	LO_i frequency		7	f_{LOi}	50		2500	MHz	D
2.3	IF_o frequency		5	f_{IFo}	50		2500	MHz	D
3	Isolation								
3.1	LO spurious at RF_i	$P_{iLO} = -10\text{ to }0\text{ dBm}$	7, 2	IS_{LO-RF}		-30		dBm	D
3.2	RF_i to LO_i	$P_{iRF} = -25\text{ dBm}$	2, 7	IS_{RF-LO}		35		dB	D
3.3	LO spurious at IF_o	$P_{iLO} = -10\text{ to }0\text{ dBm}$	5, 7	IS_{LO-IF}		-25		dBm	D
3.4	IF_o to LO_i		5, 7	IS_{IF-LO}		30		dB	D
4	Output (IF)								
4.1	Output compression point		5	CP_O		-10		dBm	D
5	Input (RF)								
5.1	Input impedance		2	Z_{RFi}		$700\ \Omega \parallel 0.8$		$\Omega \parallel pF$	D
5.2	Input compression point		2	CP_i		-14		dBm	D
5.3	3rd-order input intercept point		2	IIP3		-4		dBm	D
6	Input (LO)								
6.1	LO level		7	P_{iLO}		-6		dBm	D
7	Voltage Standing Wave Ratio (VSWR)								
7.1	Input LO		7	$VSWR_{LOi}$		< 2			D
7.2	Output IF		4	$VSWR_{IFo}$		< 2			D
8	Noise Performance								
8.1	Noise figure	$P_{iLO} = 0\text{ dBm}$, $R_T = \infty$		NF		10		dB	D
9	Power-down Mode								
9.1	Supply current	$V_{PU} < 0.5\text{ V}$	1	I_{SPU}		< 5	30	μA	B
		$V_{PU} = 0\text{ V}$						μA	B
10	Power-down Voltage								
10.1	"Power ON"	$V_S = 3.5\text{ to }5.5\text{ V}$	8	V_{PON}	$V_S - 0.5$		$V_S + 0.5$	V	D
		$V_S = 2.7\text{ to }3.5\text{ V}$			V_S		$V_S + 0.5$	V	D
10.2	"Power DOWN"		8	V_{PDN}			1	V	D
10.3	Power-down current	Power ON	8	I_{PON}		0.15	0.22	mA	A
		Power DOWN		I_{PDN}		< 5		μA	D
10.4	Settling time		5,8	t_{SPD}		< 30		μs	D

*) Type means: A = 100% tested, B = 100% correlation tested, C = Characterized on samples, D = Design parameter

Figure 3. IIP3 versus Resistor R_p , IF: 900 MHz

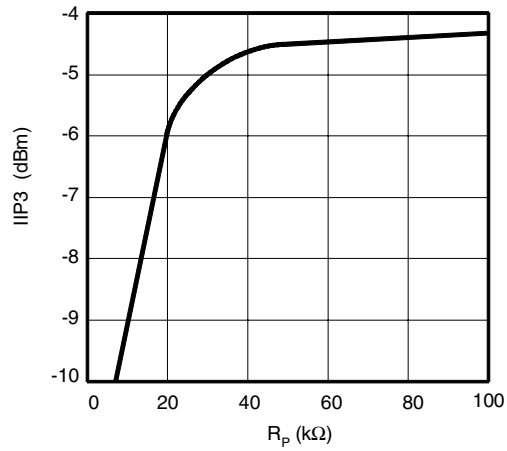

Figure 4. OIP3 versus Resistor R_p , IF: 900 MHz

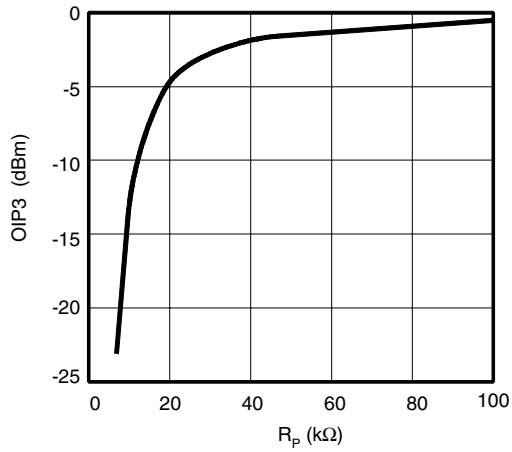

Figure 5. Gain versus Resistor R_p , LO: 1030 MHz, level -10 dBm; RF: 130 MHz, -30 dBm, $R_T = 56 \Omega$

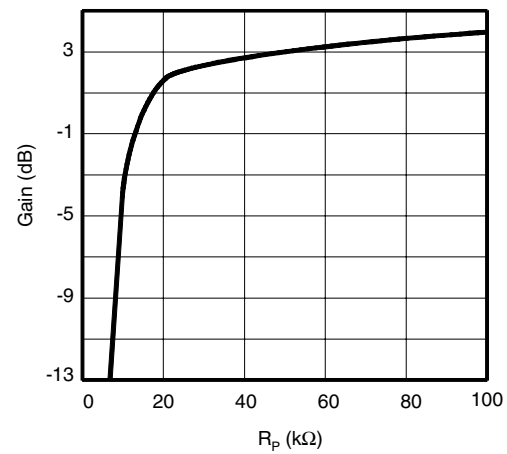

Figure 6. Supply Current I_S versus Resistor R_p

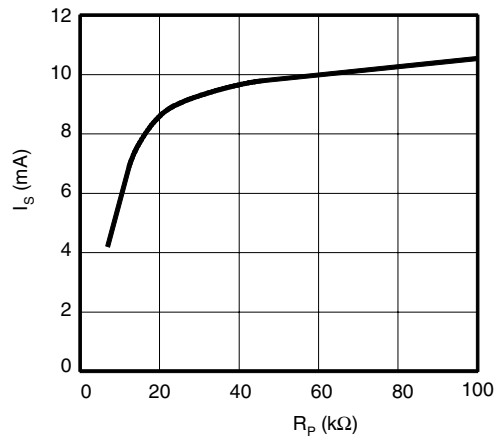

Figure 7. Gain versus IF Output Frequency, LO Level: -6 dBm, RF: 130 MHz, -35 dBm; Parameter: RF Input Termination

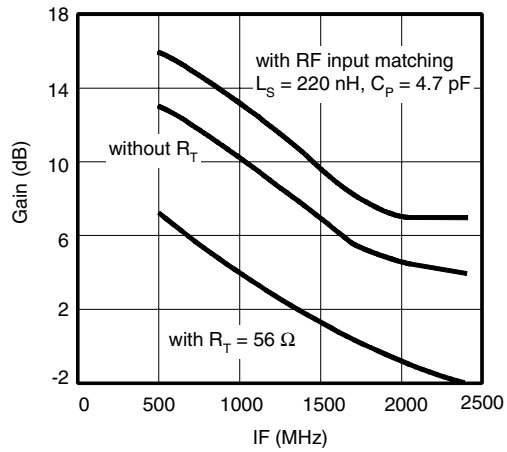

Figure 8. IIP3 versus IF Output Frequency, LO Level: -6 dBm; RF: 130 MHz/130.1 MHz, -35 dBm; Parameter: RF Input Termination

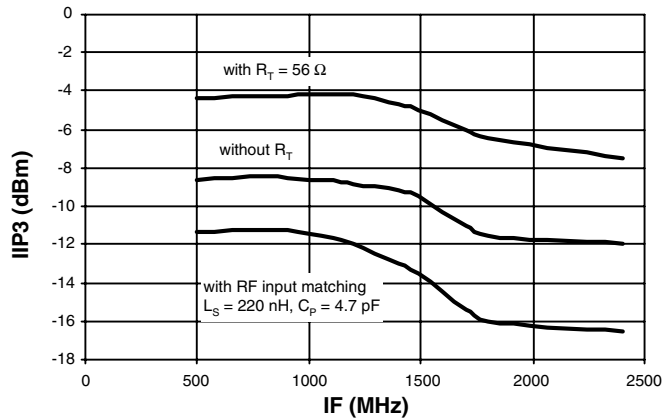

Figure 9. Double Sideband Noise Figure versus IF Output Frequency; LO: 1000 MHz, Level 0 dBm; no RF Input Matching, R_T Left Out

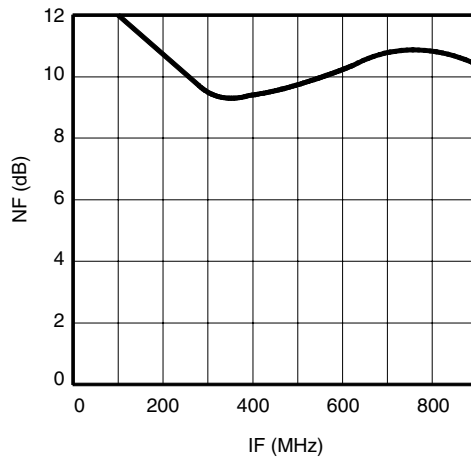

Figure 10. Typical VSWR Frequency Response of the IF Output, $R_p = \infty$

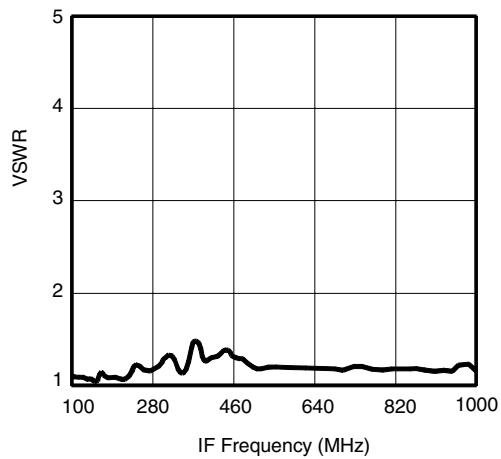

Figure 11. Typical Impedance of the Output versus R_p at Frequency $f_{IF0} = 900$ MHz
 Markers (from Left to Right): $R_p = \infty/22\text{ k}\Omega/10\text{ k}\Omega/8.2\text{ k}\Omega/5.6\text{ k}\Omega$

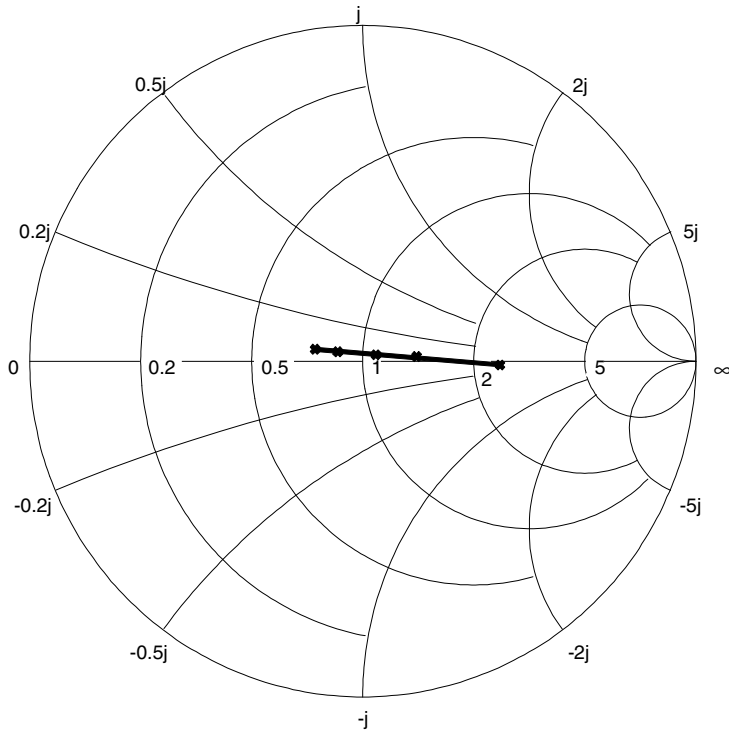

Figure 12. Typical S11 Frequency Response of the IF Output, $R_p = \infty$ IF Frequency from 100 MHz to 1000 MHz, Marker: 900 MHz

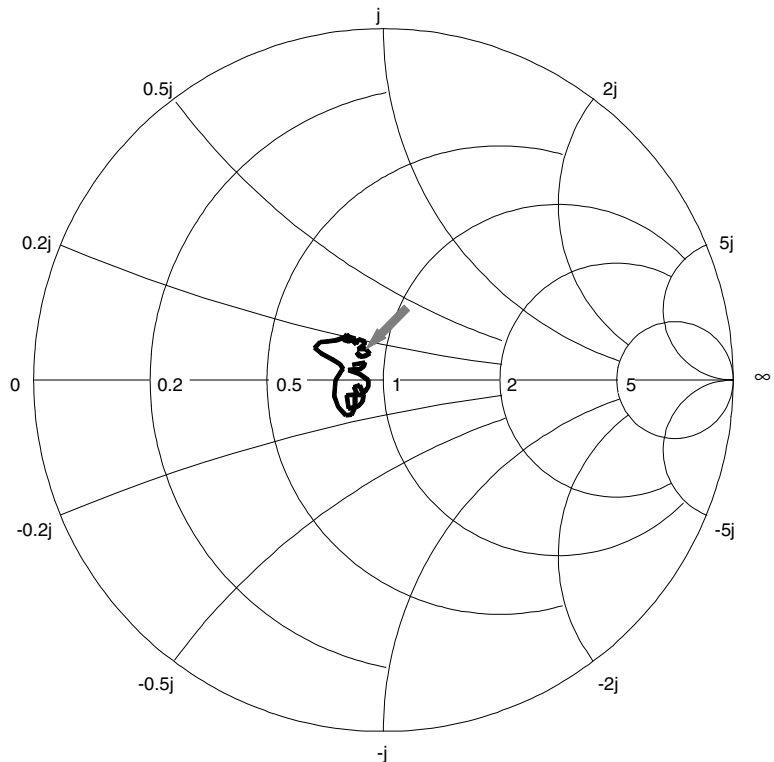

Figure 13. Typical S11 Frequency Response of the RF Input, $R_p = \infty$ $R_T = \infty$
 RF Frequency from 100 MHz to 1000 MHz, Marker: 900 MHz

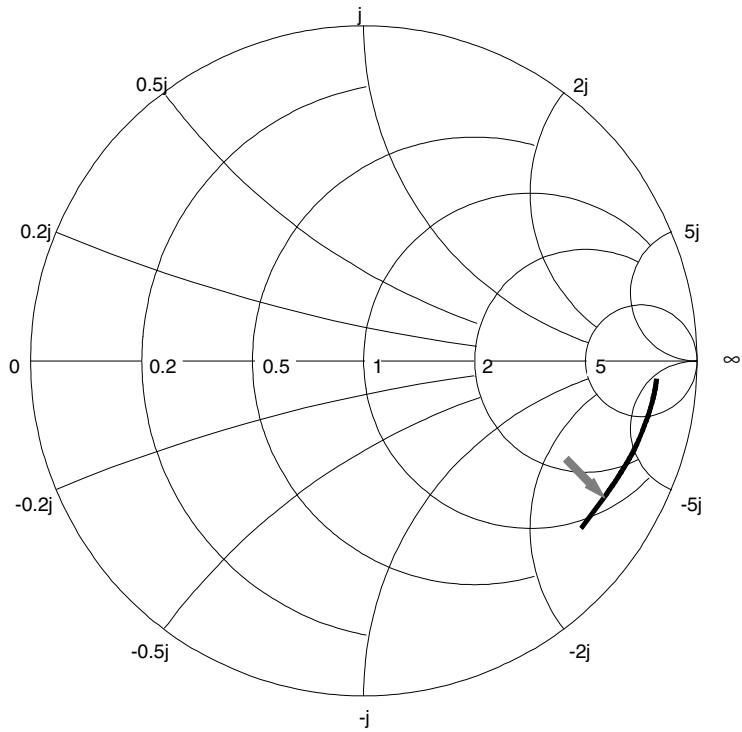
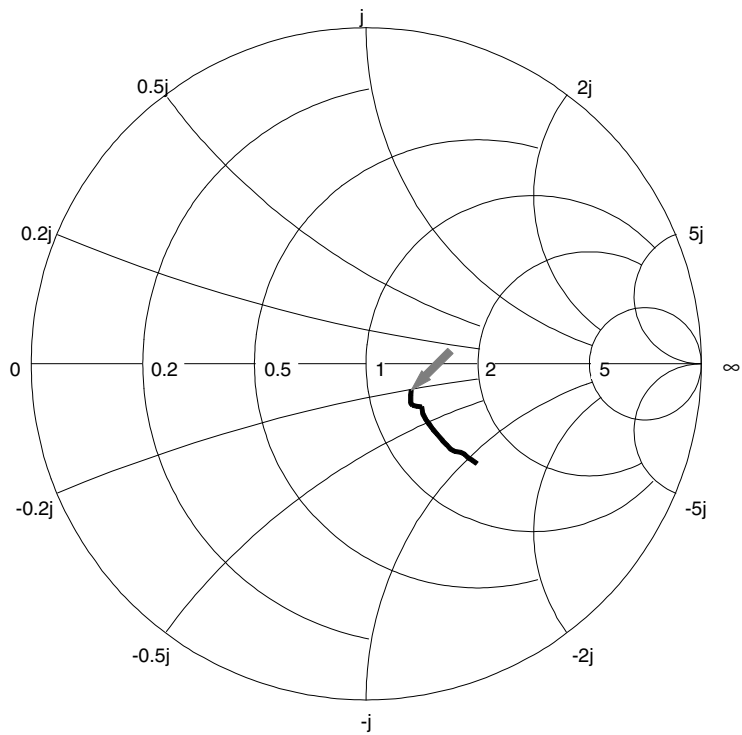

Figure 14. Typical S11 Frequency Response of the LO Input, $R_p = \infty$ LO Frequency
 from 100 MHz to 1000 MHz, Marker: 900 MHz



Application

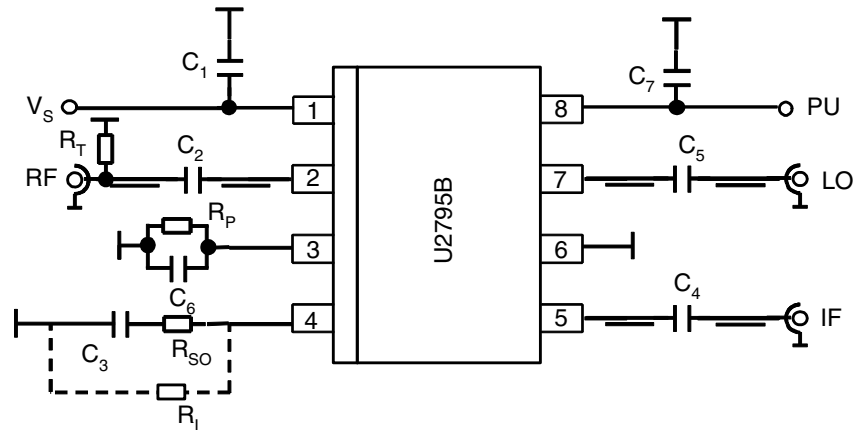

Table 1. Part List

Part	Value
C_1	10 nF
$C_2, C_3, C_4, C_5, C_6, C_7$	100 pF
$*R_P$	
	50-Ω Microstrip
$*R_{SO}$	68 Ω
	optional
R_T	56 Ω

If the part-list values are used, the PU settling time is $< 20 \mu\text{s}$. Using other values, time requirements in burst-mode applications have to be considered.

The values of R_{SO} and R_P depend on the input and output condition requirements. For R_{SO} , 68 Ω is recommended.

By means of the optional R_I , the intercept and compression point can be slightly increased; values between 500 Ω and 1 kΩ are suitable. Please note that such modification will also increase the supply current.

Application Circuit (Evaluation Board)

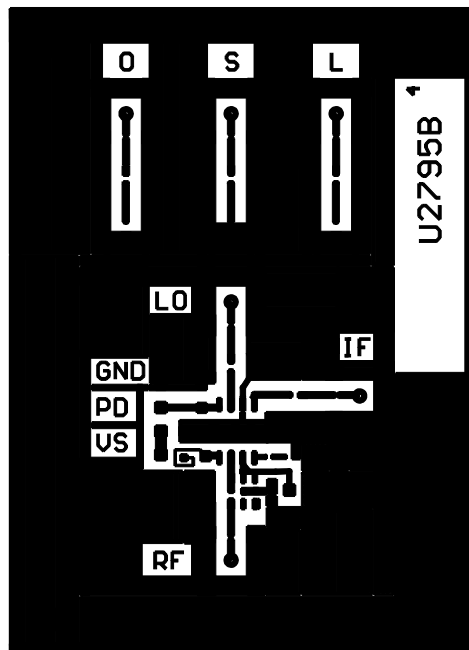
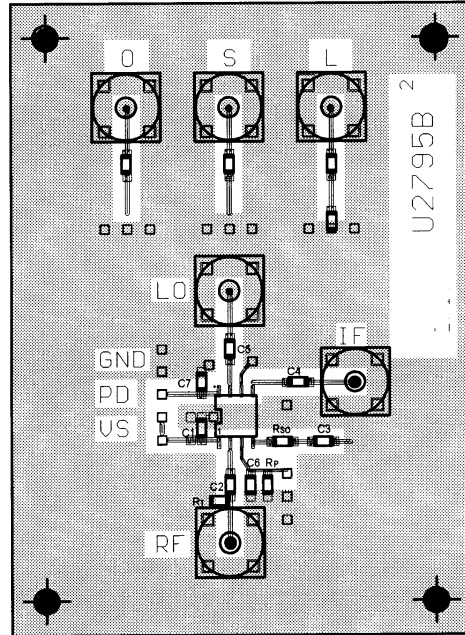



Atmel Corporation

2325 Orchard Parkway
San Jose, CA 95131, USA
Tel: 1(408) 441-0311
Fax: 1(408) 487-2600

Regional Headquarters

Europe

Atmel Sarl
Route des Arsenaux 41
Case Postale 80
CH-1705 Fribourg
Switzerland
Tel: (41) 26-426-5555
Fax: (41) 26-426-5500

Asia

Room 1219
Chinachem Golden Plaza
77 Mody Road Tsimshatsui
East Kowloon
Hong Kong
Tel: (852) 2721-9778
Fax: (852) 2722-1369

Japan

9F, Tonetsu Shinkawa Bldg.
1-24-8 Shinkawa
Chuo-ku, Tokyo 104-0033
Japan
Tel: (81) 3-3523-3551
Fax: (81) 3-3523-7581

Atmel Operations

Memory

2325 Orchard Parkway
San Jose, CA 95131, USA
Tel: 1(408) 441-0311
Fax: 1(408) 436-4314

Microcontrollers

2325 Orchard Parkway
San Jose, CA 95131, USA
Tel: 1(408) 441-0311
Fax: 1(408) 436-4314

La Chantrerie
BP 70602
44306 Nantes Cedex 3, France
Tel: (33) 2-40-18-18-18
Fax: (33) 2-40-18-19-60

ASIC/ASSP/Smart Cards

Zone Industrielle
13106 Rousset Cedex, France
Tel: (33) 4-42-53-60-00
Fax: (33) 4-42-53-60-01

1150 East Cheyenne Mtn. Blvd.
Colorado Springs, CO 80906, USA
Tel: 1(719) 576-3300
Fax: 1(719) 540-1759

Scottish Enterprise Technology Park
Maxwell Building
East Kilbride G75 0QR, Scotland
Tel: (44) 1355-803-000
Fax: (44) 1355-242-743

RF/Automotive

Theresienstrasse 2
Postfach 3535
74025 Heilbronn, Germany
Tel: (49) 71-31-67-0
Fax: (49) 71-31-67-2340

1150 East Cheyenne Mtn. Blvd.
Colorado Springs, CO 80906, USA
Tel: 1(719) 576-3300
Fax: 1(719) 540-1759

Biometrics/Imaging/Hi-Rel MPU/ High Speed Converters/RF Datacom

Avenue de Rochepleine
BP 123
38521 Saint-Egreve Cedex, France
Tel: (33) 4-76-58-30-00
Fax: (33) 4-76-58-34-80

Literature Requests

www.atmel.com/literature

Disclaimer: Atmel Corporation makes no warranty for the use of its products, other than those expressly contained in the Company's standard warranty which is detailed in Atmel's Terms and Conditions located on the Company's web site. The Company assumes no responsibility for any errors which may appear in this document, reserves the right to change devices or specifications detailed herein at any time without notice, and does not make any commitment to update the information contained herein. No licenses to patents or other intellectual property of Atmel are granted by the Company in connection with the sale of Atmel products, expressly or by implication. Atmel's products are not authorized for use as critical components in life support devices or systems.

© Atmel Corporation 2004. All rights reserved.

Atmel® and combinations thereof are the registered trademarks of Atmel Corporation or its subsidiaries.

Other terms and product names may be the trademarks of others.



Printed on recycled paper.

4654B-CELL-07/04