

阅读申明

- 1.本站收集的数据手册和产品资料都来自互联网，版权归原作者所有。如读者和版权方有任何异议请及时告之，我们将妥善解决。
- 2.本站提供的中文数据手册是英文数据手册的中文翻译，其目的是协助用户阅读，该译文无法自动跟随原稿更新，同时也可能存在翻译上的不当。建议读者以英文原稿为参考以便获得更精准的信息。
- 3.本站提供的产品资料，来自厂商的技术支持或者使用者的心得体会等，其内容可能存在描述上的差异，建议读者做出适当判断。
- 4.如需与我们联系，请发邮件到marketing@iczoom.com，主题请标有“数据手册”字样。

Read Statement

1. The datasheets and other product information on the site are all from network reference or other public materials, and the copyright belongs to the original author and original published source. If readers and copyright owners have any objections, please contact us and we will deal with it in a timely manner.
2. The Chinese datasheets provided on the website is a Chinese translation of the English datasheets. Its purpose is for reader's learning exchange only and do not involve commercial purposes. The translation cannot be automatically updated with the original manuscript, and there may also be improper translations. Readers are advised to use the English manuscript as a reference for more accurate information.
3. All product information provided on the website refer to solutions from manufacturers' technical support or users the contents may have differences in description, and readers are advised to take the original article as the standard.
4. If you have any questions, please contact us at marketing@iczoom.com and mark the subject with "Datasheets" .



Wireless Technology to Control and Monitor Anything from Anywhere™

SYNAPSE RF300 Series Engines

The RF modules called the RF300 Series Engines are a low power, highly-reliable solution to embedded wireless control and monitoring network needs that require high data rates. The RF300 embeds Synapse's SNAP OS, the industry's first Internet-enabled, wireless, mesh network operating system into the Silicon Laboratories Si1000 single-chip microcontroller with an integrated transceiver that delivers up to 150kbps. These low-cost modules can have a range of up to 3 miles and power consumption less than 2 μ A to enable a new generation of battery-driven systems.

SNAP's on-board Python interpreter provides for rapid application development and over-the-air programming, while Silicon Laboratories' low-power RF single-chip design saves board space and lowers the overall Bill of Materials and power consumption. The RF300 is approved as an FCC Part 15 unlicensed modular transmitter. The modules provide up to 16 channels of operation in the ISM 868MHz or 915MHz frequency bands. The on-board Si1000 transceiver contains both a power amplifier for transmission and a low noise amplifier in the receive path for extended range.

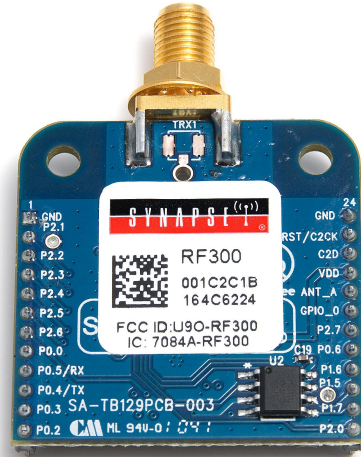

Pictured is the RF300PD1 Module

Product Features shared by all RF300 Series Engines:

- 192K total FLASH with 64K used by SNAP core, 64K free for uploadable SNAPpy scripts, and 64K reserved
- UART port for control or transparent data
- Low power modes: <16 μ A with internal timer running
- Frequency Hopping (FHSS) technology
- 150Kbps RF Data Rate
- 20 dBm Transmit Power for best-in-class range

Individual Product Features for each Module:

RF Module	Frequency Band	Antenna	Range	Certifications	I/O Pins
RF300PC1	915MHz	Chip	1 Mile	FCC, IC	15 GPIO w/12 A/D
RF300PD1	915MHz	RP-SMA	3 Miles	FCC, IC	15 GPIO w/12 A/D
RF301PC1	868MHz	Chip	1 mile	CE	15 GPIO w/12 A/D



RF300 Series Engines

Physical Dimensions for the RF300PD1

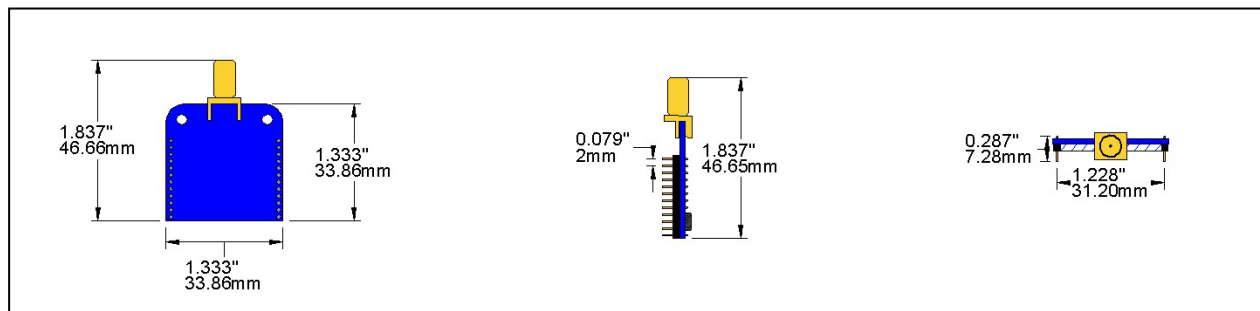

RF300 Series Module Pin Assignments		
Pin	Name	Description
1	GND	Power Supply
2	GPIO0/ADC17/P2.1	GPIO_0, ADC17, I ² C SDA
3	GPIO1/ADC18/P2.2	GPIO_1, ADC18, I ² C SCL
4	GPIO2/ADC19/P2.3	GPIO_2, ADC19
5	GPIO3/ADC20/P2.4	GPIO_3, ADC20
6	GPIO4/ADC21/P2.5	GPIO_4, ADC21, SPI MOSI
7	GPIO5/ADC22/P2.6	GPIO_5, ADC22, SPI SCLK
8	GPIO6/ADC0/P0.0/V _{REF}	GPIO_6, ADC0, Interrupt, External Voltage Reference, SPI MISO
9	GPIO7/ADC5/P0.5/UART_RX	GPIO_7, ADC5, Interrupt, UART0 Rx Data Input
10	GPIO8/ADC4/P0.4/UART_TX	GPIO_8, ADC4, Interrupt, UART0 Tx Data Output
11	GPIO9/ADC3/P0.3/CTS	GPIO_9, ADC3, UART0 CTS Output
12	GPIO10/ADC2/P0.2/RTS	GPIO_10, ADC2, Interrupt, UART0 RTS Input
13	[GPIO11/ADC16/P2.0]	Not Available, Do Not Connect ¹
14	[GPIO12/ADC15/P1.7]	Not Available, Do Not Connect ¹
15	[GPIO13/ADC13/P1.5]	Not Available, Do Not Connect ¹
16	[GPIO14/ADC14/P1.6]	Not Available, Do Not Connect ¹
17	GPIO15/ADC6/P0.6/CNVSTR	GPIO_15, ADC6, External "Start Conversion" for ADC0
18	GPIO16/P2.7	GPIO_16 ²
19	GPIO17	GPIO_17
20	ANT_A	GPIO_18 (Output Only)
21	VCC	Power Supply
22	C2D	Background Debug Communications
23	RESET	Module Reset, Active Low
24	GND	Power Supply

¹ Pins 13 – 16 are not available for use on the RF300 and should not be tied to any signals. These pins are used for access to the onboard external memory.

² GPIO16 has limited drive strength as it is routed through a 1Kohm resistor. The signal driven from (or to) GPIO16 can also be read, or driven, on pin 22 (CD2), the debug pin.