

阅读申明

- 1.本站收集的数据手册和产品资料都来自互联网，版权归原作者所有。如读者和版权方有任何异议请及时告之，我们将妥善解决。
- 2.本站提供的中文数据手册是英文数据手册的中文翻译，其目的是协助用户阅读，该译文无法自动跟随原稿更新，同时也可能存在翻译上的不当。建议读者以英文原稿为参考以便获得更精准的信息。
- 3.本站提供的产品资料，来自厂商的技术支持或者使用者的心得体会等，其内容可能存在描述上的差异，建议读者做出适当判断。
- 4.如需与我们联系，请发邮件到marketing@iczoom.com，主题请标有“数据手册”字样。

Read Statement

1. The datasheets and other product information on the site are all from network reference or other public materials, and the copyright belongs to the original author and original published source. If readers and copyright owners have any objections, please contact us and we will deal with it in a timely manner.
2. The Chinese datasheets provided on the website is a Chinese translation of the English datasheets. Its purpose is for reader's learning exchange only and do not involve commercial purposes. The translation cannot be automatically updated with the original manuscript, and there may also be improper translations. Readers are advised to use the English manuscript as a reference for more accurate information.
3. All product information provided on the website refer to solutions from manufacturers' technical support or users the contents may have differences in description, and readers are advised to take the original article as the standard.
4. If you have any questions, please contact us at marketing@iczoom.com and mark the subject with "Datasheets" .

ITEM 01:

REFER TO 0097-0934 FOR ALL
DIMENSIONS NOT SHOWN.
NOTE: LESS NOTCHES

THIS INFORMATION IS CONFIDENTIAL AND PROPRIETARY TO LAIRD TECHNOLOGIES.
IT MAY NOT BE DISCLOSED TO ANYONE, OTHER THAN LAIRD TECHNOLOGIES
PERSONNEL, WITHOUT WRITTEN AUTHORIZATION FROM LAIRD TECHNOLOGIES.

DWG. NO.	0097-0954
REDRAWN & REVISED, OP'S REVISED, K.D. JNS 11-25-85	05
OP#1 WAS 97-931.1 NOTCH, PIERCE & CUT OFF-ADDED REFER NOTE & MFG. NOTES. .150 WAS 3/16 TA WHS 7-28-86	06
SEE DWG 0097-C-0931 REMOVED FROM ITEM 01 MAT'L. MFG. NOTES REMOVED. TA WHS 9-3-86	07
14.978 +.012 /-.020 WAS 15±.030 .000-.003 ADDED. PARTIAL FINGERS REMOVED. K.D. WHS 9-3-86	08
ECN 3668 ADD SIZE OP. RCC 5-26-89 ES 5-30-89	09
ECN 5185 ADD ANGULAR TOL. TO LEGS. RCC 4-11-90 EWS 4-11-90	10
ECN 5231 OP#1 WAS NOTCH, PIERCE & CUT-OFF. REMOVE (2) FORM OP'S. ADD 'Z' FORM. RCC 6-5-90 EWS 6-6-90	11
ECN 6174 DELETE SIZE OP. RCC 6-26-91 EWS 6-27-91	12
.110 WIDE TAPE WAS .150 WIDE. JCH 3/15/92 ES 3-17-92	13
ECN 8564 REMOVED OPS. BMG 11-5-93 EWS 11-8-93	14

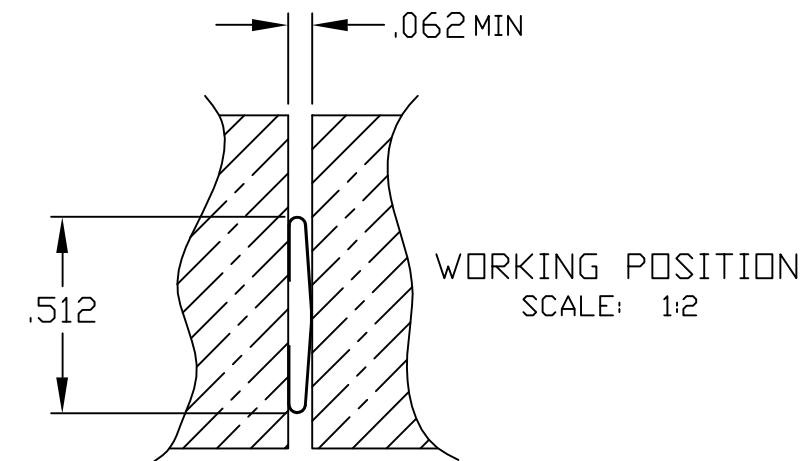
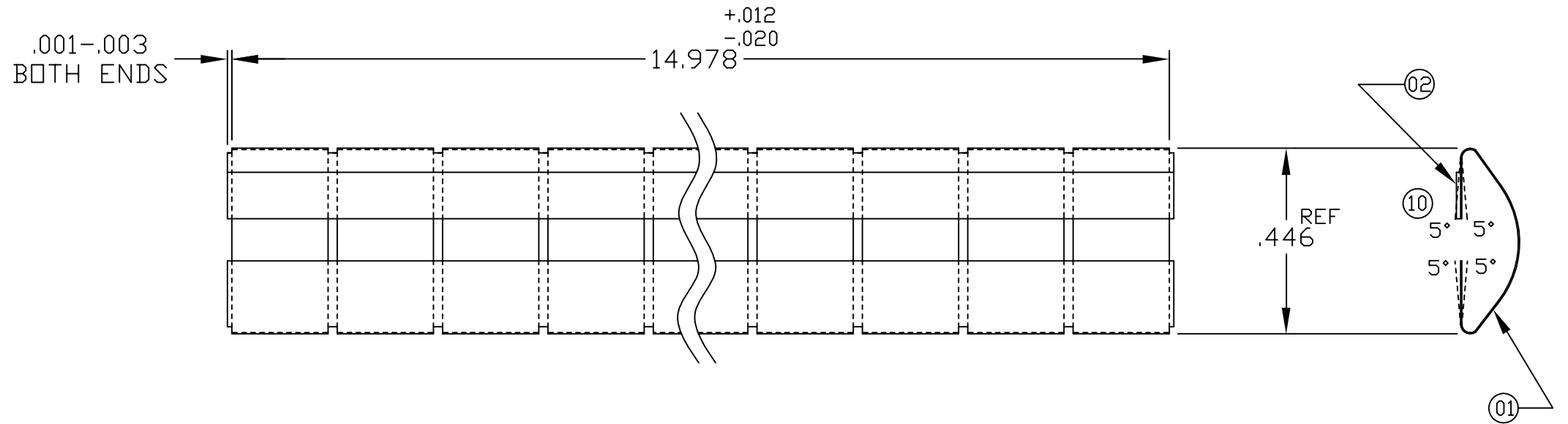

ITEM	MATERIAL	MATERIAL:	SEE CHART	TOLERANCES NOT SHOWN		DRAWN BY:	DATE:
01	.003 X .902 BeCu REF.	HEAT TREATED:	TO DPH 383 MIN USING A 500 GRAM LOAD	DECIMAL 2 PL'S ± .010 DECIMAL 3 PL'S ± .010		KD	11/19/85
13 02	.110 WIDE PRESSURE SENSITIVE TAPE-SEE DWG. 0097-0446	THICKNESS AFTER:	CLEANING: .0026 MIN.	ANGULAR ± ---	DELAWARE WATER GAP PENNSYLVANIA	CHECKED BY:	DATE:
		FINISH:	AS REQUIRED	THIRD ANGLE PROJECTION		RKM	12/05/01
				UNITS: INCH [MM]		APPROVED BY:	DATE:
				SCALE: 3:1		ES	12/05/01
						LAIRD STANDARD	
						REF. DWG NO. 0097-0934	
		DWG. NO.	0097-0954			DWG. NO.	SUB
				CAD MAINTAINED DRAWING. MANUAL CHANGES UNAUTHORIZED.		0097-0954	14

B