

阅读申明

- 1.本站收集的数据手册和产品资料都来自互联网，版权归原作者所有。如读者和版权方有任何异议请及时告之，我们将妥善解决。
- 2.本站提供的中文数据手册是英文数据手册的中文翻译，其目的是协助用户阅读，该译文无法自动跟随原稿更新，同时也可能存在翻译上的不当。建议读者以英文原稿为参考以便获得更精准的信息。
- 3.本站提供的产品资料，来自厂商的技术支持或者使用者的心得体会等，其内容可能存在描述上的差异，建议读者做出适当判断。
- 4.如需与我们联系，请发邮件到marketing@iczoom.com，主题请标有“数据手册”字样。

Read Statement

1. The datasheets and other product information on the site are all from network reference or other public materials, and the copyright belongs to the original author and original published source. If readers and copyright owners have any objections, please contact us and we will deal with it in a timely manner.
2. The Chinese datasheets provided on the website is a Chinese translation of the English datasheets. Its purpose is for reader's learning exchange only and do not involve commercial purposes. The translation cannot be automatically updated with the original manuscript, and there may also be improper translations. Readers are advised to use the English manuscript as a reference for more accurate information.
3. All product information provided on the website refer to solutions from manufacturers' technical support or users the contents may have differences in description, and readers are advised to take the original article as the standard.
4. If you have any questions, please contact us at marketing@iczoom.com and mark the subject with "Datasheets" .

- Creates 4 'touch buttons' through any dielectric
- Only 1 inexpensive capacitor required
- Simple 4x1 matrix key geometry
- 100% drift compensation for lifetime reliability
- '2' key rollover: senses any 2 keys at same time
- Back-lit keys possible with ITO electrodes
- Simple direct 'per key' active-high drive outputs
- Auto recalibration after 10 or 60 seconds of touch
- 2.5 - 5.5V single power supply operation
- CMOS design - very low power consumption
- 14-pin SOIC package
- E604 Evaluation reference design board available

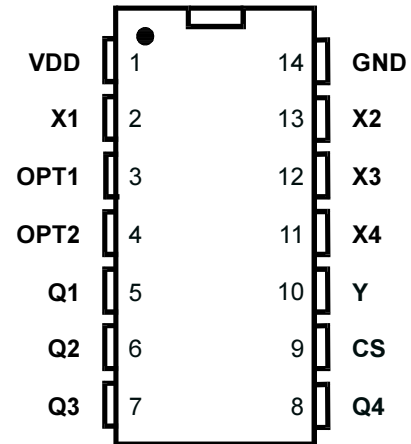

APPLICATIONS -

- | | | | |
|------------------------|------------------------|-----------------|----------------------------|
| ◆ Security keypanels | ◆ Appliance controls | ◆ ATM machines | ◆ Automotive controls |
| ◆ Industrial keyboards | ◆ Vandal-proof keypads | ◆ Touch-screens | ◆ PC / peripheral controls |

The QT60040 digital charge-transfer ("QT") QMatrix™ IC is designed to detect touch on up to 4 keys in a scanned 4x1 matrix. It will project the keys through almost any dielectric, like glass, plastic, stone, ceramic, and even most kinds of wood, up to thicknesses of 6mm. The touch areas are defined as simple 2-part interdigitated electrodes of conductive material, like copper, Indium-Tin-Oxide (ITO), or screened silver or carbon deposited on the rear of a control panel. Alternatively the keys can be implemented on a stick-on flex circuit that can be adhered to the rear of most panels.

The IC is designed specifically for domestic appliances, computer and peripheral control buttons, ATM machines, security panels, portable instruments, machine tools, or similar products that are subject to environmental challenges or physical attack. It permits the construction of 100% sealed, watertight keypanels that are immune to environmental factors such as humidity and condensation, temperature, dirt accumulation, or the physical deterioration of the panel surface from abrasion, chemicals, or abuse. The QT60040 contains Quantum-pioneered self-calibration, drift compensation, and digital filtering algorithms that make its sensing function extremely robust and survivable.

The device can easily control keys over graphical LCD panels or LEDs when used with clear, conductive ITO electrodes. It does not require 'chip on glass' or other exotic fabrication techniques, thus allowing the OEM to source the keymatrix from multiple vendors.

External circuitry consists only of a single, inexpensive capacitor. The sensitivity of the keys can be set by simply changing the value of this capacitor. The device has 4 outputs which indicate detection on the keys; up to 2 keys can be sensed at any one time.

The QT60040 features automatic recalibration timeouts which will cause the device to recalibrate keys on an individual basis when they are 'stuck on' for intervals of either 10s or 60s, depending on a jumper option.

QT60040 technology makes use of an important new variant of charge-transfer sensing, transverse charge-transfer, in an XY format that minimizes the number of required scan lines and external components. Unlike older technologies it does not require one IC per key, and is cost competitive even with some rubber membrane technologies. A distinct advantage is an accelerated time to market due to the fact that custom molded membranes are not required; the entire system can be designed using common PCB materials.

The E604 board available from Quantum is a reference design that permits full evaluation of the QT60040

AVAILABLE OPTIONS

T _A	SOIC	DIP
0°C to +70°C	-	QT60040-D
-40°C to +85°C	QT60040-IS	-

1 - OVERVIEW

The QT60040 is a CMOS charge-transfer (QT) sensor designed specifically for matrix touch controls; it includes all signal processing functions necessary to provide stable sensing under a wide variety of changing conditions. Only one low cost external capacitor is required for operation.

The QT60040 uses burst-mode charge transfer methods pioneered and patented by Quantum. This revolutionary new technology allows the construction of entirely new forms of

Figure 1-1 Field flow between X and Y elements

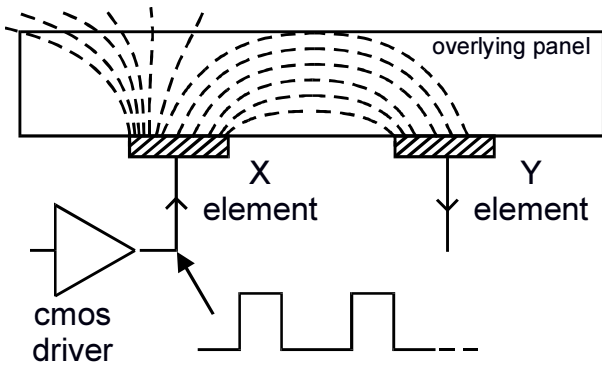

keypansels which can include back-illumination, arbitrary shapes of keys, 'morphed' keys wrapped onto complex surfaces, and keys having unique textures and feel, all at very low cost.

The QT60040 uses a 4x1 matrix, having 4 'X' drive lines and 1 'Y' receive line. This configuration reduces interconnect requirements and also lowers the external component count to one charge sampling capacitor which is sequentially shared by the four keys.

The QT60040 has four simple active-high CMOS outputs that go high when the corresponding key is touched. Up to 2 keys can be touched at the same time; three or more keys touched will limit to the first two touch outputs. An option pin allows this to be restricted to only one key if desired.

The device operates on a 2.5 to 5.5 regulated power supply which can be from a common 78L05-type IC regulator or a simple 2-stage zener regulator supply.

1.1 FIELD FLOWS

Figure 1-1 shows how charge is transferred across an electrode set to permeate the overlying panel material; this charge flow exhibits a rapid dQ/dt during the edge transitions of the X drive pulse. The charge emitted by the X electrode is partly received onto the Y electrode which is then captured by the C_s capacitor and processed.

The QT60040 matrix uses 4 'X' edge-driven rows and 1 'Y' sense column to detect 4 keys. The X drive occurs as a burst of pulses on each key.

The charge flows set into motion by the X drive signals are partially absorbed by the touch of a human finger (Figure 1-2) resulting in a decrease in coupling from X to Y; coupled charge increases in the presence of a conductive film like water (Figure 1-3) which acts to bridge the two elements. Increasing signals due to water films are quite easy to discern and are not detected by the QT60040.

1.2 CIRCUIT MODEL

An electrical circuit model is shown in Figure 1-4. The coupling capacitance across the X and Y electrodes and from each to a finger is represented by C_{x1} , C_{x2a} , and C_{x2b} . The sampling capacitor C_s is used to accumulate charge during the course of a burst. An important parasitic capacitance from the Y line to ground, C_{x3} , is also shown.

QT switch timing action is shown in Figure 1-5.

Initially, switch S_3 is closed to reset C_s then re-opened. After S_3 is opened, S_1 is closed to charge the capacitances associated with the Y-line, including all Y-to-X capacitances. After S_1 is closed, one of the four X lines is raised high, so that there is then a zero differential potential from the selected X line to the Y line. Then, S_1 is opened and S_2 is closed, causing charge to flow from the C_x capacitances into C_s ; C_s charges up slightly with the polarity shown. Then the selected X line is driven low, causing a step-function decrease in charge on C_s whose magnitude is proportionate to the amount of coupling from X to Y.

The final charge accumulated on C_s per QT cycle is thus a direct function of $C_{x1} / C_{x2a} / C_{x2b} / C_{finger}$ network. Since the charge from the C_{x2a} / C_{x2b} network is highly dependent on C_{finger} , which effectively forms a capacitive divider, the total charge absorbed by C_s is dependent on touch: a touch nets more charge transferred into C_s per QT cycle because less charge is transferred out of C_s per QT cycle.

The acquisition process is controlled by a state machine which continues the acquisition cycle as a burst, which finally terminates when the voltage across C_s reaches the predefined level V_{ref} . This burst takes hundreds or even thousands of cycles

Figure 1-2 Field Flows When Touched

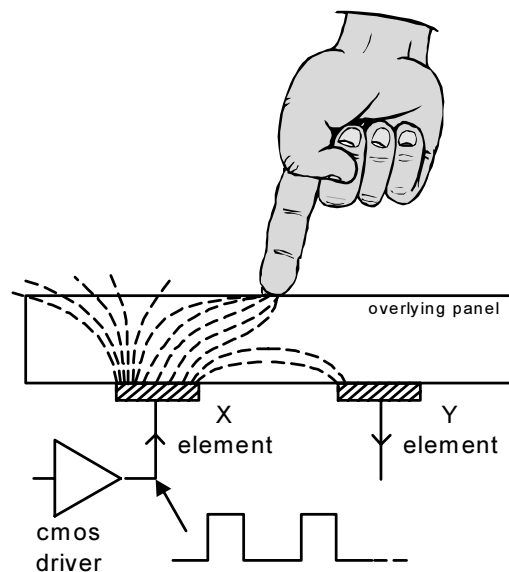

Figure 1-3 Fields With a Conductive Film

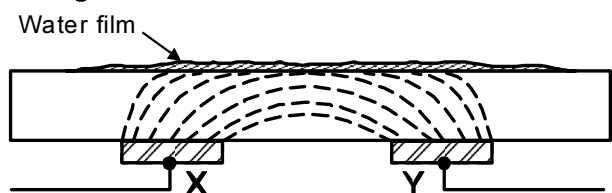

Figure 1-4 QT60040 Circuit Model

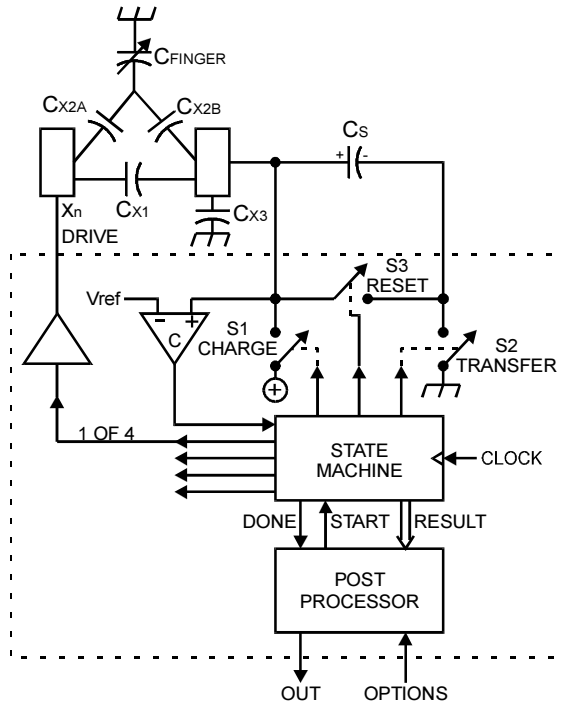
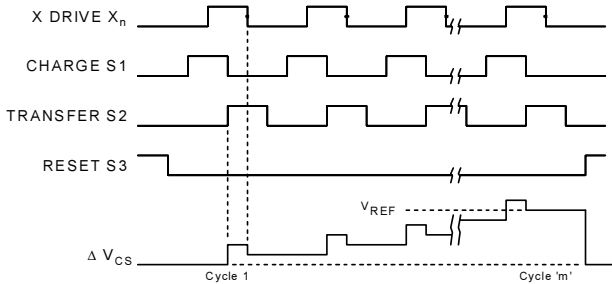

Figure 1-5 Circuit Switch Timings



to complete; the burst length depends on the value of C_s , the C_x capacitances, and C_{finger} . Increasing C_s increases the burst length, increasing C_{x3} decreases burst length, and increasing C_{x1} and C_{x2} increase burst length. Increasing C_{finger} decreases the burst length. The value of the burst length is thus a variable that is dependent on these capacitances; the burst length is used to create an internal reference signal level during a calibration cycle, and to determine the presence of touch by virtue of a change in the burst length relative to the reference level.

Because the C_s capacitor is shared among all four channels it is important that the four interdigitated key designs be reasonably well matched. It is also important to keep C_{x1} and C_{x3} to a minimum while maximizing the values of C_{x2a} and C_{x2b} through good key design methods. These requirements also dictate that the IC be placed close to the keys to achieve good sensitivity levels; long Y traces also increase the risk of susceptibility to interference, as well as low gain. To reduce C_{x3} , the Y line should not be run close to other unrelated traces or over or near ground planes.

1.3 SINGLE ELECTRODE OPERATION

An alternative mode of operation is shown in Figure 1-6. Capacitances C_{x2a} and C_{x2b} are implemented as discrete

Figure 1-6 Conversion to Single Electrodes

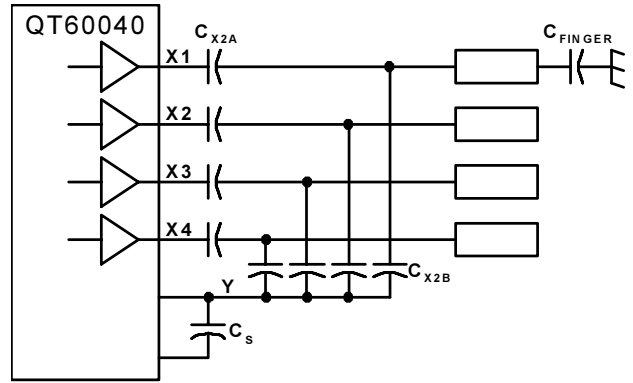

capacitances, possibly by using intentional mutual capacitive coupling of tracks on a PCB; traces from the intersections of these capacitors are led to solid touch pads which are implemented as metallizations on the rear of a control panel. Touching the front of the panel has the same absorptive effect on signal strength as an interdigitated electrode set.

The values of C_{x2a} and C_{x2b} should be consistent among all keys to preserve signal balance, which is required for proper operation. The surface area and geometry of this type of electrode should be adjusted to suit the desired activation area.

Typical values of C_{x2a} and C_{x2b} range from 5pF to 10pF. The traces leading from the junctions of these capacitors to the solid touch pads should not see a load of more than 10pF, thus the traces to these pads should be thin and short and not accompanied by a ground plane or other traces.

1.4 INTERDIGITATED ELECTRODES

Key electrodes can be made using interdigitated sets of fingers, serpentes, spirals or similar patterns (Figure 1-7). One element of each key must be connected to an X line, with the other connected to the common Y line. The pattern surface area should be similar from key to key to preserve relative key sensitivities.

It is important to prevent substantial capacitive coupling from a 'bare' Y line to a finger. A transient increase in C_{x3} will cause a sudden disturbance common to all keys that can create unintentional detections. The connecting Y trace running between the keys should be as thin as possible, on a side of the flex circuit or pcb away from the user panel, and where possible run closely in parallel with a segment of a nearby X trace so as to suppress this effect. The problem of a bare Y line can be demonstrated by touching the C_s capacitor (which is connected to Y), which will cause one or two random keys to activate with each touch.

In cases where it is not possible to have both the X and Y traces on the same plane, the X traces should be run on the 'finger' side of the board. In all cases where the X and Y lines run on opposite planes, the substrate (a flex circuit, or a pcb) should be as thin as

Figure 1-7 Sample Electrode Geometries

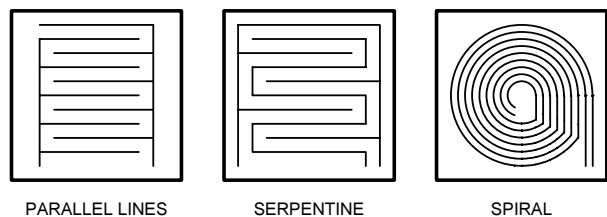

possible to promote equal field coupling through the overlying panel material and to increase sensitivity.

Suggested design rules for interdigitated keys are shown in Figure 1-8.

1.5 SIGNAL PROCESSING

The QT60040 calibrates and processes all signals using a number of algorithms pioneered by Quantum. These algorithms are specifically designed to survive most environmental conditions.

1.5.1 SELF-CALIBRATION

The QT60040 is fully self-calibrating. On powerup it scans the matrix and sets appropriate calibration points for each. No special operator or factory calibration or circuit tweak is required to bring keys into operation. The self calibration procedure typically requires 1 second to complete.

1.5.2 DRIFT COMPENSATION ALGORITHM

Signal drift can occur because of changes in Cx and Cs over time. It is crucial that drift be compensated for, otherwise false detections, non-detections, and sensitivity shifts will follow.

Drift compensation (Figure 1-9) is performed by making the reference level track the raw signal at a slow rate, but only while there is no detection in effect. The rate of adjustment is performed slowly, otherwise legitimate detections might be ignored. The QT60040 drift compensates using a slew-rate limited change to the reference level; the threshold and hysteresis values are slaved to this reference.

The QT60040's drift compensation is 'asymmetric': the drift-compensation occurs in one direction faster than it does in the other. Specifically, it compensates faster for decreasing loads. Increasing loads (more contact with an object, which results in a decreasing signal) should be compensated for slowly, so that sensitivity to an approaching finger is not affected. Removal of an object is compensated for at a faster rate to allow the sensor to recover quickly to prepare for the next valid touch.

1.5.3 THRESHOLD AND HYSTERESIS CALCULATIONS

The threshold value is established as an offset to the reference level. As Cx and Cs drift over time, the reference drift compensates with the changes and the threshold level is automatically recomputed in real time so that it is never in error. Since key touches result in negative signal swings, the threshold is set below the signal reference level.

The QT60040 employs a hysteresis of 25% of the delta between the reference and threshold levels. The signal must rise by 25% of the distance from threshold to reference before the detection event drops out and the key registers as untouched.

1.5.4 MAX ON-DURATION

If a foreign object contacts a key the signal may change enough to create a detection lasting for the duration of the contact. To overcome this, the part includes individual key timers which monitor detection duration. If a detection on a key exceeds the timer limit setting, the sensor will perform a full recalibration. This is known as the Max On-Duration feature.

After the Max On-Duration interval has expired and the recalibration has taken place, the key will once again function normally even if still in contact with the foreign object, to the best of its ability. The Max On-Duration can be set to either 10 or 60 seconds of continuous

detection by a jumper option (Table 2-1); this option applies to all keys.

Max On-duration has no interaction among keys; a timeout on one key will have no effect on another key.

1.5.5 DETECTION INTEGRATOR

To suppress false detections caused by spurious events like electrical noise, the QT60040 incorporates a detection integration counter that increments with each detection sample until a limit is reached, at which point a detection is confirmed. If no detection is sensed on any of the samples prior to the final count, the counter is reset immediately to zero, forcing the process to restart. The required count is 3 samples per key.

Figure 1-8 Key Design Rules

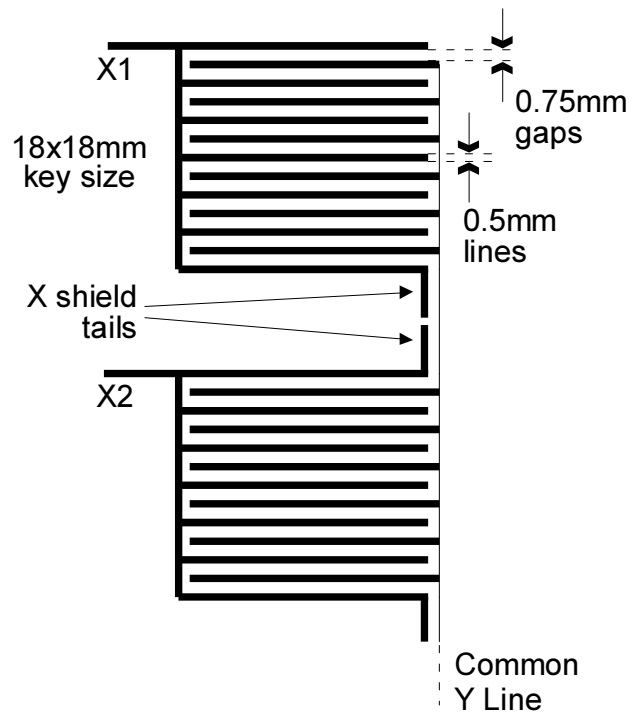

Figure 1-9 Drift Compensation

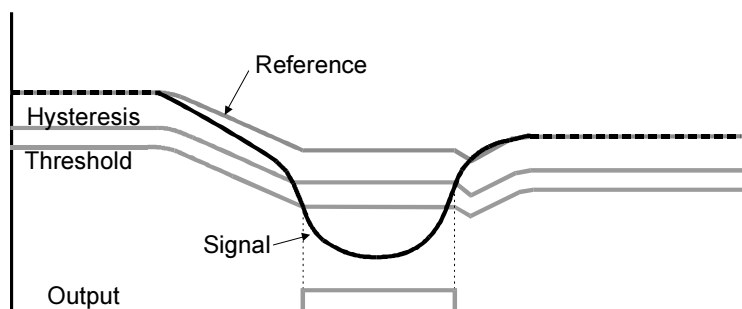
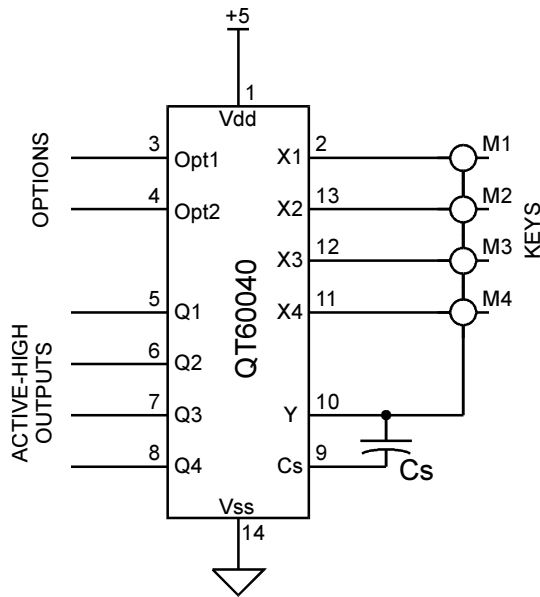

Figure 2-1 Basic Circuit Diagram



2 - CIRCUIT SPECIFICS

The basic QT60040 circuit is shown in Figure 2-1.

2.1 Cs CAPACITOR

The QT60040 requires only a single external sampling capacitor (Cs) to operate. This capacitor should have good stability characteristics. It is possible but not optimal to use an X7R type capacitor, but for best stability a plastic type such as polyester or PPS film should be used. Increasing values will result in increased sensitivity, but too much sensitivity can also result in spurious operation. The optimal value of Cs will depend on the type of panel material, its thickness, and key geometry; experimentation is required to determine the proper value.

Typical suitable values of Cs range from 22nF to 220nF; 47nF is a good value to start from in most cases.

2.2 OPTION PINS

There are two option pins whose function is shown in Table 2-1.

OPT1 is used to set the rollover option. If this pin is connected to ground, the IC will only sense one key at a time. If OPT1 is left open or connected to Vdd, the IC can sense any two keys simultaneously and will suppress additional keys.

OPT2 is used to set the calibration time-out function. If OPT2 is connected to ground, keys will time out and recalibrate after 10 seconds of continuous detection on a key. If OPT2 is left open or connected to Vdd, keys will recalibrate after 60 seconds. In either

Table 2-1 Option Pin Functions

OPT1	Pin 3	Vdd	2 keys can be sensed
		Vss	1 key only can be sensed
OPT2	Pin 4	Vdd	60 seconds to recalibration
		Vss	10 seconds to recalibration

case the keys will continue to be functional after the time-out, to increased amounts of finger touch.

2.3 POWER SUPPLY

The IC uses the power supply rail as an internal reference voltage. If the power supply is shared with another electronic system, care should be taken to assure that the supply is free of digital spikes, sags, and surges which can adversely affect the circuit. The QT60040 will track slow changes in Vcc, but it can be adversely affected by rapid voltage steps and impulse noise on the supply rail.

The power supply can range from +2.5 to +5.5 volts, and should be regulated via a standard regulator such as a 78L05 type. In cases where low cost is an objective, it is possible to use double-zener regulation.

For proper operation a 100nF (0.1uF) ceramic bypass capacitor should be used between Vdd and Vss; the bypass cap should be placed very close to the device's power pins.

2.4 OUTPUTS

The device has four active-high outputs, one per sensing channel, which indicate touch. These outputs should be used for logic-level switching only and should not drive loads of more than 1mA. High loads can cause shifts in device Vdd and Vss rails which can lead to spurious operation.

2.5 ESD PROTECTION

In general the QT60040 will be protected from direct static discharge by the overlying panel. However, even with a panel, transients can still flow into the electrode via induction, or in extreme cases, via dielectric breakdown. Porous or thin materials may allow a spark to tunnel right through the panel material. Testing is required to reveal any problems. The QT60040 does have diode protection on its terminals which can absorb and protect the device from most induced discharges, up to 20mA; the usefulness of the internal clamping will depend on the dielectric properties, panel thickness, rise time of the ESD transients, and their duration.

The device pins can be further protected by inserting series resistance into the X and Y lines. The resistances chosen should not be so high as to interfere with the QT process. Every board layout is different and thus it is difficult to specify a suitable value, however, typical values will range from 1K ohms to 47K ohms. In serious cases additional low-capacitance high-conductance clamp diodes (e.g. BAV99) may be added to shunt ESD aside from the X and Y pins to the power and ground rails.

The QT60040's 'X' drive lines are always being driven at low impedance; they are never 3-state unless the circuit is just powering up or is powered down. This is a considerable advantage in dealing with ESD. The 4 output pins may also be vulnerable and should be resistor and/or diode protected if they are in danger of being subject to ESD.

Figure 3-1 E604 PCB Schematic

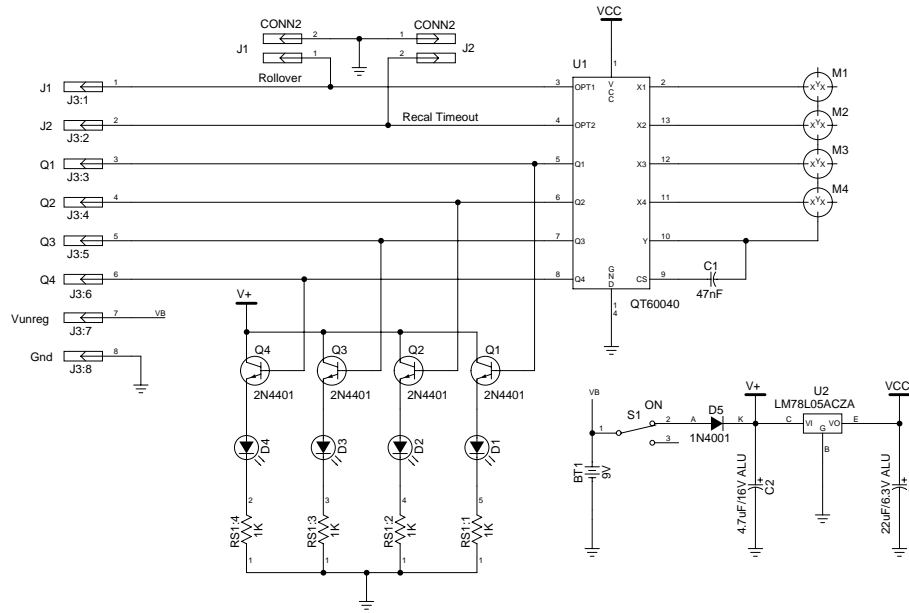
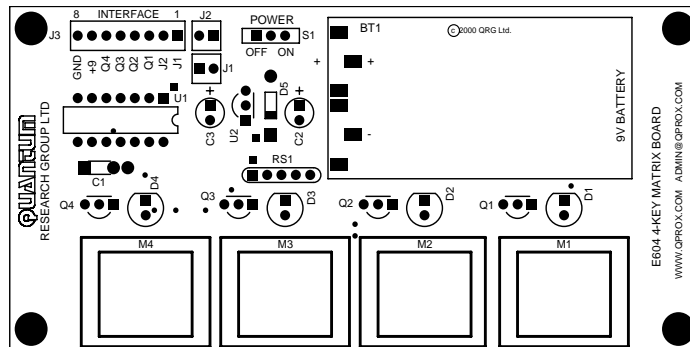
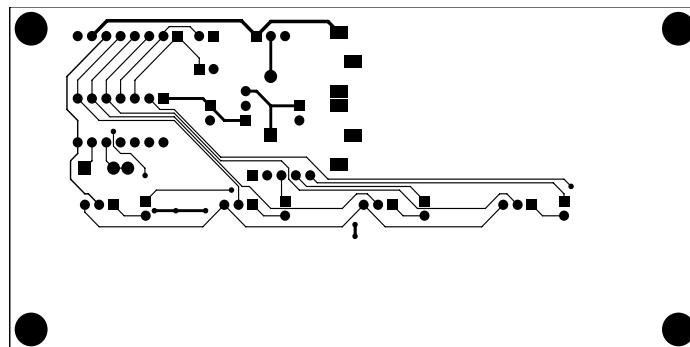

Figure 3-2 E604 PCB Layers

Silk Layer



Top Layer



Bottom Layer

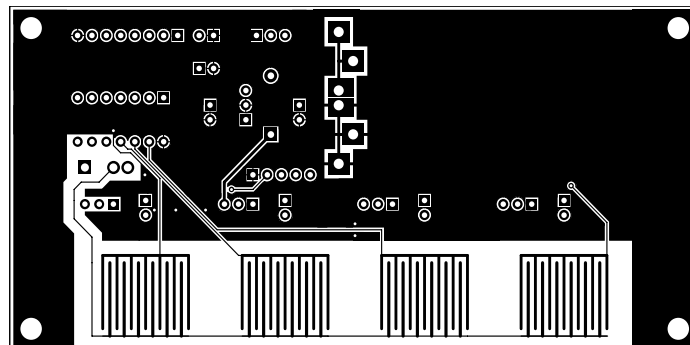

4.1 ABSOLUTE MAXIMUM SPECIFICATIONS

Operating temp.	as designated by suffix
Storage temp.	-55°C to +125°C
V _{DD}	-0.5 to +7.0V
Max continuous pin current, any control or drive pin.	±20mA
Short circuit duration to ground, any pin.	infinite
Short circuit duration to V _{DD} , any pin.	infinite
Voltage forced onto any pin.	-0.6V to (V _{DD} + 0.6) Volts

4.2 RECOMMENDED OPERATING CONDITIONS

V _{DD}	+2.5 to 5.25V
Supply ripple+noise.	10mV p-p max
C _s value.	22nF to 220nF
Output load.	±1mA

4.3 DC SPECIFICATIONS

V_{DD} = 5.0V, C_s = 47nF, T_A = recommended range, unless otherwise noted

Parameter	Description	Min	Typ	Max	Units	Notes
I _{DD5}	Supply current		0.65	1.5	mA	@ 5V
I _{DD3}	Supply current		0.4	0.6	mA	@ 3V
V _{DD-VSS}	Supply voltage range	2.5		5.5	V	
V _{IL}	Low input logic level			0.8	V	
V _{HL}	High input logic level	2.2			V	
V _{OL}	Low output voltage			0.6	V	4mA sink
V _{OH}	High output voltage	V _{DD} -0.7			V	1mA source
I _{IL}	Input leakage current			±1	µA	
A _R	Acquisition resolution			12	bits	

4.4 AC SPECIFICATIONS

V_{DD} = 5.0V, C_s = 47nF, T_A = recommended range, unless otherwise noted. Test circuit of Figure 3-1.

Parameter	Description	Min	Typ	Max	Units	Notes
T _r	Response time		85		ms	C _s and pad geometry dependent
S	Sensitivity		1		pF	
F _{qt}	Sample frequency		106		kHz	
T _{bs}	Burst spacing		5.3		ms	
T _d	Power-up delay to operate		0.5	1	secs	

4.5 SIGNAL PROCESSING

Parameter	Description	Min	Typ	Max	Units	Notes
DI	Detection integrator counts		4		counts	
Mo	Max On-Duration	10		60	s	±20%, option selectable
T	Threshold, D from reference		4		counts	counts of signal
H	Hysteresis		25		%	% of threshold
DRp	Drift rate, negative		1		counts / s	
DRn	Drift rate, positive		1	10	counts / s	
Rd	Recalibration duration		0.25	0.5	secs	

5.1 - ORDERING INFORMATION

PART	TEMP RANGE	PACKAGE	MARKING
QT60040-D	0 - 70C	PDIP-14	QT60040
QT60040-IS	-40 - 85C	SOIC-14	QT60040 - I

5.2 DUAL IN-LINE PACKAGE

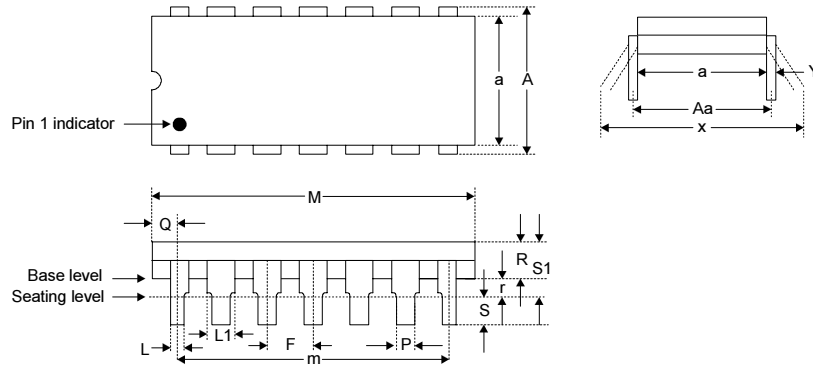

Package Type: Dual-in-Line						
SYMBOL	Millimeters			Inches		
	Min	Max	Notes	Min	Max	Notes
a	7.112	7.493		0.28	0.295	
A	7.874	8.382		0.31	0.33	
M	15.24	15.24		0.6	0.6	
m	18.8	19.3	BSC	0.74	0.76	BSC
Q	1.78	2.03		0.07	0.08	
P	0.36	0.56		0.014	0.022	
L1	1.14	1.78	Typical	0.045	0.070	Typical
F	2.54	2.54	BSC	0.100	0.100	BSC
R	2.92	3.68		0.115	0.145	
r	0.38	-		0.015	-	
S	3.18	3.43		0.125	0.135	
S1	3.56	4.32		0.14	0.17	
Aa	7.874	7.874		0.31	0.31	
x	8.128	9.906		0.32	0.39	
Y	0.20	0.38	Typical	0.008	0.015	Typical

5.3 SMALL OUTLINE PACKAGE

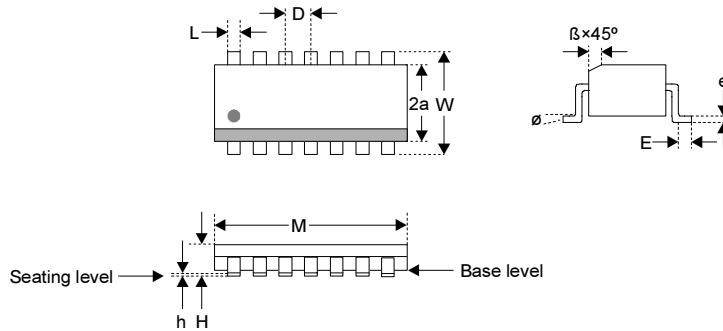

Package Type: 14 Pin SOIC						
SYMBOL	Millimeters			Inches		
	Min	Max	Notes	Min	Max	Notes
M	8.56	8.81		0.337	0.347	
W	5.79	6.20		0.228	0.244	
2a	3.81	3.99		0.150	0.157	
H	1.35	1.75		0.31	0.33	
h	0.10	0.25		0.004	0.010	
D	1.27	1.27	BSC	0.050	0.050	BSC
L	0.36	0.51		0.014	0.020	
E	0.41	1.27		0.016	0.050	
e	0.20	0.25		0.008	0.010	
B	0.25	0.51		0.014	0.020	
o	0	8		0	8	



Copyright © 2002 QRG Ltd. All rights reserved.
Patented and patents pending

Corporate Headquarters

1 Mitchell Point

Ensign Way, Hamble SO31 4RF

Great Britain

Tel: +44 (0)23 8056 5600 Fax: +44 (0)23 8045 3939

admin@qprox.com

www.qprox.com

North America

651 Holiday Drive Bldg. 5 / 300

Pittsburgh, PA 15220 USA

Tel: 412-391-7367 Fax: 412-291-1015

The specifications set out in this document are subject to change without notice. All products sold and services supplied by QRG are subject to our Terms and Conditions of sale and supply of services which are available online at www.qprox.com and are supplied with every order acknowledgement. QProx, QTouch, QMatrix, QLevel, and QSlide are trademarks of QRG. QRG products are not suitable for medical (including life-saving equipment), safety or mission critical applications or other similar purposes. Except as expressly set out in QRG's Terms and Conditions, no licenses to patents or other intellectual property of QRG (express or implied) are granted by QRG in connection with the sale of QRG products or provision of QRG services. QRG will not be liable for customer product design and customers are entirely responsible for their products and applications which incorporate QRG's products.