

阅读申明

- 1.本站收集的数据手册和产品资料都来自互联网，版权归原作者所有。如读者和版权方有任何异议请及时告之，我们将妥善解决。
- 2.本站提供的中文数据手册是英文数据手册的中文翻译，其目的是协助用户阅读，该译文无法自动跟随原稿更新，同时也可能存在翻译上的不当。建议读者以英文原稿为参考以便获得更精准的信息。
- 3.本站提供的产品资料，来自厂商的技术支持或者使用者的心得体会等，其内容可能存在描述上的差异，建议读者做出适当判断。
- 4.如需与我们联系，请发邮件到marketing@iczoom.com，主题请标有“数据手册”字样。

Read Statement

1. The datasheets and other product information on the site are all from network reference or other public materials, and the copyright belongs to the original author and original published source. If readers and copyright owners have any objections, please contact us and we will deal with it in a timely manner.
2. The Chinese datasheets provided on the website is a Chinese translation of the English datasheets. Its purpose is for reader's learning exchange only and do not involve commercial purposes. The translation cannot be automatically updated with the original manuscript, and there may also be improper translations. Readers are advised to use the English manuscript as a reference for more accurate information.
3. All product information provided on the website refer to solutions from manufacturers' technical support or users the contents may have differences in description, and readers are advised to take the original article as the standard.
4. If you have any questions, please contact us at marketing@iczoom.com and mark the subject with "Datasheets" .

- Four independent QT touch circuits
- Individual outputs per channel - active high
- Projects prox fields through any dielectric
- Sensitivity easily adjusted on a per-channel basis
- 100% autocal for life - no adjustments required
- 3.9V ~ 5.5V single supply operation
- 10s, 60s, infinite auto-recal timeout (strap options)
- Sync pin for line sync to suppress noise
- Spread spectrum operation
- Pin options for auto recalibration timings
- Extremely low cost per key
- 20-SSOP package
- Lead-free version available

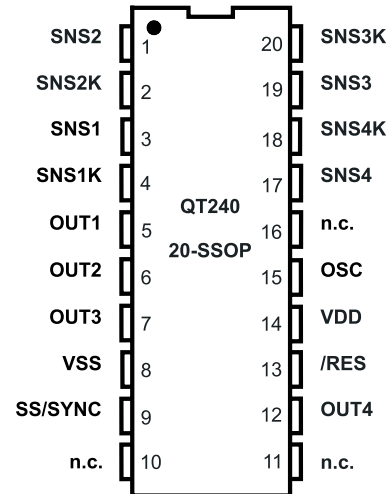

APPLICATIONS

- ◆ PC Peripherals
- ◆ Backlighted buttons
- ◆ Appliance controls
- ◆ Security systems
- ◆ Access systems
- ◆ Pointing devices
- ◆ Instrument panels
- ◆ Gaming machines

The QT240 charge-transfer (“QT”) QTouch IC is a self-contained digital sensor IC capable of detecting near-proximity or touch on 4 electrodes. It allows electrodes to project independent sense fields through any dielectric like glass, plastic, stone, ceramic, and wood. It can also turn metal-bearing objects into intrinsic sensors, making them responsive to proximity or touch. This capability coupled with its continuous self-calibration feature can lead to entirely new product concepts, adding high value to product designs.

Each of the channels operates independently of the others, and each can be tuned for a unique sensitivity level by simply changing its sample capacitor value. Two speeds are supported, one of which consumes only 90µA of typical current at 4V. Unique among capacitance sensors, the device incorporates spread spectrum modulation for unsurpassed EMC compliance.

The devices are designed specifically for human interfaces, like control panels, appliances, gaming devices, lighting controls, or anywhere a mechanical switch or button may be found; they may also be used for some material sensing and control applications.

These devices feature a SYNC pin which allows for synchronization with additional similar parts and/or to an external source to suppress interference. This pin doubles as a drive pin for spread-spectrum modulation. Option pins are provided which allow different timing and feature settings.

The RISC core of these devices use signal processing techniques pioneered by Quantum which are designed to survive numerous real-world challenges, such as ‘stuck sensor’ conditions, component ageing, moisture films, and signal drift.

By using the charge transfer principle, these devices deliver a level of performance clearly superior to older technologies yet are highly cost-effective.

AVAILABLE OPTIONS

T _A	SSOP-20	Lead-Free
-40°C to +85°C	QT240-ISS	No
-40°C to +85°C	QT240-ISS-G	Yes

1 - OVERVIEW

QT240 devices are burst mode digital charge-transfer (QT) sensor ICs designed specifically for touch controls; they include all hardware and signal processing functions necessary to provide stable sensing under a wide variety of conditions. Only a single low cost capacitor per channel is required for operation.

Figures 1-1 and 1-2 show basic circuits for these devices. See Table 1-1 for device pin listings.

The devices employ bursts of charge-transfer cycles to acquire signals. Burst mode permits low power operation, dramatically reduces RF emissions, lowers susceptibility to RF fields, and yet permits excellent speed. Internally, signals are digitally processed to reject impulse noise using a 'consensus' filter that requires six consecutive confirmations of detection.

The QT switches and charge measurement hardware functions are all internal to the device. A single-slope switched capacitor ADC includes the QT charge and transfer switches in a configuration that provides direct ADC conversion; an external Cs capacitor accumulates the charge from sense-plate Cx, which is then measured.

Larger values of Cx cause the charge transferred into Cs to rise more rapidly, reducing available resolution; as a minimum resolution is required for proper operation, this can result in dramatically reduced gain. Larger values of Cs reduce the rise of differential voltage across it, increasing available resolution by permitting longer QT bursts. The value of Cs can thus be increased to allow larger values of Cx to be tolerated. The IC is responsive to both Cx and Cs, and changes in either can result in substantial changes in sensor gain.

Unused channels: If a channel is not used, a dummy sense capacitor (nominal value: 1nF) of any type plus a 2.2K series resistor must be connected between unused SNS pin pairs ensure correct operation.

1.1 OPERATING MODES

The QT240 features spread-spectrum acquisition capability, external synchronization of acquire bursts, and fast and slow acquisition modes. These modes are enabled via high-value resistors connected to the SNS pins to ground or Vdd. These resistors are required in every circuit.

There are two basic modes as shown in Figures 1-1 and 1-2.

Low-power Sync mode: In this mode the device operates with about a 100ms response time and very low current (about 90µA average at 4.0V). This mode allows the device to be synchronized to an external clock source, which can be used to either suppress external interference (such as from 50/60Hz wiring) or to decrease response time (which will also increase power consumption). Spread-spectrum operation is not directly supported in this mode. Sync usage is optional; the Sync pin should simply be grounded if unused.

Fast, Spread-Spectrum mode: In this mode the device operates with ~40ms response times but higher current drain (~1.5mA @ 4.0V). This mode also supports spread-spectrum operation via a few

TABLE 1-1 PIN LISTING - QT240-ISS

Pin	Name	Description
1	SNS2	Sense pin (to Rs2 + Cs2)
2	SNS2K	Sense pin (to Cs2, electrode)
3	SNS1	Sense pin (to Rs1 + Cs1)
4	SNS1K	Sense pin (to Cs1, electrode); speed option
5	OUT1	Output, key 1
6	OUT2	Output, key 2
7	OUT3	Output, key 3
8	VSS	Ground
9	SYNC/SS	Sync in and/or spread spectrum drive
10	n.c.	Unbonded internally
11	n.c.	Unbonded internally
12	OUT4	Output, key 4
13	/RES	Reset pin, active low. Can usually tie to Vdd.
14	VDD	Power: +4.0 to +5V locally regulated
15	OSC	Oscillator bias in
16	VSS	Ground or no connect
17	SNS4	Sense pin (to Rs4 + Cs4)
18	SNS4K	Sense pin (to Cs4, electrode); OPT2
19	SNS3	Sense pin (to Rs3 + Cs3)
20	SNS3K	Sense pin (to Cs3, electrode); OPT1

optional passive parts (if desired). Sync operation is not supported in this mode.

1.2 ELECTRODE DRIVE; WIRING

The QT240 has four completely independent sensing channels. The conversion process treats Cs on each channel as a floating transfer capacitor; as a direct result, sense electrodes can be connected to either SNS pin and the sensitivity and basic function will be the same; however electrodes should be connected to SNSnK lines to reduce EMI susceptibility.

The PCB traces, wiring, and any components associated with or in contact with either SNS pin will become touch sensitive and should be treated with caution to limit the touch area to the desired location.

FIGURE 1-1 LOW POWER, SYNCHRONIZED CIRCUIT

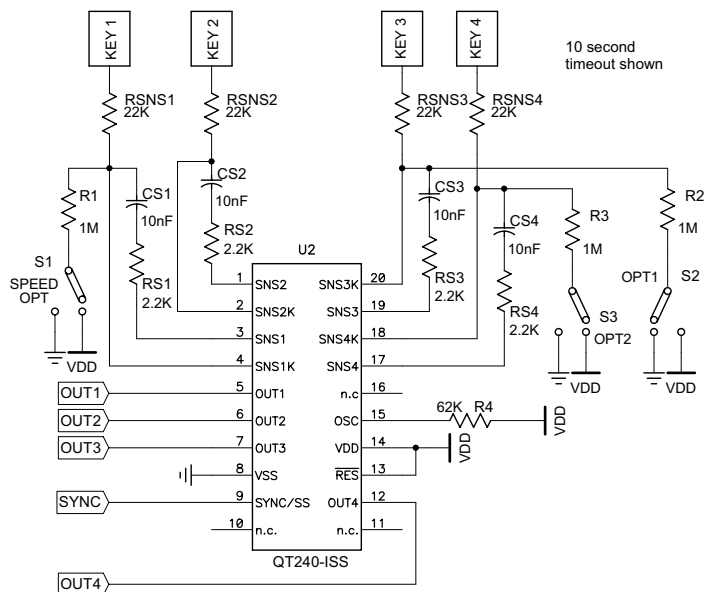
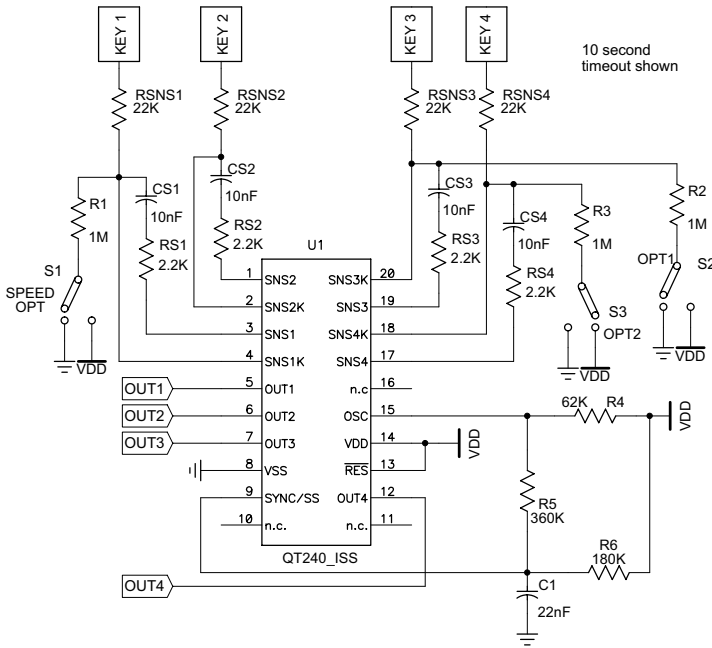

FIGURE 1-2 FAST, SPREAD-SPECTRUM CIRCUIT



Multiple touch electrodes connected to any SNSnK can be used, for example to create control surfaces on both sides of an object.

It is important to limit the amount of stray capacitance on the SNS terminals, for example by minimizing trace lengths and widths to allow for higher gain without requiring higher values of Cs. Under heavy delta-Cx loading of one key, cross coupling to another key's trace can cause the other key to trigger. Therefore, electrode traces from adjacent keys should not be run close to each other over long runs in order to minimize cross-coupling if large values of delta-Cx are expected, for example when an electrode is directly touched. This is not a problem when the electrodes are working through a plastic panel with normal touch sensitivity.

1.3 SENSITIVITY

Sensitivity can be altered to suit various applications and situations on a channel-by-channel basis. The easiest and most direct way to impact sensitivity is to alter the value of each Cs; more Cs yields higher sensitivity. Each channel has its own Cs value and can therefore be independently adjusted.

1.3.1 ALTERNATIVE WAYS TO INCREASE SENSITIVITY

Sensitivity can also be increased by using bigger electrode areas, reducing panel thickness, or using a panel material with a higher dielectric constant.

1.3.2 DECREASING SENSITIVITY

In some cases the circuit may be too sensitive. Gain can be lowered further by a number of strategies: a) making the electrode smaller, b) making the electrode into a sparse mesh using a high space-to-conductor ratio, or c) by decreasing the Cs capacitors.

1.3.3 KEY BALANCE

A number of factors can cause sensitivity imbalances. Notably, SNS wiring to electrodes can have differing stray amounts of capacitance to ground. Increasing load capacitance will cause a decrease in gain. Key size differences, and proximity to other metal surfaces can also impact gain.

The four keys may thus require 'balancing' to achieve similar sensitivity levels. This can be best accomplished by trimming the values of the four Cs capacitors to achieve equilibrium. The four Rs resistors have no effect on sensitivity and should not be altered. Load capacitances can also be added to overly sensitive channels to ground, to reduce their gains. These should be on the order of a few picofarads.

2 - QT240 SPECIFICS

2.1 SIGNAL PROCESSING

These devices process all signals using 16 bit math, using a number of algorithms pioneered by Quantum. These algorithms are specifically designed to provide for high survivability in the face of adverse environmental changes.

2.1.1 DRIFT COMPENSATION

Signal drift can occur because of changes in Cx, Cs, and Vdd over time. If a low grade Cs capacitor is chosen, the signal can drift greatly with temperature. If keys are subject to extremes of temperature or humidity, the signal can also drift. It is crucial that drift be compensated, else false detections, non-detections, and sensitivity shifts will follow.

Drift compensation (Figure 2-1) is a method that makes the reference level track the raw signal at a slow rate, only while no detection is in effect. The rate of reference adjustment

must be performed slowly else legitimate detections can also be ignored. The IC drift compensates each channel independently using a slew-rate limited change to the reference level; the threshold and hysteresis values are slaved to this reference.

Once an object is sensed, the drift compensation mechanism ceases since the signal is legitimately high, and therefore should not cause the reference level to change.

The signal drift compensation is 'asymmetric'; the reference level drift-compensates in one direction faster than it does in the other. Specifically, it compensates faster for decreasing signals than for increasing signals. Increasing signals should not be

Figure 2-1 Drift Compensation

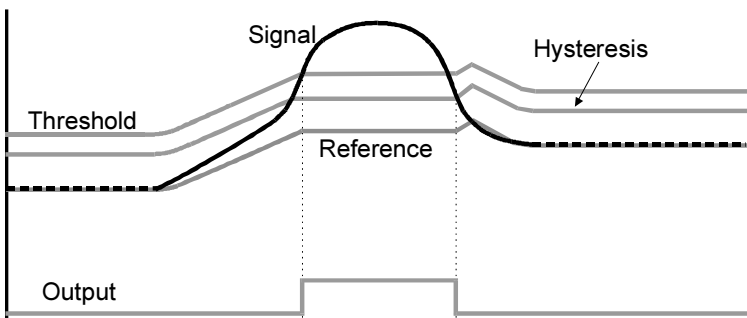

compensated for quickly, since an approaching finger could be compensated for partially or entirely before even approaching the sense electrode. However, an obstruction over the sense pad, for which the sensor has already made full allowance for, could suddenly be removed leaving the sensor with an artificially elevated reference level and thus become insensitive to touch. In this latter case, the sensor will compensate for the object's removal very quickly, usually in only a few seconds.

With large values of C_s and small values of C_x , drift compensation will appear to operate more slowly than with the converse.

Drift Compensation in Slow Mode: Drift compensation rates in Slow mode are preserved if there is no Sync signal, and the rates are derived from the ~90ms Sleep interval. However if there is a Sync signal, then drift compensation rates are derived from an assumption that the Sync periodicity is ~18ms (which corresponds to 55.5Hz). Thus, drift compensation timings in Sync mode are correct for an ~18ms Sync period but different (slower or faster) for other Sync periods. For example a Sync period of 36ms would halve the expected drift compensation rates.

2.1.2 THRESHOLD LEVEL

The internal threshold level is fixed at 12 counts for all four channels. The hysteresis is fixed at 2 counts (17%).

2.1.3 MAX ON-DURATION

If a sufficiently large object contacts a key for a prolonged duration, the signal will trigger a detection output preventing further normal operation. To cure such 'stuck key' conditions, the sensor includes a timer on each channel to monitor detection duration. If a detection exceeds the maximum timer setting, the timer causes the sensor to perform a full recalibration (if not set for infinite). This is known as the Max On-Duration feature.

After the Max On-Duration interval, the sensor channel will once again function normally, even if partially or fully obstructed, to the best of its ability given electrode conditions. There are three timeout durations available via strap option: 10s, 60s, and infinite (Table 2-2).

Max On-Duration works independently per channel; a timeout on one channel has no effect on another channel. Note also that the timings in Table 2-2 are dependent on the oscillator frequency in fast mode. Doubling the recommended frequency will halve the timeouts. This is not true in Slow mode.

Infinite timeout is useful in applications where a prolonged detection can occur and where the output must reflect the detection no matter how long. In infinite timeout mode, the designer should take care to be sure that drift in C_s , C_x , and V_{dd} do not cause the device to 'stick on' inadvertently even when the target object is removed from the sense field.

Timeouts are approximate and can vary substantially over V_{dd} and temperature, and should not be relied upon for critical functions. Timeouts are also dependent on operating frequency in Fast mode.

Max On-Duration in Slow Mode: When Sync mode is used in Slow mode, the Max On-Duration timings are derived from the Sync period. The device assumes the Sync periodicity is 18ms (midway between 50Hz and 60Hz sync timings). Thus, Max On-Duration timings in Sync mode are correct for an

18ms Sync period but different (shorter or longer) for other Sync periods. For example a Sync period of 36ms would double all expected Max On-Duration timings.

2.1.4 DETECTION INTEGRATOR

It is desirable to suppress false detections due to electrical noise or from quick brushes with an object. To this end, these devices incorporate a per-key 'Detection Integrator' counter that increments with each signal detection exceeding the signal threshold (Figure 2-1) until a limit count is reached, after which an Out pin becomes active. If a 'no detect' is sensed even once prior to the limit, this counter is reset to zero and no detect output is generated. The required limit count is 6.

The Detection Integrator can also be viewed as a 'consensus' vote requiring a detection in successive samples to trigger an active output.

In slow mode, the detect integrator forces the device to operate faster to confirm a detection. The six successive acquisitions required to affirm a detection are done without benefit of a low power sleep mode between bursts.

2.1.5 FORCED SENSOR RECALIBRATION

Pin 13 is a Reset pin, active-low, which in cases where power is clean can be simply tied to V_{dd} . On power-up, the device will automatically recalibrate all channels of sensing.

Pin 13 can also be controlled by logic or a microcontroller to force the chip to recalibrate, by toggling it low for 10 μ s or more, then raising it high again.

2.1.6 FAST POSITIVE RECALIBRATION

If the sensed capacitance becomes lower by 5 counts than the reference level for 2 seconds, the sensor will consider this to be an error condition and will force a recalibration on the affected channel.

2.2 OPTIONS

These devices are designed for maximum flexibility and can accommodate most popular sensing requirements via option pins.

The option pins are read on power-up and about once every 10 seconds while the device is not detecting touch on any channel. Options are set using high value resistors connected to certain SNS pins, to either V_{dd} or V_{ss} . These options are read 25 times over 250 μ s to ensure that they are not influenced by noise pulses. All 25 samples must agree. However, large values of C_x on the SNS wires can load down the pins to the point where the 1M pullup resistors cannot pull high fast enough, and the pins are read erroneously as a result. C_x should be below 50pF to prevent errors; this value can be read with a conventional capacitance meter with the QT240 removed.

The option setting resistors are mandatory and cannot be deleted. They must be strapped to either V_{dd} or V_{ss} .

Speed option (Strap S1): This jumper selects whether the device acts in a slower, low power mode with a response time of approximately 100ms, or in a fast mode with a response time of 40ms typical. Fast mode consumes substantially more power than the slow mode, but also enables the use of spread-spectrum detection. Only slow mode supports the use of external Sync (Section 2.3).

TABLE 2-1 S1 SPEED / SYNC OPTIONS - SNS1K PIN 4

Fast / Spread Spectrum	Vss
Slow / Sync	Vdd

TABLE 2-2 OPT OPTIONS

	S2 SNS3K pin 20	S3 SNS4K pin 18	Max On-Duration
DC Out	Vss	Vdd	10s
DC Out	Vdd	Vss	60s
Toggle	Vdd	Vdd	10s
DC Out	Vss	Vss	infinite

Timings assume 100 kHz operation

Response time can also be modified by changing the oscillator frequency (Section 3.3).

Recalibration / toggle select (S2, S3): See Table 2-2. There are 3 recalibration timing options ('Max On-Duration'; see Section 2.1.3) and one toggle mode option. The recalibration options control how long it takes for a continuous detection to trigger a recalibration on a key. When such an event occurs, only the 'stuck' key is recalibrated. S2 / S3 should be connected as shown in Table 2-2 to achieve the desired Max On-Duration of either 10s, 60s, or infinite.

Toggle option: One option is toggle mode, which allows all four keys to behave with flip-flop action. In this mode, each key's corresponding OUT pin will toggle High / Low with successive touches on the key. The underlying Max On-Duration is 10s in this mode. If a timeout occurs in Toggle mode, the toggle state is not affected. Toggle state flips only when the corresponding Out pin goes High.

This is useful for controlling power loads, for example in kitchen appliances, power tools, light switches, etc. or wherever a 'touch-on / touch-off' effect is required.

2.3 SYNCHRONIZATION

Sync capability is only present in Slow mode (Section 2.2). If SYNC is not desired, SYNC/SS should be connected to Vss.

Adjacent capacitive sensors that operate independently can cross-interfere with each other in ways that will create sensitivity shifts and spurious detections. Since Quantum's QT devices operate in burst mode, the opportunity exists to solve this problem by time-sequencing sensing channels so that physically adjacent keys do not sense at the same time. Within the QT240 the four channels operate synchronously, so it is not possible for these channels to cross interfere. However 2 or more adjacent chips will cross-interfere if they are not synchronized to each other. The same is true of the effects of unsynchronized external noise sources.

External noise sources can also be heavily suppressed by synchronizing the QT240 to the noise source period. External noise creates an 'aliasing' or 'beat' frequency effect between the sampling rate of the QT part and the external noise frequency. This shows up as a random noise component on the internal signals, which in turn can lead to false activation.

Mains frequency is one common source of interference. A simple AC zero-crossing detector feeding the SYNC pin is enough to suppress this kind of periodic noise. Multiple devices tied to SYNC can be synchronized to the mains frequency in this fashion.

If two physically adjacent devices are to be synchronized to each other, they should be connected via the SYNC pin to a clock source that is slower than the burst rate of either device. For example, a 50Hz clock can synchronize two QT240's running with burst spacings of up to 10ms each. The two QT240's should be synchronized on opposite phases of the clock source, ie the clock source should feed one part and its inverted phase, the other part.

A sync pulse on SYNC/SS in slow mode acts to break the QT240 out of its sleep state between bursts, and to do another burst. The device will then go back to sleep again and await a new SYNC pulse. If a Sync pulse does not arrive within about 90ms, it will wake again and run normally.

External sync pulses can be used to accelerate response time (at the expense of power) in Slow mode. Sync pulses running at 25Hz for example will improve response time by a factor of 2. Sync cannot be used to slow down the device.

Sync Mode Effects on Timings: In the absence of a Sync signal, the Max On-Duration timings and drift compensation rates in Slow mode are nominally correct. It should be understood that the Max On-Duration timings and drift compensation rates are slaved to the burst interval in Slow mode, and that changing the burst interval will have direct effects on these parameters.

Since the most common use of Sync is to synchronize the device to Mains frequency (50 or 60Hz) the device makes an assumption that the presence of a Sync signal is at 55Hz, and the timings are made to be correct at this frequency.

Should the Sync pulses vary from this frequency, the Max On-Duration timings and drift compensation rates will vary proportionately. Thus, if the Sync pulses are 25Hz, the 10-second Max On-Duration timing will become $10 \times 55 / 25 = 22$ seconds nominal. Only at Sync=55Hz with the 10s timeout be 10s (the same as if there were no Sync signal, or the device was in Fast mode).

3 - CIRCUIT GUIDELINES

3.1 CS SAMPLE CAPACITOR

Charge sampler caps Cs can be virtually any plastic film or low to medium-K ceramic capacitor. The 'normal' Cs range is 4.7nF to 47nF depending on the sensitivity required; larger values of Cs require higher stability to ensure reliable sensing. Acceptable capacitor types for most uses include plastic film (especially PPS film and polypropylene film) and X7R ceramic. Lower grades than X7R are not advised; higher-K ceramics have nonlinear dielectrics which induce instabilities.

3.2 POWER SUPPLY, PCB LAYOUT

The power supply can range from 3.9 to 5.5 volts. If this fluctuates slowly with temperature, the device will track and compensate for these changes automatically with only minor changes in sensitivity. If the supply voltage drifts or shift quickly, the drift compensation mechanism will not be able to keep up, causing sensitivity anomalies or false detections.

The QT240 will track slow changes in Vdd, but can be seriously affected by rapid voltage steps.

If the supply is shared with another electronic system, care should be taken to assure that the supply is free of digital spikes, sags, and surges which can cause adverse effects.

The supply is best locally regulated using almost any 3-terminal LDO device from 4.0V to 5V.

For proper operation a 0.1µF or greater bypass capacitor must be used between Vdd and Vss; the bypass cap should be placed very close to the device Vss and Vdd pins.

The PCB should if possible include a copper pour under and around the IC, but not extensively under the SNS lines.

3.3 OSCILLATOR; SPREAD SPECTRUM

The oscillator is an internal type using an external current bias source. Normal operation occurs at ~100 kHz +/-20% with R=62K at Vdd = 4.0V.

In Fast mode the oscillator can be spread-spectrum modulated with a simple external RC network to avoid dwelling on any one frequency. The circuit works by current modulating the oscillator bias to provide a chirp modulation within each burst. This helps dramatically with both RF emissions and susceptibility. The circuit for this is shown in Figure 1-2. The SYNC/SS pin outputs a rectangular pulse with a period of one burst. At the end of the burst, SYNC/SS clamps to ground. This forms a sawtooth modulation waveform to create the frequency chirp modulation (Figure 3-1).

The detection integrator (DI) filters out false detections caused by interference on up to any 6 of these acquisitions. The DI is a consensus filter that throws out a pending detection if even one of the 6 samples does not confirm a detection. As a result of this feature, it is extremely difficult for an external signal to interfere with the device.

The typical modulation band of this circuit is +/-7% around the center frequency.

The oscillator frequency can be measured by observing the acquisition pulses on any sense channel with an oscilloscope. The first two positive pulses in each burst will be exactly 10µs from rising edge to rising edge (100kHz) if the oscillator is set correctly (no spread spectrum). Some subsequent pulse pairs will have wider spacings; this is normal.

If desired the response time of the device in Fast mode can be modified by altering the oscillator frequency. The device can be set to any center frequency from 20kHz to 150kHz by simply altering the value of the bias resistor. Lower values of R will speed up the device. Higher resistor values will slow down the device and reduce power consumption.

Slow mode relies on an internal RC timer which cannot be adjusted via the bias resistor. During intervals between bursts in Slow mode, the 100kHz oscillator is disabled.

Spread Spectrum in Slow Mode: The QT240 does not support spread spectrum in Slow mode directly via the SYNC/SS pin. However, the designer can still implement spread

spectrum by modulating the oscillator through a resistor to OSC with a triangle or sawtooth wave.

The modulation signal should be exactly synchronous with each burst, so that the resulting acquired signal is modulated in the same way. If this rule is not followed, the signals will contain modulation noise and false detections may occur.

3.4 UNUSED CHANNELS

Unused SNS pins should not be left open. They should have a small value non-critical dummy Cs capacitor plus a 2.2K series-R connected to their SNS pins to allow the internal circuit to continue to function properly. A nominal value of 1nF (1,000pF) X7R ceramic will suffice.

Unused channels should not have sense traces or electrodes connected to them except for the required option resistors, which must always be installed and connected to Vdd or Vss.

3.5 ESD PROTECTION

Normally, only a series resistor is required for ESD suppression. A 22K Rsns resistor in series with the sense trace is sufficient in most cases. The dielectric panel (glass or plastic) usually provides a high degree of isolation to prevent ESD discharge from reaching the circuit. Rsns should be placed close to the chip.

If the Cx load is high, Rsns can prevent total charge and transfer and as a result gain can deteriorate. If a reduction in Rsns increases gain noticeably, the lower value should be used. Conversely, increasing the Rsns can result in added ESD and EMC benefits provided that the increase does not decrease sensitivity.

3.6 CROSSTALK PRECAUTIONS

Adjacent sense traces might require intervening ground traces in order to reduce capacitive cross bleed if high sensitivity is required or high values of delta-Cx are anticipated (for example, from direct human touch to an electrode connection). In normal touch applications behind plastic panels this is almost never a problem regardless of how the electrodes are wired.

Figure 3-1 Spread-Spectrum Waveforms

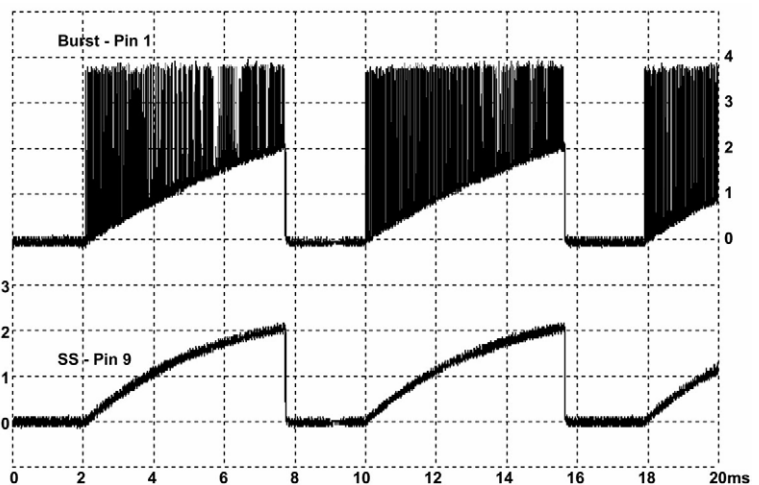

Higher values of R_{sns} will make crosstalk problems worse; try to keep R_{sns} to 22K or less if possible.

In general try to keep the QT240 close to the electrodes and reduce the adjacency of the sense wiring to ground planes

and other signal traces; this will reduce the Cx load, reduce interference effects, and increase signal gain.

The one and only valid reason to run ground near SNS traces is to provide crosstalk isolation between traces, and then only on an as-needed basis.

4.1 ABSOLUTE MAXIMUM SPECIFICATIONS

Operating temp.	as designated by suffix
Storage temp.	-55°C to +105°C
V _{DD}	-0.3 to +5.5V
Max continuous pin current, any control or drive pin.	±20mA
Short circuit duration to ground, any pin.	infinite
Short circuit duration to V _{DD} , any pin.	infinite
Voltage forced onto any pin.	-0.3V to (V _{DD} + 0.3) Volts

4.2 RECOMMENDED OPERATING CONDITIONS

V _{DD}	+3.9 to +5.0V
Operating temperature range, 4.0V - 5.5V.	-40 - +85C
Operating frequency, 4.0V - 5.5V.	100 kHz
Short-term supply ripple+noise.	±5mV
Long-term supply stability.	±100mV
C _s (reference capacitors) value.	4.7nF to 47nF
C _x (SNS load capacitance) maximum value.	50pF

4.3 AC SPECIFICATIONS V_{DD} = 4.0, T_a = recommended, C_x = 10pF, C_s = 10nF, R_{osc} = 62K ohms

Parameter	Description	Min	Typ	Max	Units	Notes
T _{RC}	Recalibration time from cold start or hard reset		180 280		ms ms	Fast mode Slow mode
T _{PC}	Pulse duration		2		µs	Either speed mode
T _{PT}	Clamp duration		8		µs	Either speed mode
T _{AC}	Burst duration, all channels		4		ms	Either speed mode
N _{BL}	Burst length, each channel		250		counts	Either speed mode
T _R	Response time to output		40 110		ms ms	Fast mode Slow mode
F _{OSC}	Acquisition center frequency	80	100	120	kHz	Either speed mode
F _{SSD}	Spread spectrum freq deviation		+/-7		%	% of Fosc; fast mode only; Circuit of Figure 1-2
T _{SS}	Spread spectrum drive interval		6		bursts	Fast mode only

4.4 DC SPECIFICATIONS

V_{DD} = 4.0V, C_x = 10pF, C_s = 10nF, F_{osc} = 100kHz, T_a = recommended range, unless otherwise noted

Parameter	Description	Min	Typ	Max	Units	Notes
I _{DD}	Supply current		1.5 90		mA µA	Fast mode Slow mode, no Sync
V _{DDS}	Supply turn-on slope	100			V/s	Req'd for startup, w/o reset circuit
V _{IL}	Low input logic level			0.7	V	SYNC, RST
V _{HL}	High input logic level	2			V	SYNC, RST
V _{OL}	Low output voltage			0.6	V	OUTn, 4mA sink
V _{OH}	High output voltage	V _{DD} -0.7			V	OUTn, 1mA source
I _{IL}	Input leakage current			±1	µA	OPT1, OPT2, OPT3
A _R	Acquisition resolution		9		bits	

4.5 SIGNAL PROCESSING

V_{dd} = 4.0V, C_x = 10pF, C_s = 10nF, F_{osc} = 100kHz, T_a = recommended range, unless otherwise noted

Description	Value	Units	Notes
Threshold differential (positive)	12	counts	From signal reference
Hysteresis	2	counts	From threshold
Fast negative threshold differential	5	counts	
Consensus filter length (Detection integrator)	6	samples	
Positive drift compensation rate	1,000	ms/level	Nominal timing dependent on F _{osc} , Sync
Negative drift compensation rate	250	ms/level	Nominal timing dependent on F _{osc} , Sync
Fast negative recalibration timer duration	2	secs	Nominal timing dependent on F _{osc} , Sync
Post-detection recalibration timer duration	10, 60, infinite	secs	Option pin selected; Nominal timings; dependent on F _{osc} , Sync

5 - PACKAGE OUTLINE

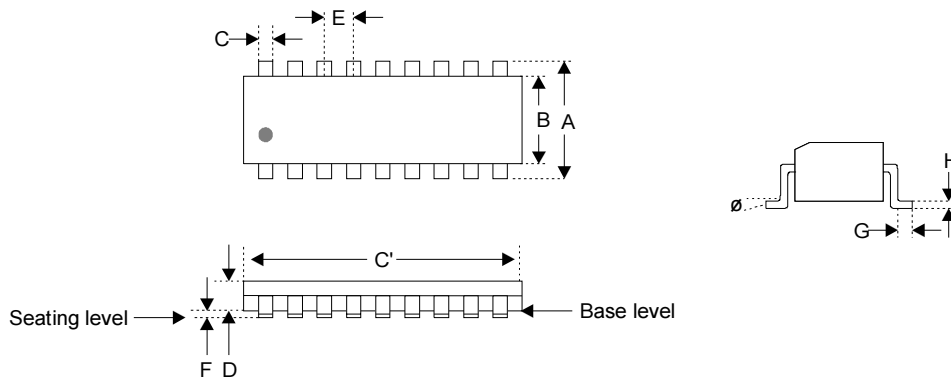

209 mil 20-pin SSOP Dimensions						
SYMBOL	Inches (mils)			Metric (mm)		
	Min	Typ	Max	Min	Typ	Max
A	291.0		323.0	7.39		8.20
B	196.0		220.0	4.98		5.59
C	9.0		15.0	0.23		0.38
C'	271.0		295.0	6.88		7.49
D	65.0		73.0	1.65		1.85
E	-	25.0	-	-	0.635	-
F	4.0		10.0	0.10		0.25
G	26.0		34.0	0.66		0.86
H	4.0		8.0	0.10		0.20
ϕ	0°		8°	0°		8°

6 - ORDERING INFORMATION

PART	TEMP RANGE	PACKAGE	MARKING	LEAD-FREE
QT240-ISS	-40 - 85C	SSOP-20	QT240-I	No
QT240-ISS-G	-40 - 85C	SSOP-20	QT240-IG	Yes



Copyright © 2004 QRG Ltd. All rights reserved.
Patented and patents pending

Corporate Headquarters

1 Mitchell Point
Ensign Way, Hamble SO31 4RF
Great Britain

Tel: +44 (0)23 8056 5600 Fax: +44 (0)23 8045 3939

admin@qprox.com

www.qprox.com

North America

651 Holiday Drive Bldg. 5 / 300
Pittsburgh, PA 15220 USA
Tel: 412-391-7367 Fax: 412-291-1015

The specifications set out in this document are subject to change without notice. All products sold and services supplied by QRG are subject to our Terms and Conditions of sale and supply of services which are available online at www.qprox.com and are supplied with every order acknowledgement. QProx, QTouch, QMatrix, QLevel, QView, QWheel, and QSlide are trademarks of QRG. QRG products are not suitable for medical (including life-saving equipment), safety or mission critical applications or other similar purposes. Except as expressly set out in QRG's Terms and Conditions, no licenses to patents or other intellectual property of QRG (express or implied) are granted by QRG in connection with the sale of QRG products or provision of QRG services. QRG will not be liable for customer product design and customers are entirely responsible for their products and applications which incorporate QRG's products.