

阅读申明

- 1.本站收集的数据手册和产品资料都来自互联网，版权归原作者所有。如读者和版权方有任何异议请及时告之，我们将妥善解决。
- 2.本站提供的中文数据手册是英文数据手册的中文翻译，其目的是协助用户阅读，该译文无法自动跟随原稿更新，同时也可能存在翻译上的不当。建议读者以英文原稿为参考以便获得更精准的信息。
- 3.本站提供的产品资料，来自厂商的技术支持或者使用者的心得体会等，其内容可能存在描述上的差异，建议读者做出适当判断。
- 4.如需与我们联系，请发邮件到marketing@iczoom.com，主题请标有“数据手册”字样。

Read Statement

1. The datasheets and other product information on the site are all from network reference or other public materials, and the copyright belongs to the original author and original published source. If readers and copyright owners have any objections, please contact us and we will deal with it in a timely manner.
2. The Chinese datasheets provided on the website is a Chinese translation of the English datasheets. Its purpose is for reader's learning exchange only and do not involve commercial purposes. The translation cannot be automatically updated with the original manuscript, and there may also be improper translations. Readers are advised to use the English manuscript as a reference for more accurate information.
3. All product information provided on the website refer to solutions from manufacturers' technical support or users the contents may have differences in description, and readers are advised to take the original article as the standard.
4. If you have any questions, please contact us at marketing@iczoom.com and mark the subject with "Datasheets" .

AEDT-981x

High Temperature 115°C, High Resolution,
Three Channels Optical Incremental Encoder Modules



Data Sheet

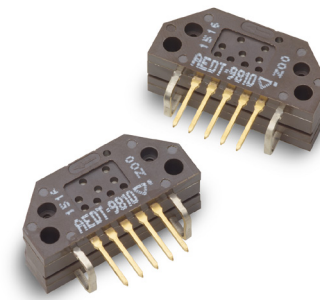

Description

Avago Technologies' AEDT-981x encoders are industrial grade high temperature (-40 to 115°C) rating three channel optical incremental encoder modules building on the Avago legacy HEDS-9140 series.

Using an Avago developed opto ASIC with the built-in Interpolator circuit, AEDT-981x encoders enable wide resolution range from 2000 to 5000 count per revolution with the rotary codewheel of 11mm optical radius, offering a high resolution yet compact solution.

With the opto-ASIC's built-in automatic LED brightness regulation technique, the encoder current consumption can be significantly lowered (Typ. I_{cc}: 20mA) while maintaining optimal encoder performance across spatial corners. This LED brightness control feature also enables optimal LED current control hence LED life can significantly pro-longed.

With the state of the art opto-mechanical design, AEDT-981x offers excellent spatial play of Ø 0.40mm and code wheel gap range of ±150µm. This allows great flexibility and ease of installation to the user.

Inheriting the indefeasible integrity in product robustness, repeatability and reliability, AEDT-981x series are designed for wide market employment withstanding wide application requirement and environment demand.

Features

- -40°C to 115°C Operating Temperature
- Two Channel Quadrature Output with Index Pulse
- Single ended output with ±5mA output sink/source current per channel
- Suitable for Industrial Applications
- Resolution up to 5000 Counts per Revolution
- Low Power Consumption (Typical I_{cc}: 20 mA)
- No Signal Adjustment Required
- Pin Compatible to legacy HEDS-9xxx Series
- Spatial play tolerance of Ø 0.40mm
- Allows motor shaft axial play of ±0.15mm
- ESD Immunity HBM 4kV (JESD22-A114D)

Applications

The AEDT-981x series provide high temperature motion control detection with ease of installation, making them suitable for wide range of commercial & industrial applications.

Note: Avago Technologies encoders are not recommended for use in safety critical applications. Eg. ABS braking systems, power steering, life support systems and critical care medical equipment. Please contact sales representative if more clarification is needed.

CAUTION: It is advised that normal static precautions be taken in handling and assembly of this component to prevent damage and/or degradation which may be induced by ESD.

Package Dimensions

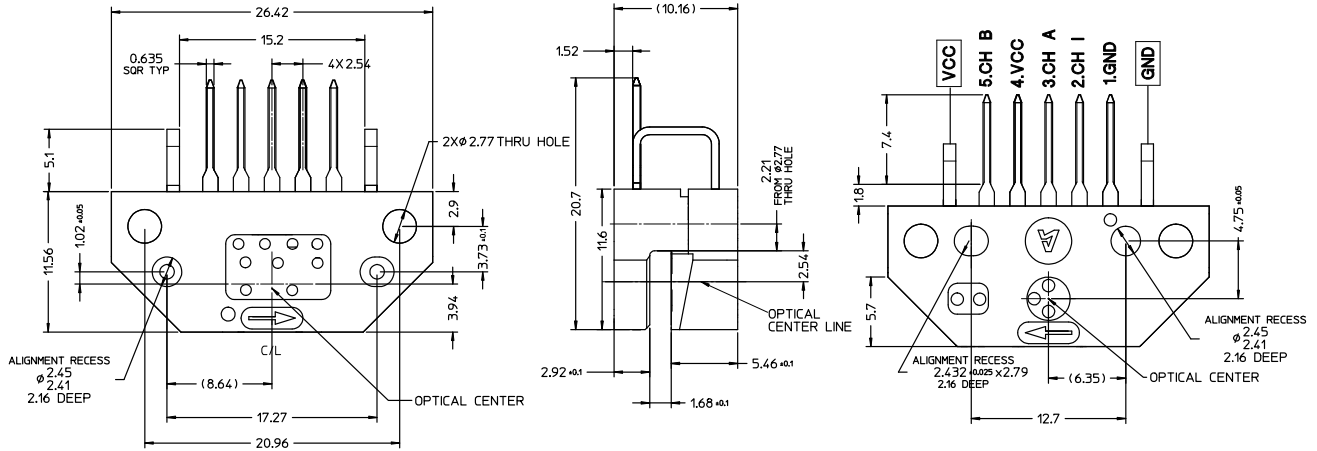

Figure 1.

Mounting Considerations with Aligning Pin

The AEDT-981X can be mounted using fixed aligning pins on the motor base. For this configuration, Side A or B can be used as the mounting plane as shown.

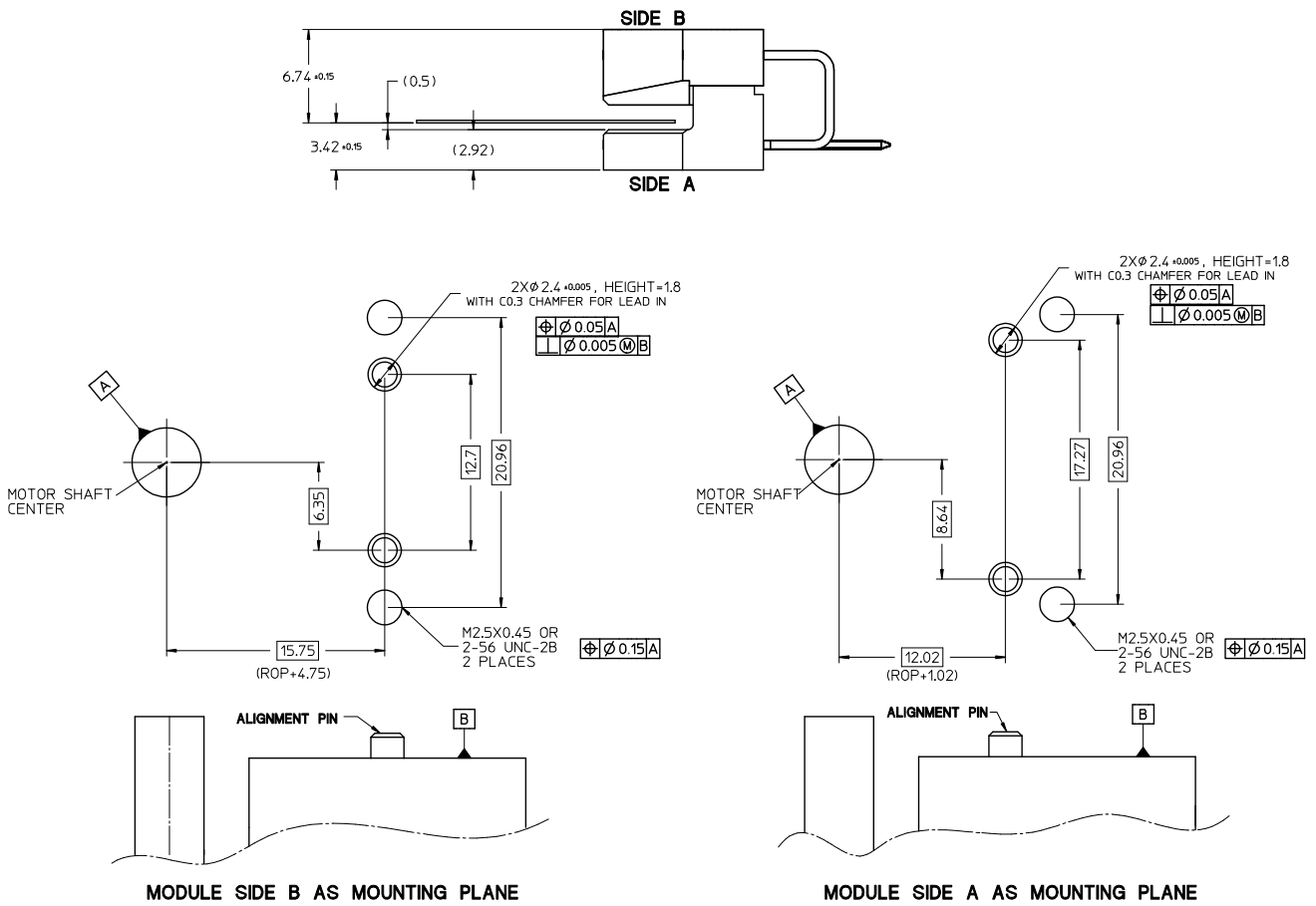

Figure 2.

Orientation of Artwork for Codewheels

The Index area on the AEDT-981X series encoder modules has a nonsymmetrical pattern as does the mating Codewheel. In order for the Index to operate, the "Rightreading" side of the Codewheel disk (the "Artwork Side") must point toward "Side A" of the Module (the side with the connecting pins).

Because the Encoder Module may be used with either "Side A" or with "Side B" toward the mounting surface, care must be taken to orientate the code wheel artwork side according to Figure below.

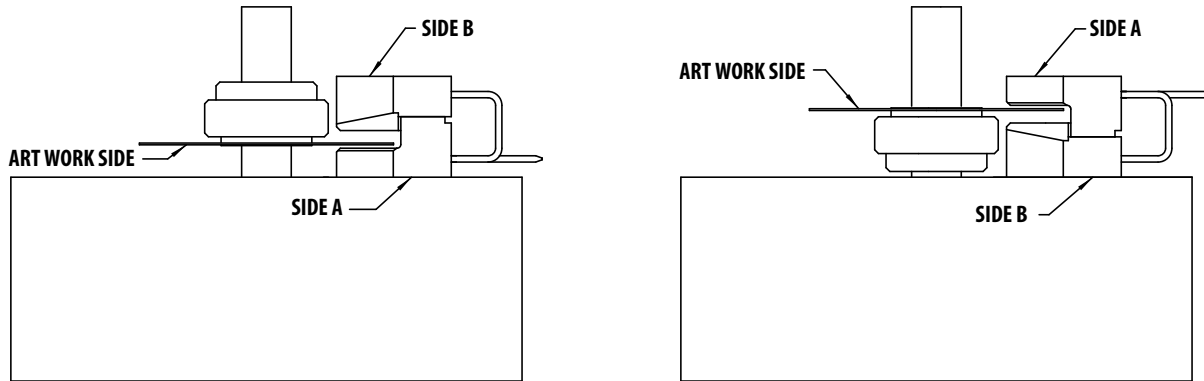
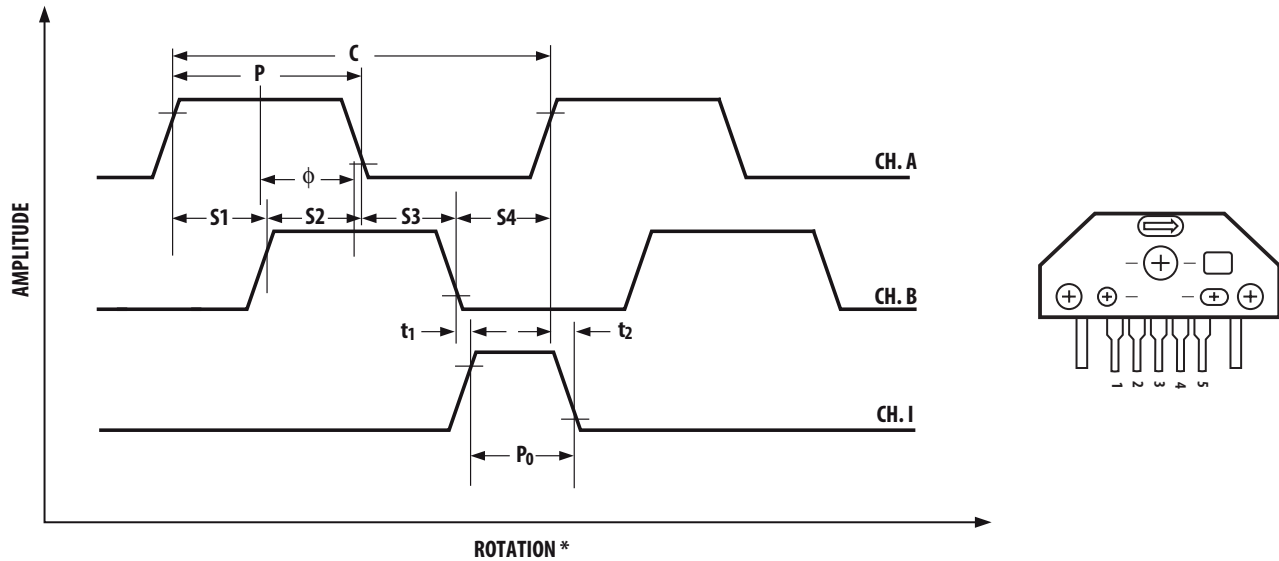

Figure 3.

Output Waveforms



* SPIN DIRECTION FOLLOWS ARROW MARKING ON ENCODER

Figure 4.

Definitions

Count (N): The number of bar and window pairs or counts per revolution (CPR) of the codewheel

One Cycle (C): 360 electrical degrees ($^{\circ}$ e), 1 bar and window pair

One Shaft Rotation: 360 mechanical degrees, N cycles

Position Error ($\Delta\theta$): The normalized angular difference between the actual shaft position and the position indicated by the encoder cycle count

Cycle Error (ΔC): An indication of cycle uniformity. The difference between an observed shaft angle which gives rise to one electrical cycle, and the nominal angular increment of $1/N$ of a revolution

Pulse Width (P): The number of electrical degrees that an output is high during 1 cycle. This value is nominally 180° e or $1/2$ cycle

Pulse Width Error (ΔP): The deviation, in electrical degrees, of the pulse width from its ideal value of 180° e

State Width (S): The number of electrical degrees between a transition in the output of channel A and the neighboring transition in the output of channel B. There are 4 states per cycle, each nominally 90° e.

State Width Error (ΔS): The deviation, in electrical degrees, of each state width from its ideal value of 90° e.

Phase (ϕ): The number of electrical degrees between the center of the high state of channel A and the center of the high state of channel B. This value is nominally 90° e for quadrature output.

Phase Error ($\Delta\phi$): The deviation of the phase from its ideal value of 90° e.

Direction of Rotation: When the codewheel rotates in the direction of the arrow on top of the module, channel A will lead channel B. If the codewheel rotates in the opposite direction, channel B will lead channel A.

Optical Radius (R_{OP}): The distance from the codewheel's center of rotation to the optical center (O.C.) of the encoder module.

Index Pulse Width (P_0): The number of electrical degrees that an index is high during one full shaft rotation. This value is nominally 90° e or $1/4$ cycle.

Absolute Maximum Ratings

Parameter	Symbol	Minimum	Maximum	Units
Storage Temperature	T _S	-40	125	°C
Operating Temperature	T _A	-40	115	°C
Supply Voltage	V _{CC}	-0.5	7	V
Output Voltage	V _O	-0.5	V _{CC}	V
Output Current per Channel	I _{OUT}		±5	mA
Velocity			12,000**	RPM

Note **: Velocity 12000 RPM applies to 5000 Count per Revolution

Recommended Operating Conditions

Parameter	Symbol	Min.	Typ.	Max.	Units	Notes
Temperature	T _A	-40		115	°C	
Supply Voltage	V _{CC}	4.5	5.0	5.5	Volt	Ripple < 100 mVp-p
Load Capacitance	C _L			100	pF	
Output Frequency	f			500	kHz	2000 – 2500 CPR
				1,000	kHz	4000 – 5000 CPR
Shaft Perpendicularity Plus Axial Displacement				± 0.15 (± 0.006)	mm (in.)	
Spatial play (including shaft eccentricity)				Ø0.40 (0.016)	mm (in.)	

Encoding Characteristics

Encoding characteristics are applicable per the Recommended Operating Conditions, unless otherwise specified. Values are for the worst case error over the full rotation.

Encoder Resolution ≥ 4000 CPR

Parameter	Symbol	Min	Typ.*	Max	Units
Pulse Width Error	ΔP		21	45	°e
Logic State Width Error	ΔS		17	45	°e
Phase Error	Δφ		12	25	°e
Cycle Error	ΔC		36	60	°e
Index Pulse Width	P ₀	65	90	115	°e

Encoder Resolution ≤ 2500 CPR

Parameter	Symbol	Min	Typ.*	Max	Units
Pulse Width Error	ΔP		20	30	°e
Logic State Width Error	ΔS		15	25	°e
Phase Error	Δφ		10	15	°e
Cycle Error	ΔC		17	30	°e
Index Pulse Width	P ₀	72	90	108	°e

* Typical values specified at V_{CC} = 5.0V and 25°C and for single ended, unless otherwise stated

Electrical Characteristics

Electrical Characteristics over Recommended Operating Range

Parameter	Symbol	Min.	Typ.*	Max.	Units	Notes
Supply Current	I_{CC}		20	80	mA	No load
High Level Output Voltage	V_{OH}	2.4			V	$I_{OH} = -5 \text{ mA}$
Low Level Output Voltage	V_{OL}			0.4	V	$I_{OL} = 5 \text{ mA}$.
Rise Time	t_r		10		ns	$C_L = 100 \text{ pF}$ at $\pm 5 \text{ mA}$
Fall Time	t_f		10		ns	$C_L = 100 \text{ pF}$ at $\pm 5 \text{ mA}$

*Typical values specified at $V_{CC} = 5.0 \text{ V}$, 25°C and nominal sensor position.

Electrical Interface

The AEDT-918x Series encoders output circuitry are designed with high speed and high drivability sink/source output of $\pm 5 \text{ mA}$ without the need of pull up resistors. The high drivability offers rail to rail V_{OH} and V_{OL} , giving the end customer better noise margin in signal processing hence more reliable in industrial application.

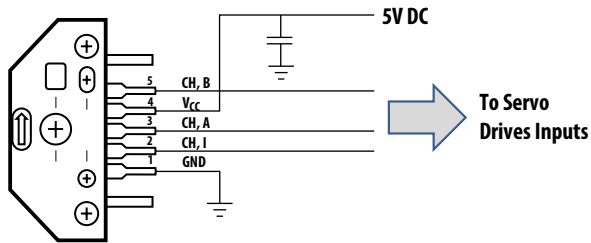

Figure 5.

Connectors

Manufacturer	Part Number
AMP	103686-4
	640442-5
Avago	HEDS-8902 (2 ch.) with 4-wire Leads
	HEDS-8903 (3 ch.) with 5-wire Leads
Molex	2695 series with 2759 series term.

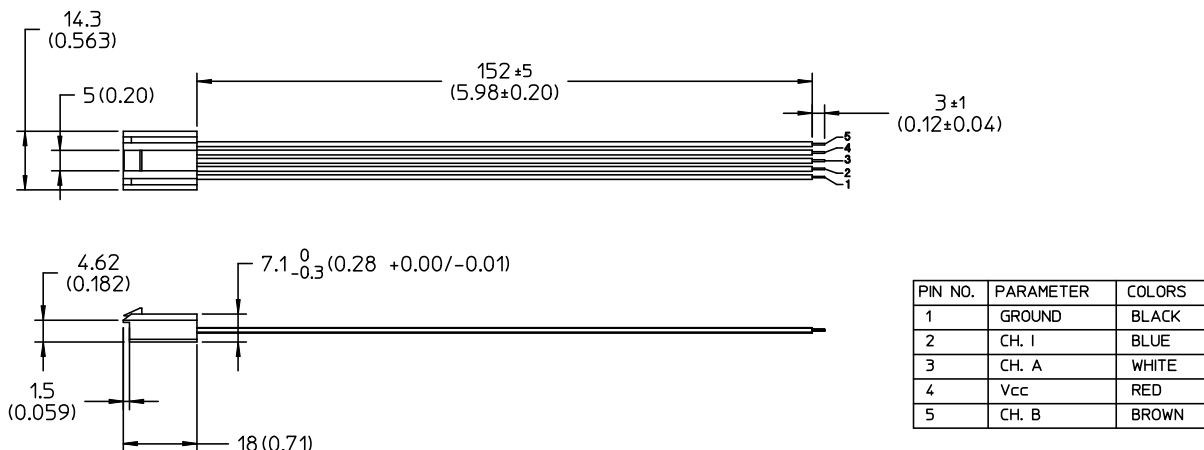
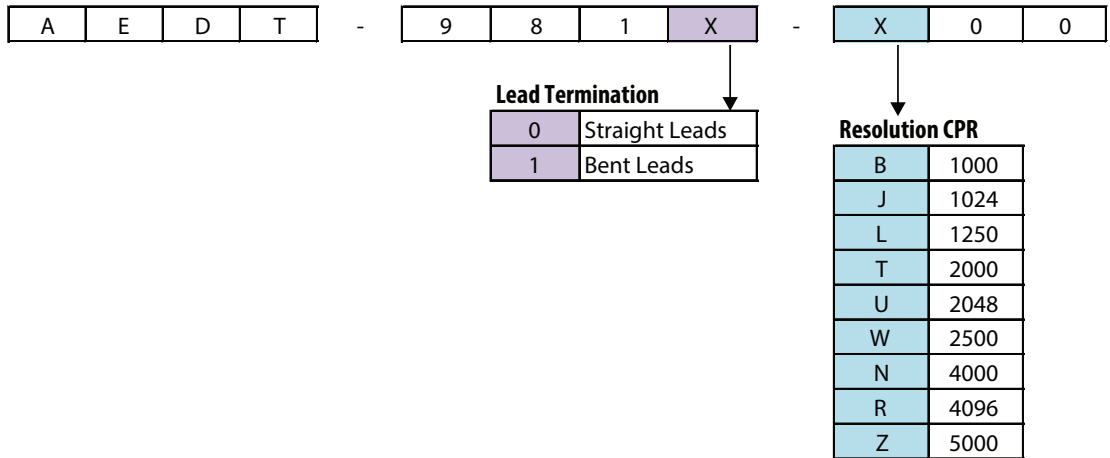

Figure 6.

Ordering Information

Three Channel Encoder Modules



DISCLAIMER: Avago's products and software are not specifically designed, manufactured or authorized for sale as parts, components or assemblies for the planning, construction, maintenance or direct operation of a nuclear facility or for use in medical devices or applications. Customer is solely responsible, and waives all rights to make claims against Avago or its suppliers, for all loss, damage, expense or liability in connection with such use.

For product information and a complete list of distributors, please go to our web site: www.avagotech.com

Avago, Avago Technologies, and the A logo are trademarks of Avago Technologies in the United States and other countries. Data subject to change. Copyright © 2005-2015 Avago Technologies. All rights reserved.
AV02-4924EN - June 2, 2015

AVAGO
TECHNOLOGIES