

## 阅读申明

- 1.本站收集的数据手册和产品资料都来自互联网，版权归原作者所有。如读者和版权方有任何异议请及时告之，我们将妥善解决。
- 2.本站提供的中文数据手册是英文数据手册的中文翻译，其目的是协助用户阅读，该译文无法自动跟随原稿更新，同时也可能存在翻译上的不当。建议读者以英文原稿为参考以便获得更精准的信息。
- 3.本站提供的产品资料，来自厂商的技术支持或者使用者的心得体会等，其内容可能存在描述上的差异，建议读者做出适当判断。
- 4.如需与我们联系，请发邮件到marketing@iczoom.com，主题请标有“数据手册”字样。

## Read Statement

1. The datasheets and other product information on the site are all from network reference or other public materials, and the copyright belongs to the original author and original published source. If readers and copyright owners have any objections, please contact us and we will deal with it in a timely manner.
2. The Chinese datasheets provided on the website is a Chinese translation of the English datasheets. Its purpose is for reader's learning exchange only and do not involve commercial purposes. The translation cannot be automatically updated with the original manuscript, and there may also be improper translations. Readers are advised to use the English manuscript as a reference for more accurate information.
3. All product information provided on the website refer to solutions from manufacturers' technical support or users the contents may have differences in description, and readers are advised to take the original article as the standard.
4. If you have any questions, please contact us at marketing@iczoom.com and mark the subject with "Datasheets" .

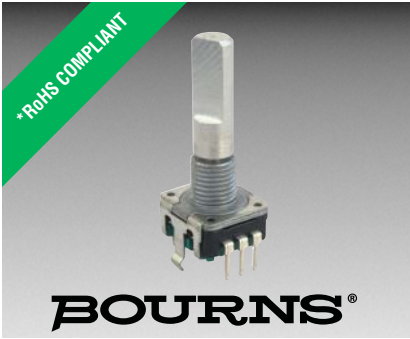

## Features

- Push switch option
- Compact, rugged design
- High reliability
- Metal bushing/shaft



Model PEC11 is currently available, but will be replaced by the Model PEC11R per [Product Change Notification](#) details.

# PEC11 Series - 12 mm Incremental Encoder

## Electrical Characteristics

Output.....	2-bit quadrature code
Closed Circuit Resistance .....	3 ohms maximum
Contact Rating .....	1 mA @ 5 VDC
Insulation Resistance .....	100 megohms @ 250 VDC
Dielectric Withstanding Voltage	
Sea Level.....	300 VAC minimum
Electrical Travel.....	Continuous
Contact Bounce (15 RPM).....	5.0 ms maximum**
RPM (Operating) .....	60 maximum**

## Environmental Characteristics

Operating Temperature Range .....	-30 °C to +70 °C (-22 °F to +158 °F)
Storage Temperature Range .....	-40 °C to +85 °C (-40 °F to +185 °F)
Humidity.....	MIL-STD-202, Method 103B, Condition B
Vibration .....	30 G
Contact Bounce .....	10~55~10 Hz / 1 min. / Amplitude 1.5 mm
Shock.....	100 G
Rotational Life.....	30,000 cycles minimum
Switch Life .....	20,000 cycles minimum
IP Rating.....	IP 40

## Mechanical Characteristics

Mechanical Angle .....	360 ° continuous
Torque	
Running .....	50 to 200 gf.cm (0.68 to 2.7 oz.-in.)
Mounting .....	10.2 kgf.cm (8.83 lb.-in.) maximum
Shaft Side Load (Static).....	2.04 kgf (4.5 lbs.) minimum
Weight .....	5 gm (0.17 oz.) maximum
Terminals .....	Printed circuit board terminals
Soldering Condition	
Wave Soldering .....	Sn95.5/Ag2.8/Cu0.7 solder with no-clean flux: 260 °C max. for 3-5 seconds
Hand Soldering .....	Not recommended
Hardware.....	One flat washer and one mounting nut supplied with each encoder

## Switch Characteristics

Switch Type .....	Contact Push ON Momentary SPST
Power Rating (Resistive Load).....	10 mA at 5 V DC
Switch Travel .....	0.5 ± 0.2 mm
Switch Actuation Force.....	610 ± 306 gf (8.47 ± 4.24 oz.-in.)

## How To Order

**PEC11 - 4 0 20 F - S 0012**

Model .....	PEC11 - 4 0 20 F - S 0012
Terminal Configuration .....	4 = PC Pin Horizontal/Rear Facing
Detent Option .....	0 = No Detents (12, 18, 24 pulses) 1 = 18 Detents (18 pulses) 2 = 24 Detents (12, 24 pulses) 3 = 12 Detents (12 pulses)
Standard Shaft Length .....	15 = 15.0 mm 20 = 20.0 mm 25 = 25.0 mm 30 = 30.0 mm
Shaft Style .....	F = Metal Flatted Shaft K = Metal Knurled Shaft <sup>1</sup>
Switch Configuration .....	S = Push Momentary Switch N = No Switch
Resolution .....	0012 = 12 Pulses per 360 ° Rotation 0018 = 18 Pulses per 360 ° Rotation 0024 = 24 Pulses per 360 ° Rotation

<sup>1</sup> Metal knurled shaft with no switch is available in 15, 20 and 30 mm shaft lengths.  
Metal knurled shaft with push momentary switch is available in 15 and 20 mm shaft lengths.

## Quadrature Output Table

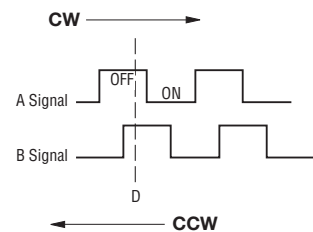

\*RoHS Directive 2002/95/EC Jan 27, 2003 including Annex.

\*\*Devices are tested using standard noise reduction filters. For optimum performance, designers should use noise reduction filters in their circuits.

Specifications are subject to change without notice.

Customers should verify actual device performance in their specific applications.

## Applications

Level control, tuning and timer settings in:

- Audio-visual equipment
- Consumer electric appliances
- Radios
- Musical instrumentation
- Communications equipment



## PEC11 Series - 12 mm Incremental Encoder

**BOURNS®**

### Product Dimensions

#### PEC11-4xxxF-Nxxxx



#### PEC11-4xxxF-Sxxxx



L1	LB	l
$\frac{15}{(.591)}$	$\frac{5.0}{(.197)}$	$\frac{7.0}{(.276)}$
$\frac{20}{(.787)}$	$\frac{7.0}{(.276)}$	$\frac{10.0}{(.394)}$
$\frac{25}{(.984)}$	$\frac{7.0}{(.276)}$	$\frac{12.0}{(.472)}$
$\frac{30}{(1.181)}$	$\frac{7.0}{(.276)}$	$\frac{12.0}{(.472)}$

# PEC11 Series - 12 mm Incremental Encoder

**BOURNS®**

## Product Dimensions

### PEC11-4xxxK-Nxxxx



L	LB	P	A
15 (.591)	5.0 (.197)	7.0 (.276)	6.0 (.236)
20 (.787)	7.0 (.276)	7.0 (.276)	6.0 (.236)
30 (1.181)	7.0 (.276)	16.0 (.630)	12.0 (.472)

### PEC11-4xxxK-Sxxxx

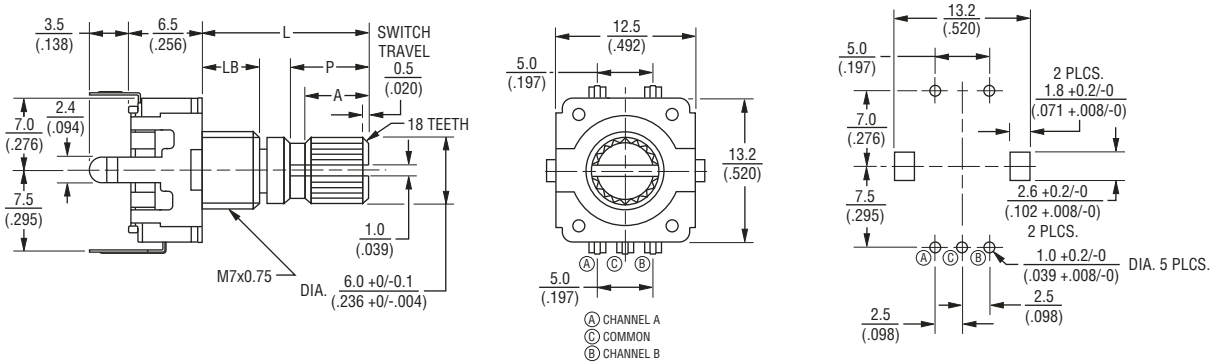

L	LB	P	A
15 (.591)	5.0 (.197)	7.0 (.276)	6.0 (.236)
20 (.787)	7.0 (.276)	7.0 (.276)	6.0 (.236)

DIMENSIONS:  $\frac{\text{MM}}{\text{(INCHES)}}$