

## 阅读申明

- 1.本站收集的数据手册和产品资料都来自互联网，版权归原作者所有。如读者和版权方有任何异议请及时告之，我们将妥善解决。
- 2.本站提供的中文数据手册是英文数据手册的中文翻译，其目的是协助用户阅读，该译文无法自动跟随原稿更新，同时也可能存在翻译上的不当。建议读者以英文原稿为参考以便获得更精准的信息。
- 3.本站提供的产品资料，来自厂商的技术支持或者使用者的心得体会等，其内容可能存在描述上的差异，建议读者做出适当判断。
- 4.如需与我们联系，请发邮件到marketing@iczoom.com，主题请标有“数据手册”字样。

## Read Statement

1. The datasheets and other product information on the site are all from network reference or other public materials, and the copyright belongs to the original author and original published source. If readers and copyright owners have any objections, please contact us and we will deal with it in a timely manner.
2. The Chinese datasheets provided on the website is a Chinese translation of the English datasheets. Its purpose is for reader's learning exchange only and do not involve commercial purposes. The translation cannot be automatically updated with the original manuscript, and there may also be improper translations. Readers are advised to use the English manuscript as a reference for more accurate information.
3. All product information provided on the website refer to solutions from manufacturers' technical support or users the contents may have differences in description, and readers are advised to take the original article as the standard.
4. If you have any questions, please contact us at marketing@iczoom.com and mark the subject with "Datasheets" .



## TLE4941 / 4941C

Smart Hall Effect ICs for Active Wheel Speed Sensing

### Applications

- Modern ABS systems
- Transmission speed sensing

### Features

- No external components needed
- Frequency range from 1 to 5000 Hz
- Two wire standard current interface
- Dynamic self-calibration principle
- Excellent sensitivity (min  $\Delta B < 1.5$  mT)
- South and North pole pre-induction possible
- Ultra thin PG-SSO package
- 1.8 nF overmoulded capacitor for enhanced EMC (C-versions)
- Single chip solution
- Output switching with 1 st magnetic edge (-1 versions)

### Functional Description

THE DIFFERENTIAL Hall sensor IC detects the motion of ferromagnetic and permanent magnet structures by measuring the differential flux density of the magnetic field. To detect the motion of ferromagnetic objects the magnetic field must be provided by a back biasing permanent magnet. Magnetic and device offsets are cancelled by a self-calibration algorithm within a few transitions. The ON and OFF state of the IC are indicated by High and Low current consumption.

PG-SSO-2-2

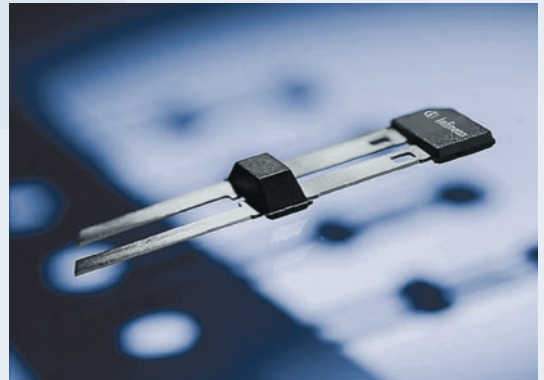

[www.infineon.com/sensors](http://www.infineon.com/sensors)

Sensors



Never stop thinking

## Block Diagram

TLE4941 signal path is comprised of a pair of hall probes, spaced at 2.5 mm, a differential amplifier including a noise-limiting low-pass filter, and a comparator feeding a switched current output stage.

IN ADDITION an offset cancellation feedback loop is provided by a signal-tracking A/D converter, a digital signal processor (DSP) and an offset cancellation D/A converter.

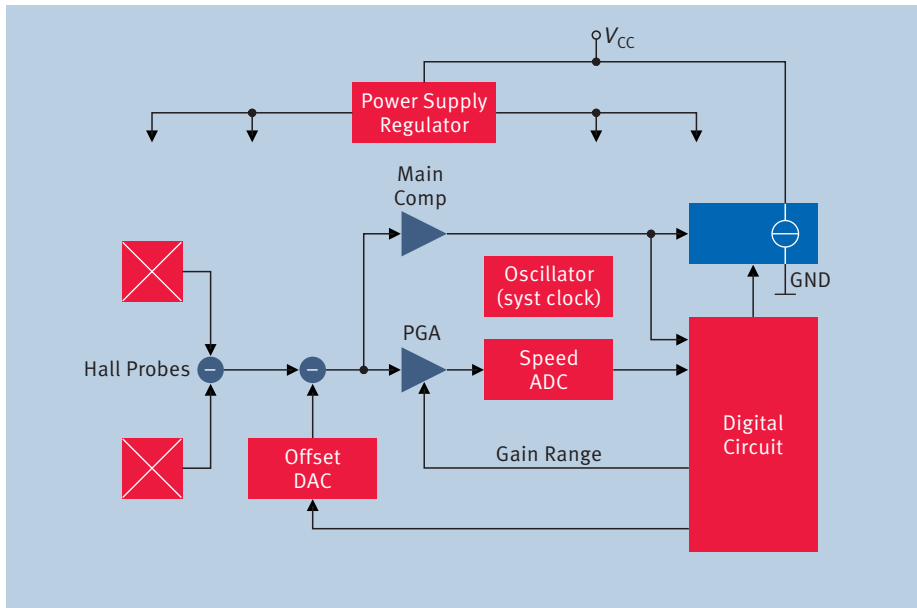

Parameter	Value	Unit
Operating voltage	4.5 ... 20	V
Supply current (L/H)	7 / 14	mA
Min magn. flux density	< 1.5	mT
Power on time	< 1	msec
Frequency range	< 1 ... 5000	Hz
Temperature range	-40 ... +150	°C
Jitter	< 2	%

## Interface Description

TLE4941 outputs a conventional square wave signal for speed frequency.

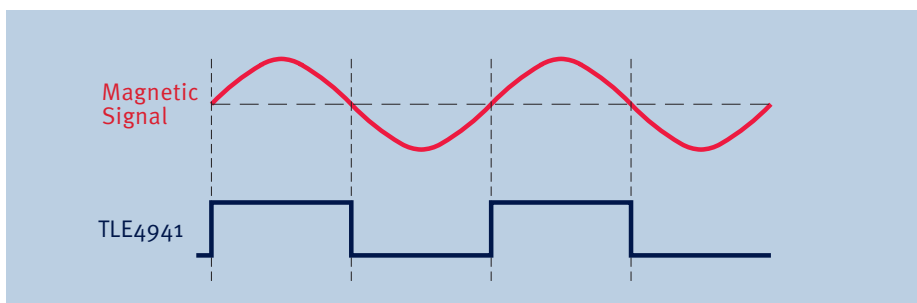

Type	Sales Code	Package
TLE4941	Q62705-K714	PG-SSO-2-1
TLE4941C	Q62705-K715	PG-SSO-2-2
TLE4941-1	Q62705-K719	PG-SSO-2-1
TLE4941-1C	Q62705-K712	PG-SSO-2-2

How to reach us:  
<http://www.infineon.com>

Published by  
 Infineon Technologies AG  
 81726 München, Germany

© Infineon Technologies AG 2006.  
 All Rights Reserved.

### Legal Disclaimer

The information given in this Product Brief shall in no event be regarded as a guarantee of conditions or characteristics ("Beschaffenheitsgarantie"). With respect to any examples or hints given herein, any typical values stated herein and/or any information regarding the application of the device, Infineon Technologies hereby disclaims any and all warranties and liabilities of any kind, including without limitation warranties of non-infringement of intellectual property rights of any third party.

### Information

For further information on technology, delivery terms and conditions and prices please contact your nearest Infineon Technologies Office ([www.infineon.com](http://www.infineon.com)).

### Warnings

Due to technical requirements components may contain dangerous substances. For information on the types in question please contact your nearest Infineon Technologies Office.

Infineon Technologies Components may only be used in life-support devices or systems with the express written approval of Infineon Technologies, if a failure of such components can reasonably be expected to cause the failure of that life-support device or system, or to affect the safety or effectiveness of that device or system. Life support devices or systems are intended to be implanted in the human body, or to support and/or maintain and sustain and/or protect human life. If they fail, it is reasonable to assume that the health of the user or other persons may be endangered.

Ordering No. B112-H7820-G1-X-7600  
 Printed in Germany  
 PS 03061. nb