

阅读申明

- 1.本站收集的数据手册和产品资料都来自互联网，版权归原作者所有。如读者和版权方有任何异议请及时告之，我们将妥善解决。
- 2.本站提供的中文数据手册是英文数据手册的中文翻译，其目的是协助用户阅读，该译文无法自动跟随原稿更新，同时也可能存在翻译上的不当。建议读者以英文原稿为参考以便获得更精准的信息。
- 3.本站提供的产品资料，来自厂商的技术支持或者使用者的心得体会等，其内容可能存在描述上的差异，建议读者做出适当判断。
- 4.如需与我们联系，请发邮件到marketing@iczoom.com，主题请标有“数据手册”字样。

Read Statement

1. The datasheets and other product information on the site are all from network reference or other public materials, and the copyright belongs to the original author and original published source. If readers and copyright owners have any objections, please contact us and we will deal with it in a timely manner.
2. The Chinese datasheets provided on the website is a Chinese translation of the English datasheets. Its purpose is for reader's learning exchange only and do not involve commercial purposes. The translation cannot be automatically updated with the original manuscript, and there may also be improper translations. Readers are advised to use the English manuscript as a reference for more accurate information.
3. All product information provided on the website refer to solutions from manufacturers' technical support or users the contents may have differences in description, and readers are advised to take the original article as the standard.
4. If you have any questions, please contact us at marketing@iczoom.com and mark the subject with "Datasheets" .

New



Thin short type
(Mounting direction: V type)



Short type
(Mounting direction: H type)



Middle type
(Mounting direction: H type)



Long type
(Mounting direction: H type)



Long type
(Mounting direction: V type)

What is area reflective type?

The sensor emits a ray of light toward the human body and detects the distance and determine whether there is a person within a given distance of the sensor. If the sensor detects a person, it sets an output non-contact switch to ON.

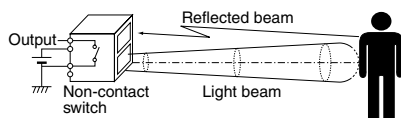

Compliance with RoHS Directive

FEATURES

1. Now even more miniature.

The new thin type cuts 35% from the thickness of the previous short type. Device installing is now easier than ever.

Existing short type
W10 x H20 x D19.5 mm
W.394 x H.787 x D.768 inch

Thin short type
W10 x H20 x D12.7 mm
W.394 x H.787 x D.500 inch

*"W" and "H" are detection value measurements.

2. Certain detection unaffected by the reflectance of the object

The sensor can provide stable detection that is not affected by the condition (color or material of the clothing) or parts (skin, hair, etc.) of the object being monitored. (Reflectance 18% to 90%). Excellent performance even when the detection surface is dirty.

3. Only connecting DC power supply for operating

Built-in oscillation circuit type obviates the hitherto existing need for start signal input.

4. Use in adjacent positions is possible

These sensors can be located in adjacent positions, because the timing of the external trigger signals can be adjusted so that the beam frequency of each adjacent sensor will not interfere with the other.

5. Battery drive possible

By applying longer interval for the trigger signal, you can reduce the total power consumption.

6. Can be used with a number of different supply voltages.

- 1) The 5V DC type (4.5 to 6.5V DC)
- 2) The free-ranging power type (6.5 to 27V DC)

They support the DC power supplies of electronic products and equipment in general.

*The thin short type is only available for 5V DC.

7. The open collector output system makes for easy load drive.

These sensors provide a continuous output during detection because the output system makes it easy to drive the load.

They achieve an output performance of 30V, Built-in oscillation circuit type: 100 mA, External triggering type: 10 mA (Thin short type: 100 mA). Also, the thin short type is available in a PNP open collector type in addition to a NPN open collector type.

APPLICATIONS

1. Water-based product market

- Automatic lighting of wash basin units
- Toilets

2. Stores and financial instructions

- Automatic doors
- Automatic lighting
- Cash dispensing machines
- Automatic teller machines

3. Amusement market

- Automatic lighting for game display

4. Medical field

- Non-contact switch

5. Others

- Automatic ticket gates
- Seat-taking sensors
- Detection of passengers getting on and off a bus

ORDERING INFORMATION

AM

MA Motion Sensor

A: Thin short type MA Motion sensor

B: MA Motion sensor

Detection distance type (shape)

1: Short type

2: Middle type

3: Long type

Triggering function

1: External triggering type

4: Built-in oscillation circuit type (Internal trigger)

Classification by output method & mounting direction

0: NPN open collector/H type

5: NPN open collector/V type

6: PNP open collector/V type

Operating voltage

2: Free-ranging power type (6.5 to 27V DC)

9: The DC 5V type (4.5 to 6.5V DC)

Rated detection distance

Part No.	cm inch																		
	02	03	04	05	06	07	08 (Middle type does not need 08)	09	10 (Short type does not need 10)	11	12	13	14	15	16	17	18	19	20 (Long type does not need 20)
Thin short type	—	—	—	5 1.969	—	—	—	—	10 3.937	—	—	—	—	15 5.906	—	—	—	—	—
Short type	—	—	—	5 1.969	6 2.362	7 2.756	8 3.150	9 3.543	10 3.937	—	—	—	—	—	—	—	—	—	—
Middle type	20 7.874	30 11.811	40 15.748	50 19.685	60 23.622	70 27.559	80 31.496	—	—	—	—	—	—	—	—	—	—	—	—
Long type	—	30 11.811	40 15.748	50 19.685	60 23.622	70 27.559	80 31.496	90 35.433	100 39.37	110 43.307	120 47.244	130 51.181	140 55.118	150 59.055	160 62.992	170 66.929	180 70.866	190 74.803	200 78.74

DETECTION DISTANCE TYPE (distance limited)

1. Thin short type (V type)

Mounting direction	Type (shape)	Operating voltage	Output method	Rated detection distance	Part No.		Packing quantity	
					Built-in oscillation circuit type	External triggering type	Inner	Outer
V type	Thin short type	4.5 to 6.5 V DC	NPN open collector output	5 cm 1.969 inch	AMA145905	AMA115905	20 pcs.	200 pcs.
				10 cm 3.937 inch	AMA1459	AMA1159		
				15 cm 5.906 inch	AMA145915	AMA115915		
			PNP open collector output	5 cm 1.969 inch	AMA146905	AMA116905		
				10 cm 3.937 inch	AMA1469	AMA1169		
				15 cm 5.906 inch	AMA146915	AMA116915		

Note: If you plan to use multiple sensors side-by-side, or you wish to keep the current consumption small, inquire for details about external trigger type, which is suitable for such applications.

2. Short type (H type)

Mounting direction	Type (shape)	Rated operating voltage	Rated detection distance	Part No.		Packing quantity	
				Built-in oscillation circuit type	External triggering type	Inner	Outer
H type	Short type	4.5 to 6.5 V DC	5 cm 1.969 inch	AMB140905	AMB110905	20 pcs.	200 pcs.
			6 cm 2.362 inch	AMB140906	AMB110906		
			7 cm 2.756 inch	AMB140907	AMB110907		
			8 cm 3.150 inch	AMB140908	AMB110908		
			9 cm 3.543 inch	AMB140909	AMB110909		
			10 cm 3.937 inch	AMB1409	AMB1109		
		6.5 to 27 V DC	5 cm 1.969 inch	AMB140205	AMB110205		
			6 cm 2.362 inch	AMB140206	AMB110206		
			7 cm 2.756 inch	AMB140207	AMB110207		
			8 cm 3.150 inch	AMB140208	AMB110208		
			9 cm 3.543 inch	AMB140209	AMB110209		
			10 cm 3.937 inch	AMB1402	AMB1102		

Note: If you plan to use multiple sensors side-by-side, or you wish to keep the current consumption small, inquire for details about external trigger type, which is suitable for such applications.

3. Middle type (H type)

Mounting direction	Type (shape)	Rated operating voltage	Rated detection distance	Part No.		Packing quantity	
				Built-in oscillation circuit type	External triggering type	Inner	Outer
H type	Middle type	4.5 to 6.5 V DC	20 cm 7.874 inch	AMB240902	AMB210902	20 pcs.	200 pcs.
			30 cm 11.811 inch	AMB240903	AMB210903		
			40 cm 15.748 inch	AMB240904	AMB210904		
			50 cm 19.685 inch	AMB240905	AMB210905		
			60 cm 23.622 inch	AMB240906	AMB210906		
			70 cm 27.559 inch	AMB240907	AMB210907		
			80 cm 31.496 inch	AMB2409	AMB2109		
			20 cm 7.874 inch	AMB240202	AMB210202		
	6.5 to 27 V DC	30 cm 11.811 inch	AMB240203	AMB210203			
		40 cm 15.748 inch	AMB240204	AMB210204			
		50 cm 19.685 inch	AMB240205	AMB210205			
		60 cm 23.622 inch	AMB240206	AMB210206			
		70 cm 27.559 inch	AMB240207	AMB210207			
		80 cm 31.496 inch	AMB2402	AMB2102			

Note: If you plan to use multiple sensors side-by-side, or you wish to keep the current consumption small, inquire for details about external trigger type, which is suitable for such applications.

4. Long type (H type)

Mounting direction	Type (shape)	Rated operating voltage	Rated detection distance	Part No.		Packing quantity		
				Built-in oscillation circuit type	External triggering type	Inner	Outer	
H type	Long type	4.5 to 6.5 V DC	30 cm 11.811 inch	AMB340903	AMB310903	20 pcs.	200 pcs.	
			40 cm 15.748 inch	AMB340904	AMB310904			
			50 cm 19.685 inch	AMB340905	AMB310905			
			60 cm 23.622 inch	AMB340906	AMB310906			
			70 cm 27.559 inch	AMB340907	AMB310907			
			80 cm 31.496 inch	AMB340908	AMB310908			
			90 cm 35.433 inch	AMB340909	AMB310909			
			100 cm 39.370 inch	AMB340910	AMB310910			
			110 cm 43.307 inch	AMB340911	AMB310911			
			120 cm 47.244 inch	AMB340912	AMB310912			
			130 cm 51.181 inch	AMB340913	AMB310913			
			140 cm 55.118 inch	AMB340914	AMB310914			
			150 cm 59.055 inch	AMB340915	AMB310915			
			160 cm 62.992 inch	AMB340916	AMB310916			
			170 cm 66.929 inch	AMB340917	AMB310917			
			180 cm 70.866 inch	AMB340918	AMB310918			
			190 cm 74.803 inch	AMB340919	AMB310919			
			200 cm 78.740 inch	AMB3409	AMB3109			
			6.5 to 27 V DC	30 cm 11.811 inch	AMB340203			AMB310203
				40 cm 15.748 inch	AMB340204			AMB310204
	50 cm 19.685 inch	AMB340205		AMB310205				
	60 cm 23.622 inch	AMB340206		AMB310206				
	70 cm 27.559 inch	AMB340207		AMB310207				
	80 cm 31.496 inch	AMB340208		AMB310208				
	90 cm 35.433 inch	AMB340209		AMB310209				
	100 cm 39.370 inch	AMB340210		AMB310210				
	110 cm 43.307 inch	AMB340211		AMB310211				
	120 cm 47.244 inch	AMB340212		AMB310212				
	130 cm 51.181 inch	AMB340213		AMB310213				
	140 cm 55.118 inch	AMB340214		AMB310214				
	150 cm 59.055 inch	AMB340215		AMB310215				
	160 cm 62.992 inch	AMB340216		AMB310216				

Note: If you plan to use multiple sensors side-by-side, or you wish to keep the current consumption small, inquire for details about external trigger type, which is suitable for such applications.

5. Long type (V type)

Mounting direction	Type (shape)	Rated operating voltage	Rated detection distance	Part No.		Packing quantity	
				Built-in oscillation circuit type	External triggering type	Inner	Outer
V type	Long type	4.5 to 6.5 V DC	30 cm 11.811 inch	AMB345903	AMB315903	20 pcs.	200 pcs.
			40 cm 15.748 inch	AMB345904	AMB315904		
			50 cm 19.685 inch	AMB345905	AMB315905		
			60 cm 23.622 inch	AMB345906	AMB315906		
			70 cm 27.559 inch	AMB345907	AMB315907		
			80 cm 31.496 inch	AMB345908	AMB315908		
			90 cm 35.433 inch	AMB345909	AMB315909		
			100 cm 39.370 inch	AMB345910	AMB315910		
			110 cm 43.307 inch	AMB345911	AMB315911		
			120 cm 47.244 inch	AMB345912	AMB315912		
			130 cm 51.181 inch	AMB345913	AMB315913		
			140 cm 55.118 inch	AMB345914	AMB315914		
			150 cm 59.055 inch	AMB345915	AMB315915		
			160 cm 62.992 inch	AMB345916	AMB315916		
			170 cm 66.929 inch	AMB345917	AMB315917		
			180 cm 70.866 inch	AMB345918	AMB315918		
			190 cm 74.803 inch	AMB345919	AMB315919		
			200 cm 78.740 inch	AMB3459	AMB3159		
		6.5 to 27 V DC	30 cm 11.811 inch	AMB345203	AMB315203	20 pcs.	200 pcs.
			40 cm 15.748 inch	AMB345204	AMB315204		
			50 cm 19.685 inch	AMB345205	AMB315205		
			60 cm 23.622 inch	AMB345206	AMB315206		
			70 cm 27.559 inch	AMB345207	AMB315207		
			80 cm 31.496 inch	AMB345208	AMB315208		
			90 cm 35.433 inch	AMB345209	AMB315209		
			100 cm 39.370 inch	AMB345210	AMB315210		
			110 cm 43.307 inch	AMB345211	AMB315211		
			120 cm 47.244 inch	AMB345212	AMB315212		
			130 cm 51.181 inch	AMB345213	AMB315213		
			140 cm 55.118 inch	AMB345214	AMB315214		
			150 cm 59.055 inch	AMB345215	AMB315215		
			160 cm 62.992 inch	AMB345216	AMB315216		
			170 cm 66.929 inch	AMB345217	AMB315217		
			180 cm 70.866 inch	AMB345218	AMB315218		
190 cm 74.803 inch	AMB345219	AMB315219					
200 cm 78.740 inch	AMB3452	AMB3152					

Note: If you plan to use multiple sensors side-by-side, or you wish to keep the current consumption small, inquire for details about external trigger type, which is suitable for such applications.

PERFORMANCE

1. Detection performance (Measuring conditions: ambient temp.: 25°C 77°F; operating voltage: 5 V DC)

1) Thin short type

Items		Thin short type			Measured conditions
		5 cm 1.969 inch	10 cm 3.937 inch	15 cm 3.937 inch	
Rated detection distance	Minimum	45 mm	90 mm	135 mm	with a standard reflection board*1
	Typical	1.772 inch 50 mm	3.543 inch 100 mm	5.315 inch 150 mm	
	Maximum	1.969 inch 55 mm 2.165 inch	3.937 inch 110 mm 4.331 inch	5.906 inch 165 mm 6.496 inch	
Measuring tolerance	Typical	10%	25%	35%	Reflection rate: 90 to 18%
Usable ambient brightness (Resistance to ambient light)*2	Brightness of sensor surface	30,000 lx			See the drawing (Fig. 1) on the next page.
	Brightness of reflection surface	30,000 lx			

Notes: *1. Ambient brightness: 500 lx

*2. Install so that light from direct light sources does not enter the sensor (within 30x of the sensor light beam).

Indicates brightness detectable enough for sensor operation. (Measuring conditions: ambient temp.: 25°C 77°F; operating voltage: 5 V DC type 5V, Free-ranging power type 24V DC)

2) Short type

Items		Short type*1						Measured conditions
		5 cm 1.969 inch	6 cm 2.362 inch	7 cm 2.756 inch	8 cm 3.150 inch	9 cm 3.543 inch	10 cm 3.937 inch	
Rated detection distance	Minimum	45 mm	54 mm	63 mm	72 mm	81 mm	90 mm	with a standard reflection board
	Typical	1.772 inch 50 mm	2.126 inch 60 mm	2.480 inch 70 mm	2.835 inch 80 mm	3.189 inch 90 mm	3.543 inch 100 mm	
	Maximum	1.969 inch 55 mm	2.362 inch 66 mm	2.756 inch 77 mm	3.150 inch 88 mm	3.543 inch 99 mm	3.937 inch 110 mm	
Measuring tolerance	Typical	10%		15%	20%		25%	Reflection rate: 90 to 18%
Usable ambient brightness (Resistance to ambient light)*2	Brightness of sensor surface	Maximum 30,000 lx						See the drawing (Fig. 1) on the next page.
	Brightness of reflection surface	Maximum 30,000 lx						

Notes: *1. After receipt of order, average rated detection distance to 15 cm 5.906 inch is possible. Please inquire.
*2. Install so that light from direct light sources does not enter the sensor (within 30x of the sensor light beam).

3) Middle type (Measuring conditions: ambient temp.: 25xC 77xF; operating voltage: 5 V DC type 5V, Free-ranging power type 24V DC)

Items		Middle type*1						Measured conditions	
		20 cm 7.874 inch	30 cm 11.811 inch	40 cm 15.748 inch	50 cm 19.685 inch	60 cm 23.622 inch	70 cm 27.559 inch		80 cm 31.496 inch
Rated detection distance	Minimum	190 mm	285 mm	380 mm	475 mm	570 mm	665 mm	760 mm	with a standard reflection board
	Typical	7.480 inch 200 mm	11.220 inch 300 mm	14.961 inch 400 mm	18.701 inch 500 mm	22.441 inch 600 mm	26.181 inch 700 mm	29.921 inch 800 mm	
	Maximum	7.874 inch 210 mm	11.811 inch 315 mm	15.748 inch 420 mm	19.685 inch 525 mm	23.622 inch 630 mm	27.559 inch 735 mm	31.496 inch 840 mm	
Measuring tolerance	Typical	3%		5%		10%		Reflection rate: 90 to 18%	
Usable ambient brightness (Resistance to ambient light)*2	Brightness of sensor surface	Maximum 30,000 lx						See the drawing (Fig. 1) on the next page.	
	Brightness of reflection surface	Maximum 30,000 lx							

Notes: *1. After receipt of order, average rated detection distance to 110 cm 43.307 inch is possible. Please inquire.
*2. Install so that light from direct light sources does not enter the sensor (within 30x of the sensor light beam).

4) Long type (Measuring conditions: ambient temp.: 25xC 77xF; operating voltage: 5 V DC type 5V, Free-ranging power type 24V DC)

Items		Long type								Measured conditions	
		30 cm 11.811 inch	40 cm 15.748 inch	50 cm 19.685 inch	60 cm 23.622 inch	70 cm 27.559 inch	80 cm 31.496 inch	90 cm 35.433 inch	100 cm 39.37 inch		110 cm 43.307 inch
Rated detection distance	Minimum	285 mm	380 mm	475 mm	570 mm	665 mm	760 mm	855 mm	950 mm	1045 mm	with a standard reflection board
	Typical	11.220 inch 300 mm	14.961 inch 400 mm	18.701 inch 500 mm	22.441 inch 600 mm	26.181 inch 700 mm	29.921 inch 800 mm	33.661 inch 900 mm	37.402 inch 1000 mm	41.142 inch 1100 mm	
	Maximum	11.811 inch 315 mm	15.748 inch 420 mm	19.685 inch 525 mm	23.622 inch 630 mm	27.559 inch 735 mm	31.496 inch 840 mm	34.433 inch 945 mm	39.37 inch 1050 mm	43.307 inch 1155 mm	
Measuring tolerance	Typical	3%				5%				Reflection rate: 90 to 18%	
Usable ambient brightness (Resistance to ambient light)*	Brightness of sensor surface	Maximum 30,000 lx								See the drawing (Fig. 1) on the next page.	
	Brightness of reflection surface	Maximum 30,000 lx									

Items		Long type								Measured conditions	
		120 cm 47.244 inch	130 cm 51.181 inch	140 cm 55.118 inch	150 cm 59.055 inch	160 cm 62.992 inch	170 cm 66.929 inch	180 cm 70.866 inch	190 cm 74.803 inch		200 cm 78.74 inch
Rated detection distance	Minimum	1140 mm	1235 mm	1330 mm	1425 mm	1520 mm	1615 mm	1710 mm	1805 mm	1900 mm	with a standard reflection board
	Typical	44.882 inch 1200 mm	48.622 inch 1300 mm	52.362 inch 1400 mm	56.102 inch 1500 mm	59.842 inch 1600 mm	63.583 inch 1700 mm	67.323 inch 1800 mm	71.063 inch 1900 mm	74.803 inch 2000 mm	
	Maximum	47.244 inch 1260 mm	51.181 inch 1365 mm	55.118 inch 1470 mm	59.055 inch 1575 mm	62.992 inch 1680 mm	66.929 inch 1785 mm	70.866 inch 1890 mm	74.803 inch 1995 mm	78.74 inch 2100 mm	
Measuring tolerance	Typical	5%	10%			15%				Reflection rate: 90 to 18%	
Usable ambient brightness (Resistance to ambient light)*	Brightness of sensor surface	Maximum 30,000 lx								See the drawing (Fig. 1) on the next page.	
	Brightness of reflection surface	Maximum 30,000 lx									

Note: * Install so that light from direct light sources does not enter the sensor (within 30x of the sensor light beam).

- For thin short type:
Standard reflection board: 100 mm 3.937 inch square area,
90% reflection rate.
- For short type:
Standard reflection board: 100 mm 3.937 inch square area,
90% reflection rate.
- For middle type:
Standard reflection board: 200 mm 7.874 inch square area,
90% reflection rate.
- For long type:
Standard reflection board: 500 mm 19.685 inch square area,
90% reflection rate.

Notes: 1. Detecting an object within the maximum preset detection distance.

$$2. \text{Distance deviation} = \frac{a-b}{a} \times 100 (\%)$$

a: detection distance of detection target with reflectance of 90%.
b: detection distance of standard detection target with reflectance of 18%.

<Fig. 1>
[Brightness of sensor surface]

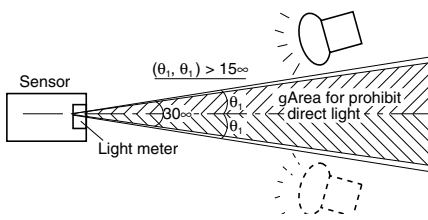

Note: Light from direct light sources (sunlight, strobe light, inverter illumination, reflected light from glass or mirrors etc.) that enters the sensor from within the prohibited range can cause the sensor to operate erroneously.

[Brightness of reflection surface]

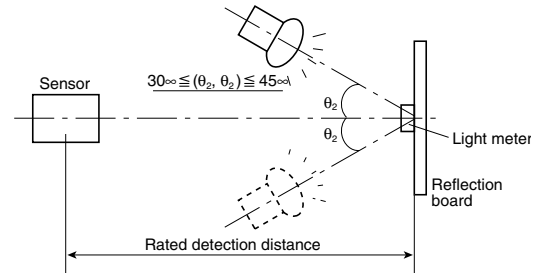

2. Absolute maximum rating (Measuring condition: ambient temp.: 25xC 77xF)

Items	Type	Built-in oscillation circuit type		External triggering type	
		5 V DC type	Free-ranging power type	5 V DC type	Free-ranging power type
Power supply voltage		-0.3 to 8 V DC	-0.3 to 30 V DC	-0.3 to 8 V DC	-0.3 to 30 V DC
Output dielectric strength		30 V		30 V	
Output flow current		100 mA		10 mA*	
Usable ambient temperature		-25 to +75xC +5 to +131xF (No freezing)		-25 to +75xC +5 to +131xF (No freezing)	
Storage temperature		-30 to +85xC -4 to +176xF		-30 to +85xC -4 to +176xF	

Note: * Thin short type is only: 100 mA

3. Electrical characteristics

(Measuring conditions: ambient temp.: 25xC 77xF; operating voltage: 5 V DC type =5V DC, free-ranging power type =24V DC)

1) Built-in oscillation circuit type

Items	Symbol	Thin short type*		Short type	Middle type	Long type	Measured conditions	
		NPN output type	PNP output type					
Rated operating voltage	Minimum	5V DC type: 4.5V/Free-ranging power type: 6.5V						
	Typical	—						
	Maximum	5V DC type: 6.5V/Free-ranging power type: 27V						
Average current consumption (Iout = 0 mA)	No detection	Minimum	—					
		Typical	4.5mA	5V DC type: 4.5mA/Free-ranging power type: 5.6mA				
		Maximum	6.2mA	5V DC type: 6.2mA/Free-ranging power type: 7.8mA				
	Detection	Minimum	—					
		Typical	7.0mA	11.0mA	5V DC type: 7.0mA/Free-ranging power type: 9.1mA			
		Maximum	11.2mA	15.2mA	5V DC type: 11.2mA/Free-ranging power type: 14.2mA			
Measuring cycle	Minimum	T	8ms/cycle					
Output characteristics	Remain voltage	Maximum	Vr	1 V DC	1.2 V DC	1 V DC	I _t = 100 mA	
	Leakage current	Maximum	I _l	5mA		3mA	V = 30V	

Note: * The thin short type is only available for 5V DC.

2) External triggering type (trigger conditions: trigger pulse width = 20ms and trigger synchronization = 5ms)

Items	Symbol	Thin short type Note 1		Short type	Middle type	Long type	Measured conditions	
		NPN output type	PNP output type					
Rated operating voltage	Minimum	5V DC type: 4.5V/Free-ranging type: 6.5V						
	Typical	—						
	Maximum	5V DC type: 6.5V/Free-ranging type: 27V						
Average current consumption	Without trigger input	Output OFF	Minimum	—			Note 2: *b	
			Typical	0.1m				
			Maximum	0.3m				
	Output ON	Minimum	—			Note 2: *d		
		Typical	2.6mA	6.7mA	5V DC type: 0.5mA/Free-ranging type: 1.4mA			
		Maximum	6.6mA	9.6mA	5V DC type: 3.4mA/Free-ranging type: 4.5mA			
	With trigger input	Output OFF	Minimum	—			Note 2: *a	
			Typical	2.2mA		5V DC type: 2.2mA/Free-ranging type: 3.1mA		
			Maximum	6.2mA		5V DC type: 6.2mA/Free-ranging type: 7.2mA		
Output ON		Minimum	—			Note 2: *c		
		Typical	4.2mA	6.2mA	5V DC type: 2.4mA/Free-ranging type: 3.3mA			
		Maximum	8.2mA	12.5mA	5V DC type: 8.2mA/Free-ranging type: 9.3mA			
Measuring cycle (Trigger interval)	Minimum	Tt	5ms/cycle					
External trigger	Pulse width	Minimum	20ms					
		Maximum	1/2Tt					
	Level	Maximum	V _{TL}	0.8V				
		Minimum	V _{TH}	3V				
Response performance: time from trigger pulse fall to detection output	Maximum	Tr	5ms					
Output characteristics	Remain voltage	Maximum	Vr	1 V DC	1.2 V DC	1 V	I = 10 mA	
	Leakage current	Maximum	II	5mA		3mA	V = 30 mA	

Notes: 1. The thin short type is only available for 5V DC.

2. The ratio between the 4 operating modes (*a to *d) depends on the external trigger period and detector time, and the current consumption corresponds with this varying ratio.

4. The output transistor is open collector. The output transistor is turned ON by the sensor detection status and turned OFF by its non-detection status.

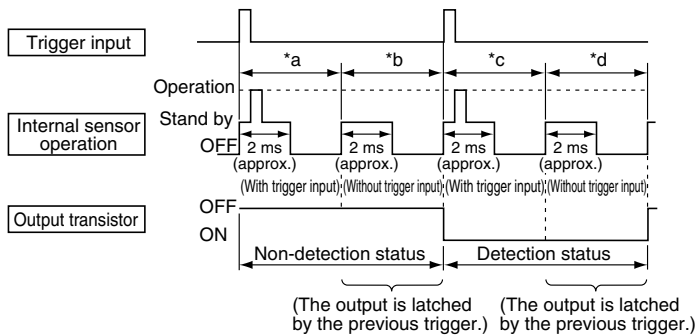

3. A high level is established in the open state due to pull-up by the internal circuit. (Refer to the connector wiring diagram.)

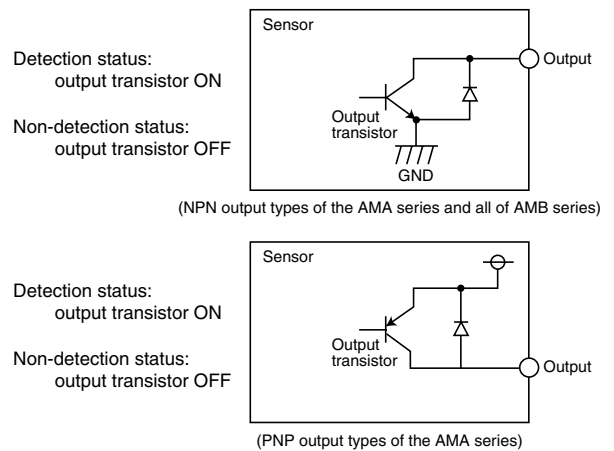

TIMING CHART

1. Built-in oscillation circuit type

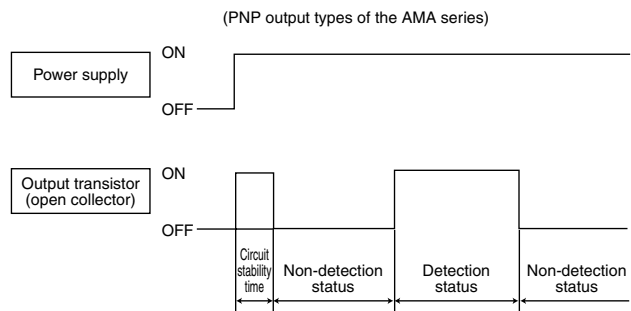
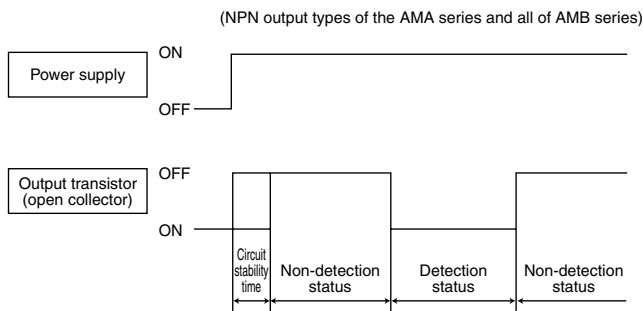

Notes: 1. Circuit stability time : Max. 12 ms

2. During the time taken for the circuit to stabilize after the power is turned on, the ON/OFF status of the output transistor is not determined by whether the sensor is in the detection status or non-detection status.

2. External triggering type

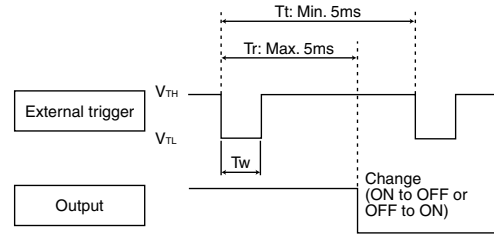
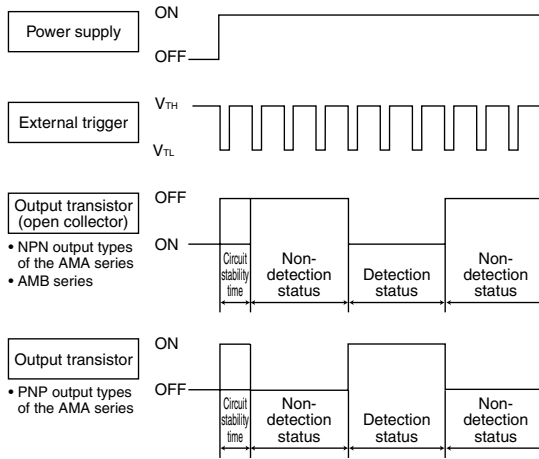

- Notes: 1. Circuit stability time : Max. 12 ms
 2. During the time taken for the circuit to stabilize after the power is turned on, the ON/OFF status of the output transistor is not determined by whether the sensor is in the detection status or non-detection status.

Note: The sensor recognizes at the V_{TH} / V_{TL} edge of an external trigger that the external trigger has been input.

HOW TO USE

• Wiring diagram of connector

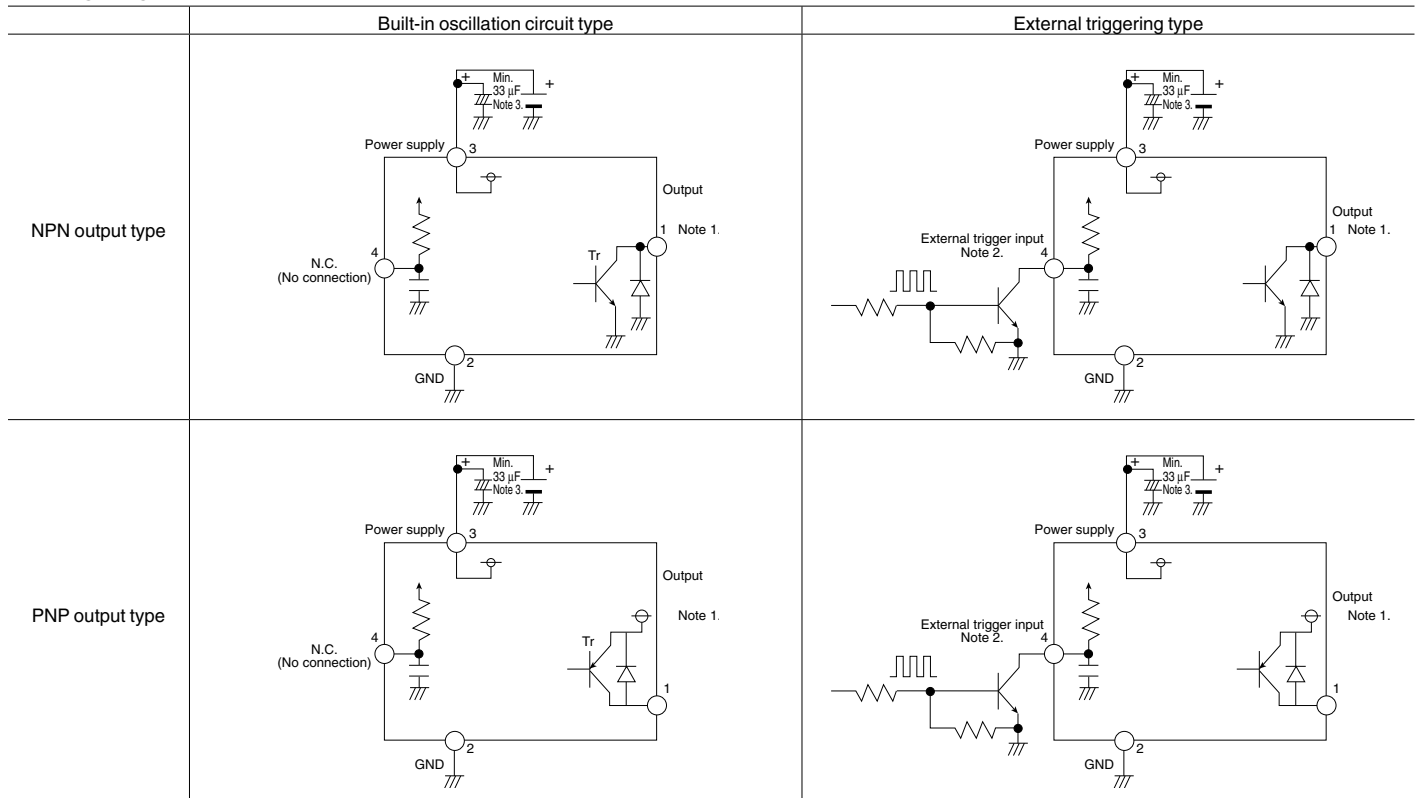

- Notes: 1. The output transistor has an open collector structure.
- Detection status: Output transistor ON (connected to GND)
 - Non-detection status: Output transistor OFF (open state)
2. The status of the external trigger input is as follows:
- Open at the high level
 - GND (less than 0.8V) at the low level
- Under no circumstances must a high-level voltage be applied.
3. To maintain the power supply noise performance, be certain to connect a capacitor (33mF or more) to the sensor power supply input terminal in order to stabilize the power supply voltage.

REFERENCE DATA

Operating region characteristics

- How to interpret the graph

Example: Operating area of the Short Type with rated detection distance of 8 cm 3.150 inch.

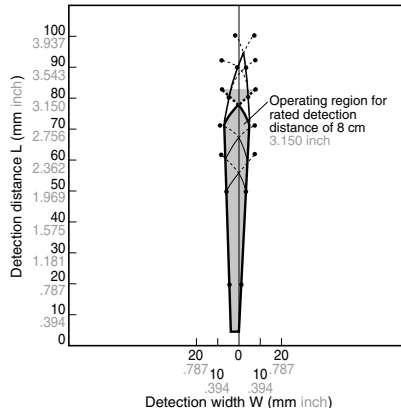

Operating area within the dotted lines

Objects that enter the entire area are detected.

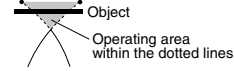

Note: If only part of the object is in the detection area, it is not detected.

Operating area within the solid lines

Objects that even partially enter the area are detected.

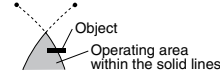

(1) Thin short type (AMA14MMMMM)
Short type (AMB14MMMMM)

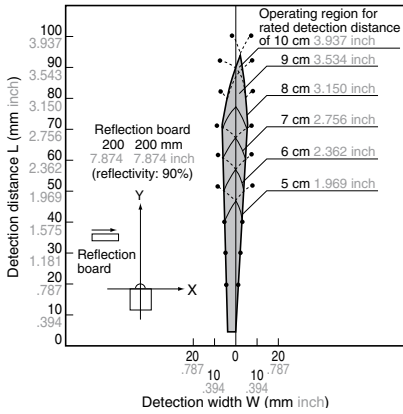

(2) Middle type (AMB24MMMMM)

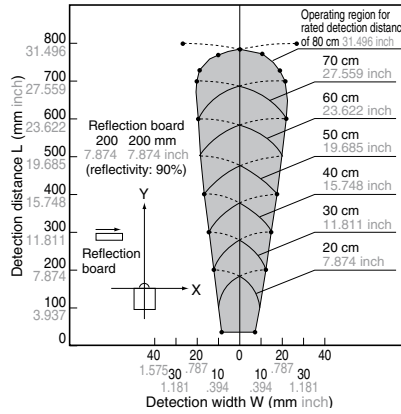

(3) Long type (AMB34MMMMM)

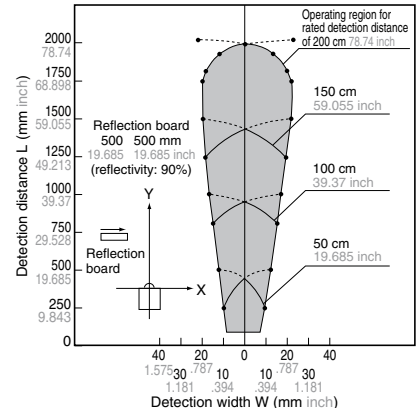

DIMENSIONS (Common to the Built-in oscillation circuit type and External triggering type)

mm inch

1) Thin short type (V)

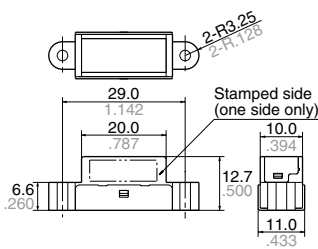

*Rear side connector protrusion: Max. 0.4mm

2) Short type (H)

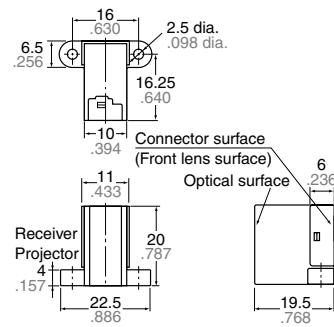

3) Middle type (H)

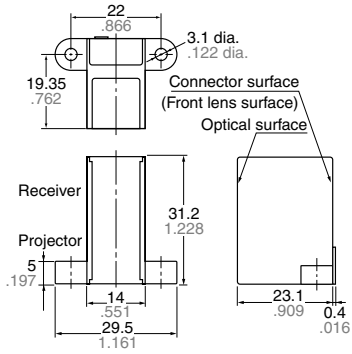

4) Long type (H)

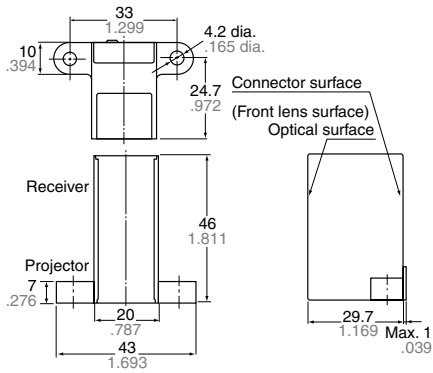

Long type (V)

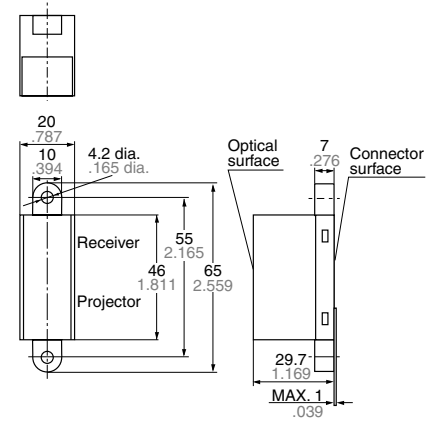

WIRING DIAGRAM (Connector surface view)

1) Thin short type (V)

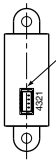

BM04B-SRSS
(J.S.T. Mfg. Co., Ltd.)
1: Output
2: GND
3: Power source
4: Built-in oscillation circuit type: N.C.
External triggering type:
external trigger input

2) Short type (H)

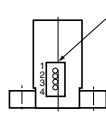

IL-Z-4P-S125L3-E
(Japan Aviation Electronics Industry, Limited)
1: Output
2: GND
3: Power source
4: Built-in oscillation circuit type: N.C.
External triggering type:
external trigger input

3) Middle type (H)

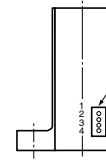

IL-Z-4P-S125T3-E
(Japan Aviation Electronics Industry, Limited)
1: Output
2: GND
3: Power source
4: Built-in oscillation circuit type: N.C.
External triggering type:
external trigger input

4) Long type (H)

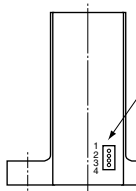

IL-Z-4P-S125T3-E
(Japan Aviation Electronics Industry, Limited)
1: Output
2: GND
3: Power source
4: Built-in oscillation circuit type: N.C.
External triggering type:
external trigger input

Long type (V)



IL-Z-4P-S125T3-E
(Japan Aviation Electronics Industry, Limited)
1: Output
2: GND
3: Power source
4: Built-in oscillation circuit type: N.C.
External triggering type:
external trigger input

Notes: Purchase the following connections:
1. Socket housing IL-Z-4S-S125C3
(Japan Aviation Electronic Industry, Ltd.)
2. Lead wire (with metal connector at one end)

OPTIONAL

mm inch

1. Connector with cable (for AMB series) AMV9001

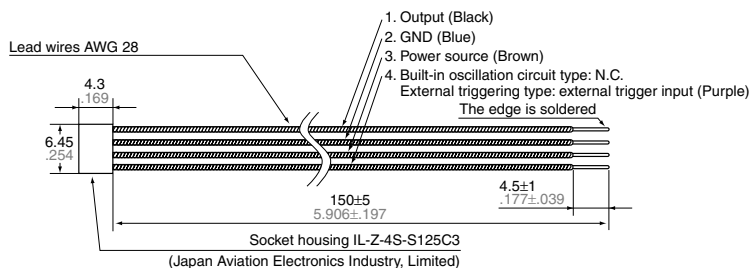

Note: Mistaken cable assembly can cause damage to the internal circuits, so please check the power cord before switching ON. (Particular care must be taken as to avoid reverse connection of the power.)

2. Connector with cable (for AMA series) AMV9002

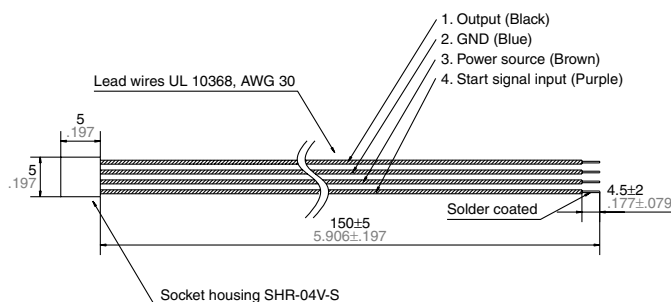

NOTES

1. Environment

- 1) Avoid using the sensor in environments containing excessive amounts of steam, dust, corrosive gas, or where organic solvents are present.
- 2) When the sensor is used in noisy environments, connect a capacitor (minimum 33 μ F) across its power input terminals.

2. Wiring

- 1) Check all wiring before applying power. Incorrect wiring may damage the internal circuit (in particular, check that the connection to the power supply is not reversed.)
- 2) Avoid excessive removing and replacing of the connector.

3. Detector surface (Optical surface)

- 1) Keep the detector surface clean. Excessive dust or dirt on the detector surface will deteriorate the sensing performance.
- 2) Do not allow condensation or freezing to occur on the surface of the sensor. If condensation or freezing does occur at low temperatures, the sensor may not detect objects correctly.

3) This product is designed to detect the existence of human body. The sensor will not detect objects consisting of a low reflective material (e.g., an object coated with black rubber, etc.) or of a highly reflective material (e.g., mirror, glass, coated paper, etc.)

4) The front surface of the lens and case are made of polycarbonate resin and can withstand water, alcohol, oils, salts and weak acids. Other fluids such as alkalines, aromatic hydrocarbons and halogenated hydrocarbons may melt or swell the lens and case, please do not have such fluids touch the lens and case.

5) If you use the sensor with a cover or filter connected to the front of the sensor, the sensor may detect the cover itself, the detection distance can change, and unstable operation can result.

6) When multiple sensors are to be used side by side, please verify that there will be no mutual interference by installing them with the proper spacing, depending on the type as shown below.

Model number	Sensor spacing
AMB1 series	5 cm 1.969 inch
AMA1 series	8 cm 3.150 inch
AMB2 series	10 cm 3.937 inch
AMB3 series	20 cm 7.874 inch

7) To protect the inner circuit, wiring should be max. 3 m 9.843 ft..

4. Recommended installation procedure

Install the photoelectric sensor so that it is orientated correctly in relation to the pass directions of the target objects as shown in the figure below.

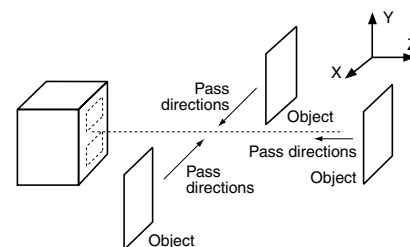

* → stands for pass direction of the target object.

For the general precautions, refer to the Notes for Motion Sensors on next page.