

阅读申明

- 1.本站收集的数据手册和产品资料都来自互联网，版权归原作者所有。如读者和版权方有任何异议请及时告之，我们将妥善解决。
- 2.本站提供的中文数据手册是英文数据手册的中文翻译，其目的是协助用户阅读，该译文无法自动跟随原稿更新，同时也可能存在翻译上的不当。建议读者以英文原稿为参考以便获得更精准的信息。
- 3.本站提供的产品资料，来自厂商的技术支持或者使用者的心得体会等，其内容可能存在描述上的差异，建议读者做出适当判断。
- 4.如需与我们联系，请发邮件到marketing@iczoom.com，主题请标有“数据手册”字样。

Read Statement

1. The datasheets and other product information on the site are all from network reference or other public materials, and the copyright belongs to the original author and original published source. If readers and copyright owners have any objections, please contact us and we will deal with it in a timely manner.
2. The Chinese datasheets provided on the website is a Chinese translation of the English datasheets. Its purpose is for reader's learning exchange only and do not involve commercial purposes. The translation cannot be automatically updated with the original manuscript, and there may also be improper translations. Readers are advised to use the English manuscript as a reference for more accurate information.
3. All product information provided on the website refer to solutions from manufacturers' technical support or users the contents may have differences in description, and readers are advised to take the original article as the standard.
4. If you have any questions, please contact us at marketing@iczoom.com and mark the subject with "Datasheets" .

Slim Rectangular Inductive Prox



TL-T

Miniature, Slim-styled Type Proximity

- Space-saving prox ideal for timing cam and dog detection
- Four mounting holes provided: two from the side and two from the rear of the housing
- Ganged mounting possible for multiple pulse generation
- Alternate frequency models available to avoid mutual interference



Ordering Information

Type	Sensing Distance	Part number					
		DC 3-wire switching type				AC switching type	
		NPN-NO	NPN-NC	PNP-NO	PNP-NC	SCR-NO	SCR-NC
Shielded 	2 mm (0.08 in)	TL-T2E1	TL-T2E2	TL-T2F1	TL-T2F2	TL-T2Y1	TL-T2Y2
Unshielded 	5 mm (0.20 in)	TL-T5ME1	TL-T5ME2	TL-T5MF1	TL-T5MF2	TL-T5MY1	TL-T5MY2

- Note: 1. To avoid mutual interference, this sensor can be ordered with a different oscillating frequency. Add a "5" to the end of the part number (e.g. TL-N2E15).
2. Add suffix "G" to the model number when placing your order for European models with color-coded cables conforming to CENELEC standard (EN50044). Refer to the color code table in the "Output Stage Circuit Diagram" for the cable color codes of the European models.

Specifications

■ RATINGS/CHARACTERISTICS

Part number		TL-T2E1, TL-T2E2, TL-T2F1, TL-T2F2	TL-T2Y1, TL-T2Y2	TL-T5ME1, TL-T5ME2, TL-T5MF1, TL-T5MF2	TL-T5MY1, TL-T5MY2
Supply voltage (operating voltage range)		E and F models: 12 to 24 VDC (10 to 30 VDC), ripple (p-p): 20% max. Y models: 100 to 220 VAC (90 to 250 VAC), 50/60 Hz			
Current consumption		E and F models: 15 mA max. at 24 VDC			
Leakage current		Y models: 2.5 mA max. at 200 VAC			
Sensing object		Magnetic metal (The sensing distance decreases with non-magnetic metal.)			
Sensing distance		2 mm \pm 10% (0.08 \pm 10%)		5 mm \pm 10% (0.19 \pm 10%)	
Sensing distance (standard object)		0 to 1.6 mm (iron, 12 x 12 x 1 mm) 0 to 0.06 in (iron 0.47, 47 x 0.04 in)		0 to 4 mm (iron, 15 x 15 x 1 mm) 0 to 0.157 in (iron 0.59 x 0.59 x 0.39 in)	
Differential travel		10% max. of sensing distance			
Response frequency		E and F models: 800 Hz, Y models: 20 Hz		E and F models: 250 Hz, Y models: 20 Hz	
Operating status (with sensing object approaching)		E1 models: L output signal with load ON E2 models: H output signal with load OFF F1 models: H output signal with load ON Y1 models: Load ON Y2 models: Load OFF			
Control output	Type	E1: NPN-NO Y1: SCR-NO E2: NPN-NC Y2: SCR-NC F1: PNP-NO F2: PNP-NC			
	Switching capacity	E and F models: 100 mA max. at 12 VDC and 200 mA max. at 24 VDC Y models: 10 to 200 mA			
Circuit protection		E and F models: Reverse connection protection and surge absorber Y models: Surge absorber			
Indicator		Operation indicator (red LED)			
Ambient temperature	Operating	-25°C to 70°C (-13°F to 158°F) with no icing			
Ambient humidity	Operating	35% to 95%			
Temperature influence		\pm 10% max. of sensing distance at 23°C (73.4°F) in the temperature range of -25°C to 70°C (-13°F to 158°F)			
Voltage influence		E and F models: \pm 2.5% max. of sensing distance within a range of \pm 15% of the rated power supply voltage Y models: \pm 2.5% max. of sensing distance within a range of \pm 10% of the rated power supply voltage			
Residual voltage		E and F models: 1.0 V max. with a load current of 100 mA and a cord length of 2 m Y models: Refer to <i>Residual Load Voltage (Typical)</i> on page 4.			
Insulation resistance		50 M Ω min. (at 500 VDC) between case and current carry parts			
Dielectric strength		DC switching models: 1,000 VAC, 50/60 Hz for 1 min between case and current carry parts AC switching models: 2,000 VAC, 50/60 Hz for 1 min between case and current carry parts			
Vibration resistance		10 to 55 Hz, 1.5-mm (0.06 in) double amplitude for 2 hours each in X, Y, and Z directions			
Shock resistance		500 m/s ² (1640 ft/s ²) approx. 50G for 10 times each in X, Y, and Z directions			
Enclosure rating		IEC IP67			
Weight (with 2-m cord)		Approx. 70 g (2.47 oz)			
Material	Case	Heat-resistant ABS resin			
	Sensing surface	Heat-resistant ABS resin			

Operation

OUTPUT CIRCUITS

E Models

NPN (DC 3-wire)

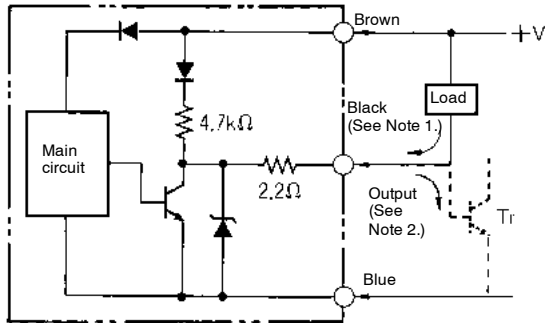

- Note: 1. 200 mA max. (load current)
 2. When a transistor is connected

F Models

PNP (DC 3-wire)

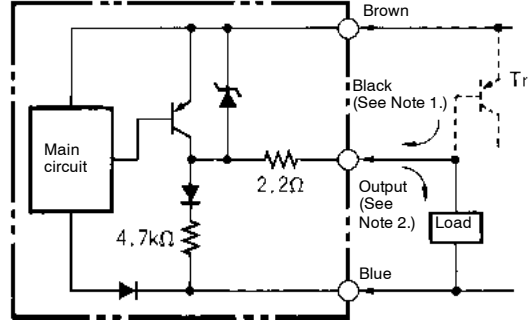

- Note: 1. 200 mA max. (load current)
 2. When a transistor is connected

Y Models

(AC 2-wire)

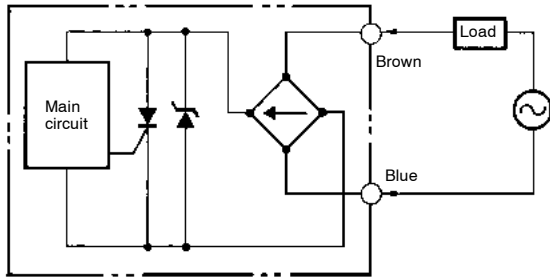

TIMING CHARTS

E Models

NPN (DC 3-wire)

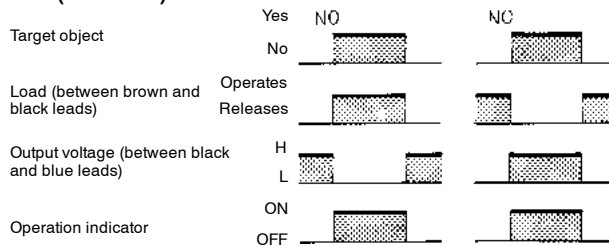

F Models

PNP (DC 3-wire)

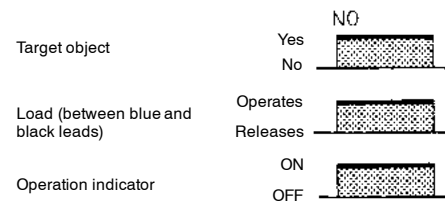

Y Models

(DC 2-wire)

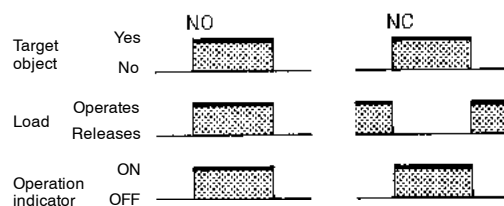

Engineering Data

OPERATING RANGE (TYPICAL)

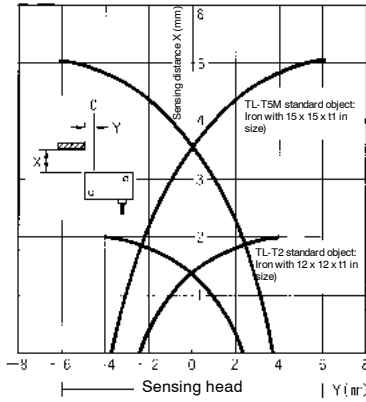

SENSING OBJECT SIZE AND MATERIAL VS. SENSING DISTANCE (TYPICAL)

TL-T2

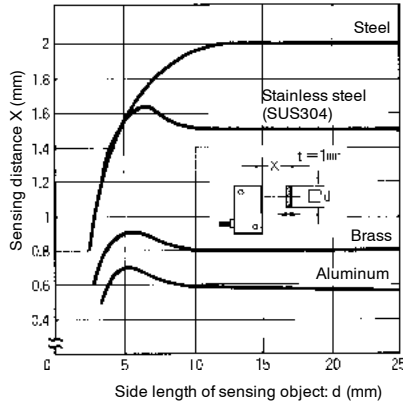

TL-T5M

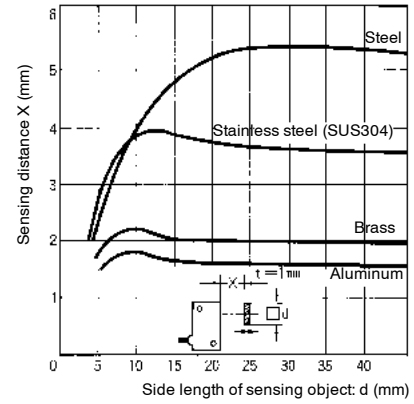

LEAKAGE CURRENT (TYPICAL)

TL-T□Y

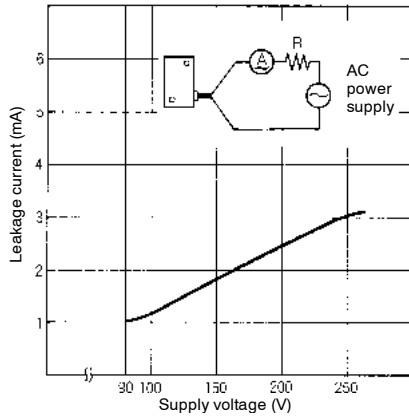

RESIDUAL LOAD VOLTAGE (TYPICAL)

(at constant 100 VAC)

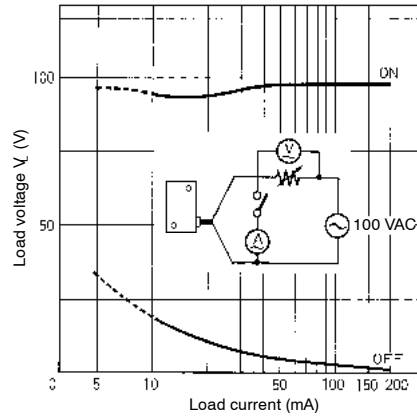

(at constant 200 VAC)

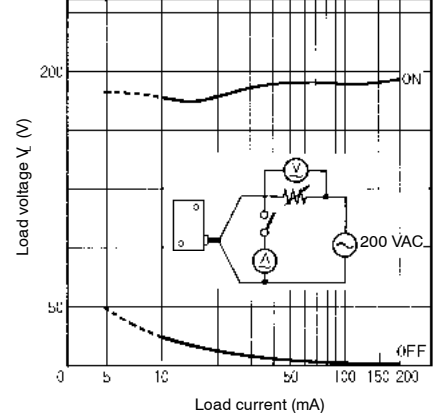

Dimensions

Unit: mm (inch)

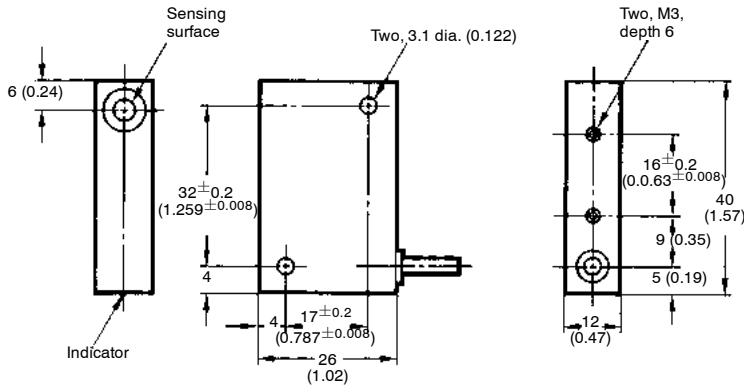

DC switching model: Three, 0.2-mm (0.007 in) conductors
 AC switching model: Two, 0.3-mm (0.012 in) conductors
 Oil- and vibration-resistant, vinyl-insulated round cord,
 4 external dia.; standard length: 2 m (6.56 ft)

Precautions

CONNECTION TO THE LOAD

Be sure to connect the Proximity Sensor to the power source through a load. Direct connection of the Sensor may damage the Sensor.

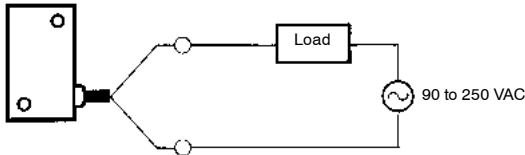

MOUNTING

At the time of rear mounting, be sure that the tightening torque does not exceed 6 kgf • cm (0.59 N • m) 5.22 in • lbf.

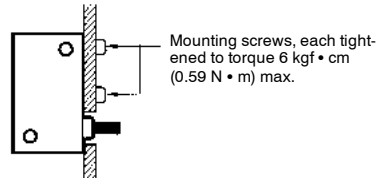

At the time of side mounting, be sure that the tightening torque does not exceed 8 kgf • cm (0.78 N • m) 2.02 in • lbf.

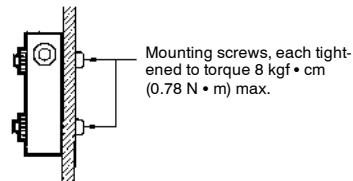

EFFECT OF SURROUNDING METALS

If the TL-T5M is embedded in metal, keep at least the following distances between the TL-T and the metal.

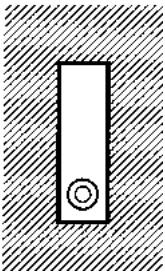
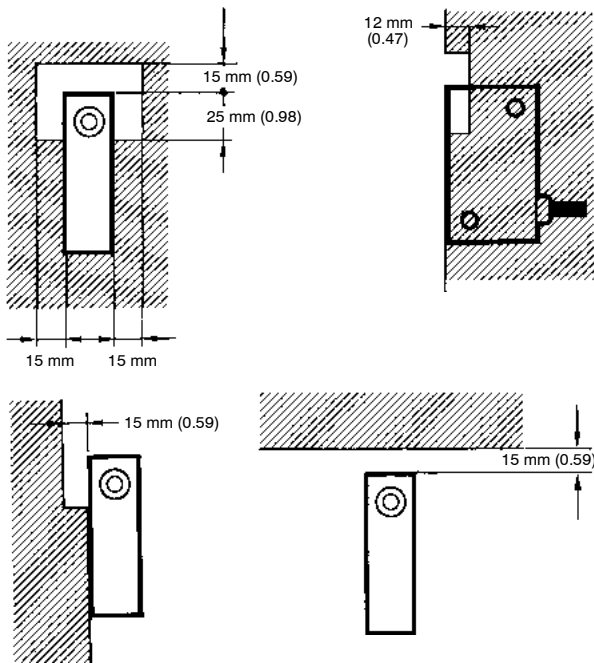

If the TL-T2 is embedded in metal, the TL-T2 will not be influenced by metal.

MUTUAL INTERFERENCE

When two or more TL-T sensors are mounted face-to-face or side-by-side, separate them as shown below. The table below indicates the minimum distances A and B.

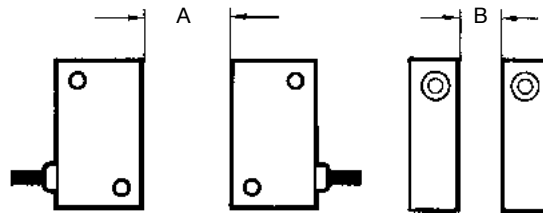

Distance	A	B
TL-T5□□	120 mm (4.72 in)	80 mm (3.15 in)
TL-T5□□5	60 mm (2.36 in)	40 mm (1.57 in)
TL-T2□□	40 mm (1.57 in)	12 mm (0.47 in)
TL-T2□□5	10 mm (0.39 in)	0 mm

Note: Figures in parentheses will apply if the Sensors in use are different from each other in response frequency.

NOTE: DIMENSIONS SHOWN ARE IN MILLIMETERS. To convert millimeters to inches divide by 25.4.

OMRON[®]
OMRON ELECTRONICS LLC
 One East Commerce Drive
 Schaumburg, IL 60173
1-800-55-OMRON

OMRON ON-LINE
 Global - <http://www.omron.com>
 USA - <http://www.omron.com/oei>
 Canada - <http://www.omron.com/oci>

OMRON CANADA, INC.
 885 Milner Avenue
 Scarborough, Ontario M1B 5V8
416-286-6465