

阅读申明

- 1.本站收集的数据手册和产品资料都来自互联网，版权归原作者所有。如读者和版权方有任何异议请及时告之，我们将妥善解决。
- 2.本站提供的中文数据手册是英文数据手册的中文翻译，其目的是协助用户阅读，该译文无法自动跟随原稿更新，同时也可能存在翻译上的不当。建议读者以英文原稿为参考以便获得更精准的信息。
- 3.本站提供的产品资料，来自厂商的技术支持或者使用者的心得体会等，其内容可能存在描述上的差异，建议读者做出适当判断。
- 4.如需与我们联系，请发邮件到marketing@iczoom.com，主题请标有“数据手册”字样。

Read Statement

1. The datasheets and other product information on the site are all from network reference or other public materials, and the copyright belongs to the original author and original published source. If readers and copyright owners have any objections, please contact us and we will deal with it in a timely manner.
2. The Chinese datasheets provided on the website is a Chinese translation of the English datasheets. Its purpose is for reader's learning exchange only and do not involve commercial purposes. The translation cannot be automatically updated with the original manuscript, and there may also be improper translations. Readers are advised to use the English manuscript as a reference for more accurate information.
3. All product information provided on the website refer to solutions from manufacturers' technical support or users the contents may have differences in description, and readers are advised to take the original article as the standard.
4. If you have any questions, please contact us at marketing@iczoom.com and mark the subject with "Datasheets" .

Temperature measuring transducer - MCR-T-UI-E - 2814113

Please be informed that the data shown in this PDF Document is generated from our Online Catalog. Please find the complete data in the user's documentation. Our General Terms of Use for Downloads are valid (<http://phoenixcontact.com/download>)



MCR-T module, programmable temperature measuring transducer, configured, for thermocouple sensors and resistance thermometers, with 2, 3, or 4-wire system, with electrical isolation between input/output and input/auxiliary power

Product Features

- Freely programmable via MCR/PI-CONF-WIN
- With transistor switching output
- Measure differential temperatures
- Inverse output signal ranges as an option
- For resistance thermometers and thermocouples



Key Commercial Data

Packing unit	1 pc
GTIN	 4 017918 139438
Weight per Piece (excluding packing)	145.3 g
Custom tariff number	85437090
Country of origin	Germany

Technical data

Note

Utilization restriction	EMC: class A product, see manufacturer's declaration in the download area
-------------------------	---

Dimensions

Width	17.5 mm
Height	99 mm
Depth	114.5 mm

Temperature measuring transducer - MCR-T-UI-E - 2814113

Technical data

Ambient conditions

Ambient temperature (operation)	-20 °C ... 65 °C
---------------------------------	------------------

Input data

Configurable/programmable	Yes, preconfigured
Sensor types (RTD) that can be used	Pt, Ni, Cu sensors
Sensor types that can be used (TC)	U, T, L, J, E, K, N, S, R, B, C, W, HK
Linear resistance measuring range	0 Ω ... 8000 Ω (freely adjustable, min. measuring range 100 Ω)
Sensor input current	250 μA (resistance thermometer)
Temperature measuring range	Depending on sensor type used
Connection method	2, 3, 4-wire
Protective circuit	Transient protection
	Surge protection 30 V DC
Connection method	Pluggable screw connection

Output data

Output name	Voltage output / current output
Configurable/programmable	Yes, preconfigured
Voltage output signal	0 V ... 10 V
	0 V ... 5 V
	-5 V ... 5 V
	-10 V ... 10 V
	10 V ... 0 V
	5 V ... 0 V
	10 V ... -10 V
	5 V ... -5 V
	1 V ... 5 V
Current output signal	0 mA ... 20 mA
	4 mA ... 20 mA
	20 mA ... 0 mA
	20 mA ... 4 mA
Max. output voltage	± 12 V
Max. output current	24 mA
Output voltage range with wire break	-12 V ... 12 V
Output current range with wire break	0 A ... 24 mA
Output voltage range with overrange/underrange	-12 V ... 12 V
Output current range with overrange/underrange	0 A ... 24 mA
Load/output load voltage output	≥ 10 kΩ
Load/output load current output	≤ 500 Ω

Temperature measuring transducer - MCR-T-UI-E - 2814113

Technical data

Output data

Protective circuit	Transient protection
D/A resolution	± 12 bit

Switching output

Output name	Transistor output, pnp
Output description	Can carry a load of 100 mA, switches supply voltage (not protected against short-circuit); locked in case of order-specific configuration, otherwise freely programmable through MCR/PI-CONF-WIN
Output voltage range	18 V DC ... 30 V DC (switches supply voltage, not short-circuit resistant)
Continuous load current	100 mA

Power supply

Supply voltage range	18 V DC ... 30 V DC
Max. current consumption	≤ 60 mA
Typical current consumption	40 mA

Connection data

Connection method	Pluggable screw connection
Conductor cross section solid min.	0.2 mm ²
Conductor cross section solid max.	2.5 mm ²
Conductor cross section AWG min.	24
Conductor cross section AWG max.	14
Conductor cross section flexible min.	0.2 mm ²
Conductor cross section flexible max.	2.5 mm ²
Stripping length	8 mm
Screw thread	M3

General

Maximum transmission error	≤ 0.1 % (of maximum range, ±6 mV or ±12 µA at output)
Maximum temperature coefficient	≤ 0.01 %/K
Temperature coefficient, typical	0.005 %/K
Cold point error, max.	≤ 3 K
Typical cold point errors	1.5 K
Test voltage input/output	1 kV (50 Hz, 1 min.)
Test voltage input/power supply	1 kV (50 Hz, 1 min.)
Color	green
Housing material	Polyamide PA non-reinforced
Mounting position	any
Conformance	CE-compliant
UL, USA / Canada	Class I, Div. 2, Groups A, B, C, D or Non-Hazardous Locations

Temperature measuring transducer - MCR-T-UI-E - 2814113

Technical data

General

GL	Germanischer Lloyd
----	--------------------

Standards and Regulations

Connection in acc. with standard	CUL
Conformance	CE-compliant
UL, USA / Canada	Class I, Div. 2, Groups A, B, C, D or Non-Hazardous Locations
GL	Germanischer Lloyd

Classifications

eCl@ss

eCl@ss 4.0	27200206
eCl@ss 4.1	27200206
eCl@ss 5.0	27200206
eCl@ss 5.1	27200206
eCl@ss 6.0	27200206
eCl@ss 7.0	27200206
eCl@ss 8.0	27371503

ETIM

ETIM 2.0	EC001446
ETIM 3.0	EC001446
ETIM 4.0	EC001446
ETIM 5.0	EC002568

UNSPSC

UNSPSC 6.01	30211506
UNSPSC 7.0901	39121008
UNSPSC 11	39121008
UNSPSC 12.01	39121008
UNSPSC 13.2	39121008

Approvals

Approvals

Approvals

UL Recognized / cUL Recognized / GL / EAC / cULus Recognized

Temperature measuring transducer - MCR-T-UI-E - 2814113

Approvals

Ex Approvals

UL Listed / cUL Listed / cULus Listed

Approvals submitted

Approval details

UL Recognized

cUL Recognized

GL

EAC

cULus Recognized

Drawings

Dimensional drawing

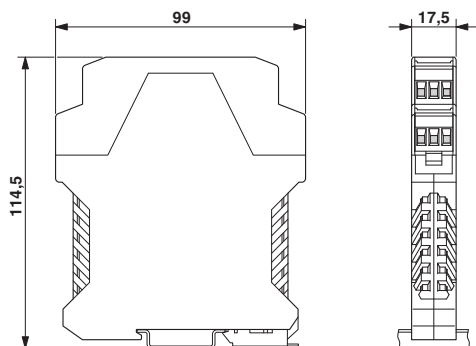

Circuit diagram

