

## 阅读申明

- 1.本站收集的数据手册和产品资料都来自互联网，版权归原作者所有。如读者和版权方有任何异议请及时告之，我们将妥善解决。
- 2.本站提供的中文数据手册是英文数据手册的中文翻译，其目的是协助用户阅读，该译文无法自动跟随原稿更新，同时也可能存在翻译上的不当。建议读者以英文原稿为参考以便获得更精准的信息。
- 3.本站提供的产品资料，来自厂商的技术支持或者使用者的心得体会等，其内容可能存在描述上的差异，建议读者做出适当判断。
- 4.如需与我们联系，请发邮件到marketing@iczoom.com，主题请标有“数据手册”字样。

## Read Statement

1. The datasheets and other product information on the site are all from network reference or other public materials, and the copyright belongs to the original author and original published source. If readers and copyright owners have any objections, please contact us and we will deal with it in a timely manner.
2. The Chinese datasheets provided on the website is a Chinese translation of the English datasheets. Its purpose is for reader's learning exchange only and do not involve commercial purposes. The translation cannot be automatically updated with the original manuscript, and there may also be improper translations. Readers are advised to use the English manuscript as a reference for more accurate information.
3. All product information provided on the website refer to solutions from manufacturers' technical support or users the contents may have differences in description, and readers are advised to take the original article as the standard.
4. If you have any questions, please contact us at marketing@iczoom.com and mark the subject with "Datasheets" .

# ISDN S-INTERFACE LOW PROFILE DUAL SMT TRANSFORMERS

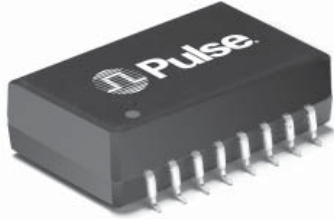

- RoHS peak reflow temperature rating 245°C
- Meets pulse waveform template of CCITT I.430 when recommended transformer and chip pair are used
- Excellent longitudinal balance
- 2 KVRms isolation voltage
- Available in Tape & Reel or tube packaging
- UL recognized

## Electrical Specifications @ 25°C — Operating Temperature 0°C to 70°C

RoHS Compliant Part Number	Ratio <sup>A</sup> (±2%)		OCL Pri (mH MIN)	L <sub>L</sub> Sec (μH MAX)		CW/W (pF MAX)	CD Pri <sup>B</sup> (pF MAX)		DCR Pri (Ω ±25%)		DCR Sec (W ±25%)		D <sub>Ibc</sub> <sup>C</sup> (mA MAX)
	A	B	A & B	A	B	A & B	A	B	A	B	A	B	
T5005NL	1:2.5	1:2.5	22	40	40	100	110	110	2.4	2.4	5.3	5.3	1
T5007NL	1:2	1:2	22	5	5	100	80	80	2.4	2.4	4.2	4.2	1
T5008NL	1:1	1:1	22	5	5	100	42	42	2.4	2.4	2.4	2.4	1
T5010NL	1:1.8	1:1.8	22	15	15	100	160	160	2.4	2.4	3.8	3.8	1

U.S. Patent No. 5,015,981Z

- A. A center-tapped** winding can be created by connecting two ends of a split center winding together on the printed circuit board. In ISDN-S applications, the primary winding is the line side transformer winding.
- B. Minimum primary** inductance and maximum distributed capacitance satisfy the transmitter output and receiver input impedance requirements of CCITT I.430 for both the TE and the NT. The maximum distributed capacitance allows sufficient margin for the capacitance of the IC and a protection diode network. It is consistent with the overall maximum value specified and the permitted length of the basic access TE cord.
- C. The maximum** specified unbalanced DC current capability is based on 20 mH minimum primary OCL.

See next page for detailed packaging information.

## Mechanical

### TSJ

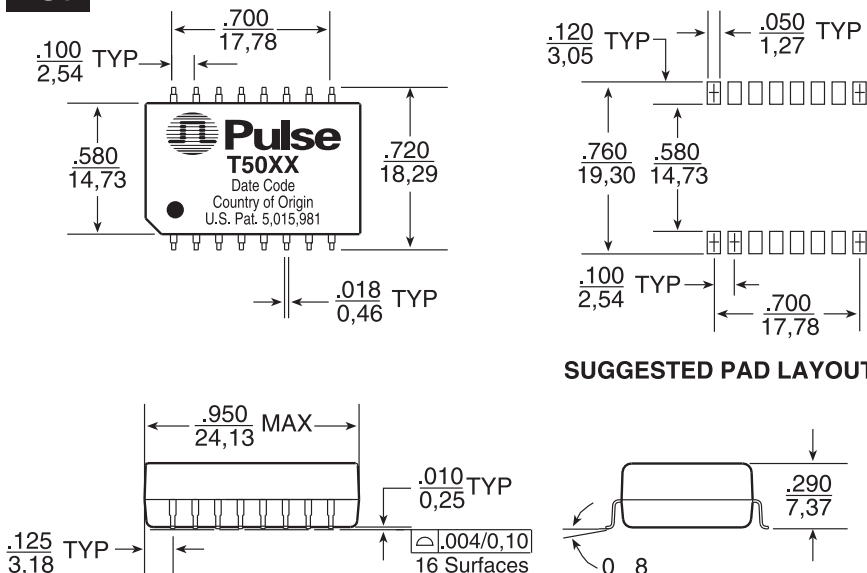

### SUGGESTED PAD LAYOUT

## Schematic

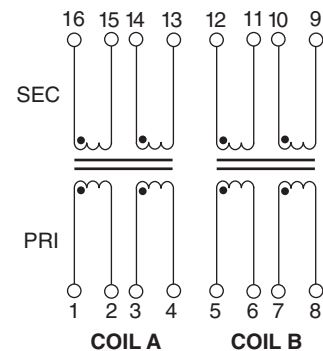

Dimensions:  $\frac{\text{Inches}}{\text{mm}}$   
Unless otherwise specified all tolerances are  $\pm .010$   
 $0,25$

# ISDN S-INTERFACE LOW PROFILE DUAL SMT TRANSFORMERS



IC Manufacturer	IC Part Number	Dual Surface Mount
<b>TX &amp; RX</b>		
<b>AT&amp;T/Lucent</b>	T7250/7256/7259	T5005NL
<b>Mietec</b>	T7903 MTC-2072	T5007NL T5007NL
<b>Mitel</b>	MT8930	T5007NL
<b>Motorola</b>	MC145474/145475 MC145574	T5008NL T5005NL
<b>National*</b>	TP3420/3421	T5007NL
<b>SGS Thomson</b>	ST5420, ST5421	T5007NL
<b>Siemens</b>	PEB 2080/2081/2085 PSB 2186 PEB 2084/2086	T5007NL
<b>Yamaha</b>	7405B, YTD421	T5007NL
<b>B</b>	29C53	T5010NL

\*NOTE: National recommends a 1:2 receive transformer, but used as a 1:1 ratio by connecting only half the secondary winding.

## Application Notes

**1. General Information** – The S-interface is the standardized four-wire digital telephone access point defined by the CCITT I-series recommendations for the Integrated Services Digital Network. This “basic rate access” accommodates two 64 Kbps “B-channels” for information, one 16Kbps “D-channel” intended for signaling and control, and 48Kbps for framing and other purposes, giving a total rate of 192Kbps. The CCITT physical layer recommends that the user network interface be transformer coupled.

The transformer provides isolation for the line card or the terminal from the line. It is also a way to provide phantom power feeding to the terminal over the S-loop. Each end requires a transmit and a receive transformer. Chokes are used in some applications to reduce common mode noise.

Transformers described in this data sheet are matched to the transceivers offered by the IC manufacturers listed.

## Common Mode Chokes

Refer to data sheet G002 for selection of low and high frequency common mode chokes.

## For More Information:

### Pulse Worldwide Headquarters

12220 World Trade Dr.  
San Diego, CA 92128  
U.S.A.

[www.pulseeng.com](http://www.pulseeng.com)

Tel: 858 674 8100  
Fax: 858 674 8262

### Pulse Europe

Einsteinstrasse 1  
D-71083 Herrenberg  
Germany

Tel: 49 7032 7806 0  
Fax: 49 7032 7806 135

### Pulse China Headquarters

B402, Shenzhen Academy of  
Aerospace Technology Bldg.  
10th Kejinan Rd.  
High-Tech Zone  
Nanshan District  
Shenzhen, PR China 518057

Tel: 86 755 33966678  
Fax: 86 755 33966700

### Pulse North China

Room 2704/2705  
Super Ocean Finance Ctr.  
2067 Yan An Rd. West  
Shanghai 200336  
China

Tel: 86 21 62787060  
Fax: 86 2162786973

### Pulse South Asia

135 Joo Seng Rd.  
#03-02  
PM Industrial Bldg.  
Singapore 368363

Tel: 65 6287 8998  
Fax: 65 6287 8998

### Pulse North Asia

3F, No. 198  
Zhongyuan Rd.  
Zhongli City  
Taoyuan County 320  
Taiwan R. O. C.

Tel: 886 3 4356768  
Fax: FRE 886 3 4356820  
Pulse: 886 3 4356823

Performance warranty of products offered on this data sheet is limited to the parameters specified. Data is subject to change without notice. Other brand and product names mentioned herein may be trademarks or registered trademarks of their respective owners.

© Copyright, 2009. Pulse Engineering, Inc. All rights reserved.

[www.pulseeng.com](http://www.pulseeng.com)

Packaging Information	
Type	SMT
Part Weight	7 grams
Parts/Tube	20
Parts/Tray*	50
Parts/Reel*	200
Reel Diameter	13 inches
Tape Width	44 mm
Pitch	24 mm

\*NOTE: Standard packaging for all transformers on this data sheet is anti-static tubes. Optional Tape & Reel packaging can be ordered by adding a “T” suffix to the end of the part number, (i.e: T5005NLT).