

阅读申明

- 1.本站收集的数据手册和产品资料都来自互联网，版权归原作者所有。如读者和版权方有任何异议请及时告之，我们将妥善解决。
- 2.本站提供的中文数据手册是英文数据手册的中文翻译，其目的是协助用户阅读，该译文无法自动跟随原稿更新，同时也可能存在翻译上的不当。建议读者以英文原稿为参考以便获得更精准的信息。
- 3.本站提供的产品资料，来自厂商的技术支持或者使用者的心得体会等，其内容可能存在描述上的差异，建议读者做出适当判断。
- 4.如需与我们联系，请发邮件到marketing@iczoom.com，主题请标有“数据手册”字样。

Read Statement

1. The datasheets and other product information on the site are all from network reference or other public materials, and the copyright belongs to the original author and original published source. If readers and copyright owners have any objections, please contact us and we will deal with it in a timely manner.
2. The Chinese datasheets provided on the website is a Chinese translation of the English datasheets. Its purpose is for reader's learning exchange only and do not involve commercial purposes. The translation cannot be automatically updated with the original manuscript, and there may also be improper translations. Readers are advised to use the English manuscript as a reference for more accurate information.
3. All product information provided on the website refer to solutions from manufacturers' technical support or users the contents may have differences in description, and readers are advised to take the original article as the standard.
4. If you have any questions, please contact us at marketing@iczoom.com and mark the subject with "Datasheets" .

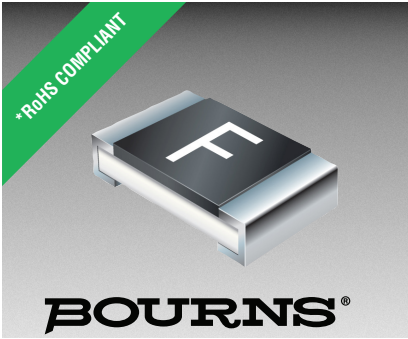

SinglFuse™ SF-1206F Series Features

- Single blow fuse for overcurrent protection
- 3216 (EIA 1206) miniature footprint
- Fast acting fuse
- UL listed
- RoHS compliant* and halogen free**
- Thin film chip fuse
- Surface mount packaging for automated assembly

SF-1206F Series - Fast Acting Surface Mount Fuses

Electrical Characteristics

Model	Rated Current (Amps)	Fusing Time	Resistance (mΩ) Typ.***	Rated Voltage	Breaking Capacity	Typical I ² t (A ² s)****
SF-1206F050	0.50	Open within 1 min. at 200 % rated current	590	DC 63 V	DC 63 V 50 A	0.011
SF-1206F080	0.80		225			0.031
SF-1206F100	1.00		130			0.034
SF-1206F125	1.25		88			0.062
SF-1206F150	1.50		65			0.144
SF-1206F200	2.00		38	DC 32 V	DC 32 V 50 A	0.181
SF-1206F250	2.50		32			0.351
SF-1206F300	3.00		23	DC 24 V	DC 24 V 50 A	0.501
SF-1206F400	4.00		15			0.954
SF-1206F500	5.00		11			0.966
SF-1206F700	7.00	7			3.25	

*** Resistance value was measured with less than 10 % of rated current.

****Typical I²t value is measured at 10x rated current.

Reliability Testing

Parameter	Requirement	Test Method
Carrying Capacity	No fusing	Rated current, 4 hours
Fusing Time	Within 1 minute	200 % of its rated current
Interrupting Ability	No mechanical damages	After the fuse is interrupted, rated voltage applied for 30 seconds again
Bending Test	No mechanical damages	Distance between holding points: 90 mm, Bending: 3 mm, 1time, 30 seconds
Resistance to Solder Heat	±20 %	260 °C ±5 °C, 10 seconds ±1 second
Solderability	95 % coverage minimum	235 °C ±5 °C, 2 ±0.5 second 245 °C ±5 °C, 2 ±0.5 second (lead free)
Temperature Rise	<75 °	100 % of its rated current, measure of surface temperature
Resistance to Dry Heat	±20 %	105 °C ±5 °C, 1000 hours
Resistance to Solvent	No evident damage on protective coating and marking	23 °C ±5 °C of isopropyl alcohol, 90 seconds
Residual Resistance	10k ohms or more	Measure DC resistance after fusing
Thermal Shock	ΔR < 10 %	-20 °C / +25 °C / +125 °C / +25 °C, 10 cycles

Environmental Characteristics

Operating Temperature	-20 °C to +105 °C
Storage Conditions	
Temperature	+5 °C to +35 °C
Humidity	40 % to 75 %
Shelf Life	2 years from manufacturing date
Moisture Sensitivity Level	1
ESD Classification (HBM)	Class 6

BOURNS®

Asia-Pacific:

Tel: +886-2 2562-4117
Email: asiacus@bourns.com

Europe:

Tel: +36 88 520 390
Email: eurocus@bourns.com

The Americas:

Tel: +1-951 781-5500
Email: americus@bourns.com

www.bourns.com

* RoHS Directive 2002/95/EC Jan 27 2003 including Annex.

** Bourns is using the definition that appears to be the prevalent definition used as the industry standard at this time. The Bourns definition of "halogen-free" is: Bromine (Br) content: ≤ 900 ppm; Chlorine (Cl) content: ≤ 900 ppm; Total Br + Cl content: ≤ 1500 ppm.

"SinglFuse" is a trademark of Bourns, Inc.

Specifications are subject to change without notice.

The device characteristics and parameters in this data sheet can and do vary in different applications and actual device performance may vary over time.

Users should verify actual device performance in their specific applications.

SingIFuse™ SF-1206F Series Applications

- Portable memory
- LCD monitors
- Disk drives
- PDAs
- Digital cameras
- DVDs
- Cell phones
- Rechargeable battery packs
- Battery chargers
- Set top boxes
- Industrial controllers

SF-1206F Series - Fast Acting Surface Mount Fuses **BOURNS®**

Typical Part Marking

Represents total content. Layout may vary.



RATING CURRENT (A)	
F = 0.50	T = 2.50
K = 0.80	3 = 3.00
L = 1.00	W = 4.00
M = 1.25	Y = 5.00
P = 1.50	Z = 7.00
S = 2.00	

How to Order

SF - 1206 F 050 - 2

SingIFuse™
Product Designator
SMD Footprint
3216 (1206) size
Fuse Blow Type
F = Fast acting
S = Slow blow
Rated Current
050-700 (500 mA - 7.00 A)
Packaging Type
- 2 = Tape & Reel (5,000 pcs./reel)

Construction & Material Content

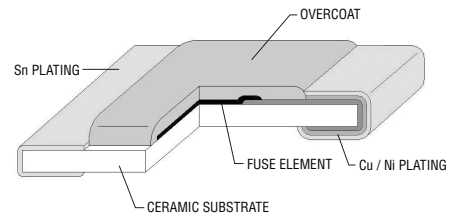

Product Dimensions

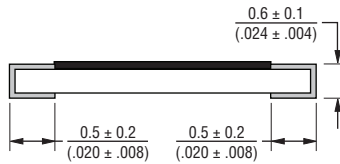
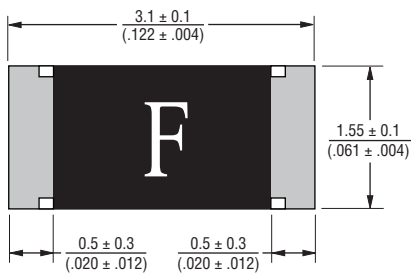

DIMENSIONS: $\frac{\text{MM}}{\text{(INCHES)}}$

PACKAGING: 5,000 pcs./reel

Recommended Pad Layout

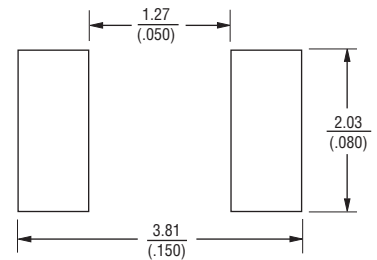

Thermal Derating Curve

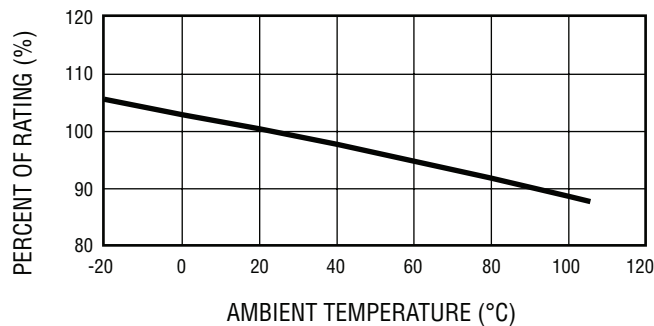

Specifications are subject to change without notice.
The device characteristics and parameters in this data sheet can and do vary in different applications and actual device performance may vary over time.
Users should verify actual device performance in their specific applications.

SF-1206F Series - Fast Acting Surface Mount Fuses



Average Time Current Curves

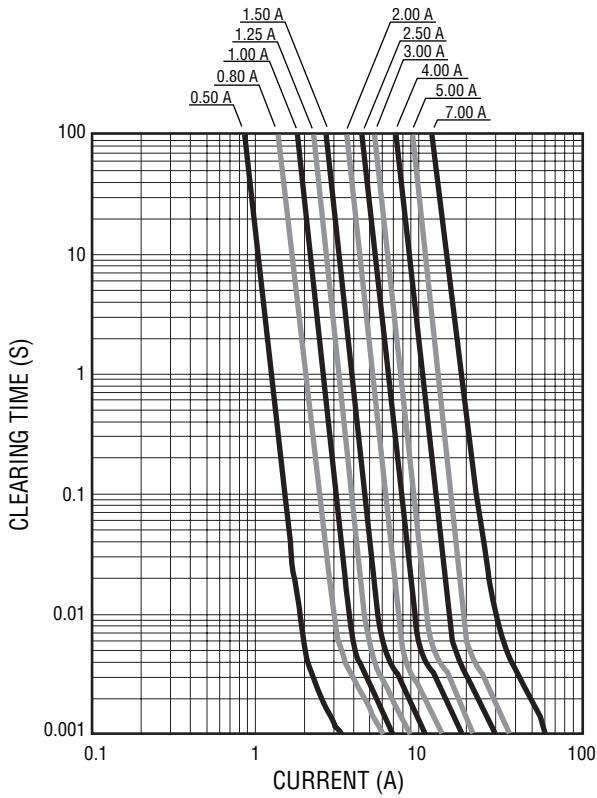

Minimum I²T V Clear Time Curves

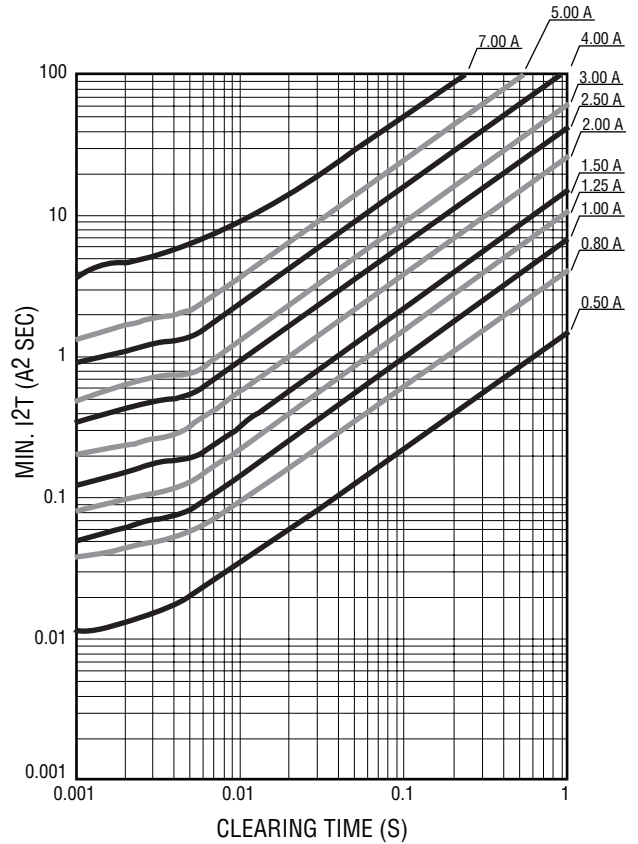

Solder Reflow Recommendations

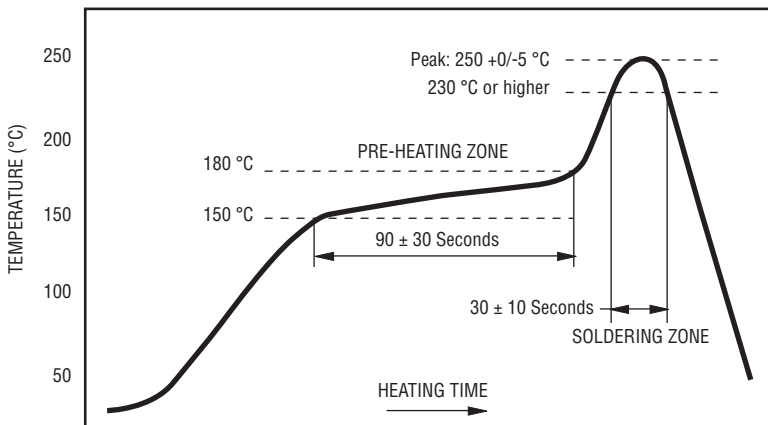

PEAK: 250 ± 5 °C, 5 seconds
 PRE-HEATING ZONE: 150 to 180 °C, 90 ± 30 seconds
 SOLDERING ZONE: 230 °C or higher, 30 ± 10 seconds

REV. E 07/17

Specifications are subject to change without notice.
 The device characteristics and parameters in this data sheet can and do vary in different applications and actual device performance may vary over time.
 Users should verify actual device performance in their specific applications.

SF-1206F Series Tape and Reel Specifications

BOURNS®

Tape Dimensions	SF-1206F Series per EIA 481-2
W	$\frac{8.0 \pm 0.2}{(.315 \pm .008)}$
P ₀	$\frac{4.0 \pm 0.1}{(.157 \pm .004)}$
P ₁	$\frac{4.0 \pm 0.1}{(.157 \pm .004)}$
P ₂	$\frac{2.0 \pm 0.05}{(.079 \pm .002)}$
A	$\frac{2.0 \pm 0.15}{(.079 \pm .006)}$
B	$\frac{3.6 \pm 0.2}{(.142 \pm .008)}$
F	$\frac{3.5 \pm 0.05}{(.138 \pm .002)}$
E	$\frac{1.75 \pm 0.1}{(.069 \pm .004)}$
D ₀	$\frac{1.5 + 0.1/-0}{(.059 + .004/-0)}$
T	$\frac{0.84 \pm 0.1}{(.033 \pm .004)}$
Reel Dimensions	
A	$\frac{180 +0/-3.0}{(7.087 +0/-118)}$
B Min.	$\frac{60.0}{(2.362)}$
C	$\frac{13.0 \pm 1.0}{(.512 \pm .039)}$
W	$\frac{9.0 \pm 1.0}{(.354 \pm .039)}$
T	$\frac{11.4 \pm 2.0}{(.449 \pm .079)}$

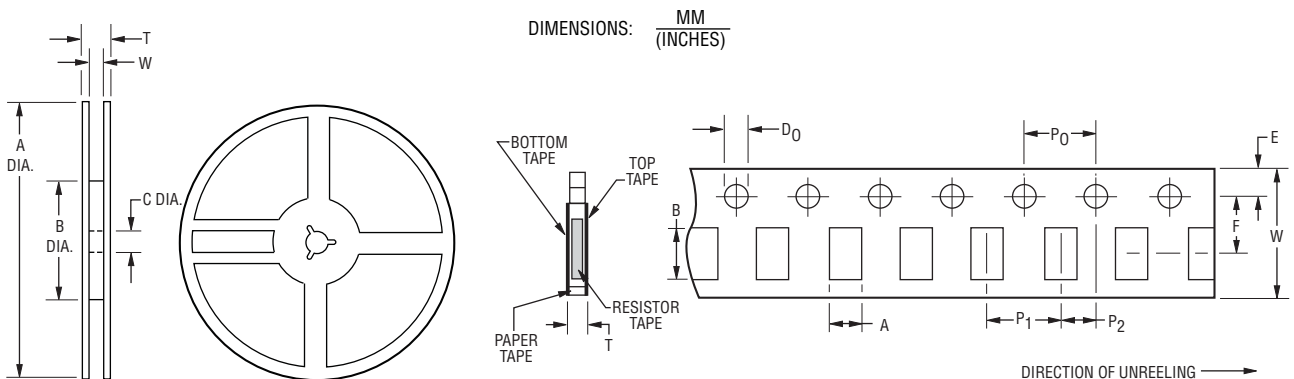

Specifications are subject to change without notice.
 The device characteristics and parameters in this data sheet can and do vary in different applications and actual device performance may vary over time.
 Users should verify actual device performance in their specific applications.