

阅读申明

- 1.本站收集的数据手册和产品资料都来自互联网，版权归原作者所有。如读者和版权方有任何异议请及时告之，我们将妥善解决。
- 2.本站提供的中文数据手册是英文数据手册的中文翻译，其目的是协助用户阅读，该译文无法自动跟随原稿更新，同时也可能存在翻译上的不当。建议读者以英文原稿为参考以便获得更精准的信息。
- 3.本站提供的产品资料，来自厂商的技术支持或者使用者的心得体会等，其内容可能存在描述上的差异，建议读者做出适当判断。
- 4.如需与我们联系，请发邮件到marketing@iczoom.com，主题请标有“数据手册”字样。

Read Statement

1. The datasheets and other product information on the site are all from network reference or other public materials, and the copyright belongs to the original author and original published source. If readers and copyright owners have any objections, please contact us and we will deal with it in a timely manner.
2. The Chinese datasheets provided on the website is a Chinese translation of the English datasheets. Its purpose is for reader's learning exchange only and do not involve commercial purposes. The translation cannot be automatically updated with the original manuscript, and there may also be improper translations. Readers are advised to use the English manuscript as a reference for more accurate information.
3. All product information provided on the website refer to solutions from manufacturers' technical support or users the contents may have differences in description, and readers are advised to take the original article as the standard.
4. If you have any questions, please contact us at marketing@iczoom.com and mark the subject with "Datasheets" .

MINI® Blade Fuses Rated 58V

MINI® style fuse for use in 42V Systems. Same Time-Current characteristic as the 32V MINI® fuse. Fits into standard MINI® fuse sockets. Has a rejection feature to prevent fuses with lower voltage rating from being wrongfully inserted into the circuit. Current rating 2A - 30A @58 VDC max.

Specifications

Interrupting Rating:	1000A @ 58 VDC
Voltage Rating:	58 VDC
*Component Level Temperature Range:	-40°C to +125°C
**System Level Temperature Range:	-40°C to +105°C
<i>105°C is a typical system level temperature requirement.</i>	
Terminals:	Ag plated zinc alloy
Housing Materials:	PA66
Complies with:	SAE J2077, SAE 2576 ISO 8820 UL 248 Special Purpose Fuses



MINI® Blade Fuses

Time-Current Characteristic Curves

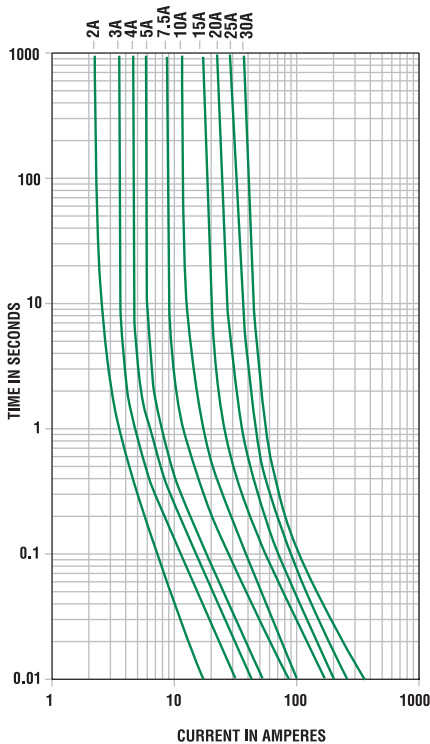

Component Level Temperature** = the maximum ambient temperature that a single fuse will survive. This does not factor-in the heat from a populated fuse box, but does include the heat from the current load with the proper rerating. *System Level Temperature** represents the ambient temperature of the fuse box at a location within the vehicle. The temperature within a populated fuse box (in a given location) will be higher. The limiting factor is the plating. Sn-plating's temperature limit is ~130°C, and Ag-plating allows up to 150°C at the terminal interface.

Ordering Information

Part Number	Package Size
0997xxx.WXN	3000

Time-Current Characteristics

% of Rating	Opening Time Min / Max (s)
110	360,000 s / -
135	0.75 s / 600 s
200	0.15 s / 5 s
350	0.080 s / 0.500 s
600	0.030 s / 0.100 s

Ratings

Part Number	Current Rating (A)	Housing Material Color	Typ. Voltage Drop (mV)	Cold Resistance (mΩ)	I ² t (A ² s)
0997002_	2	Grey	171	55.60	2.8
0997003_	3	Purple	153	33.75	9.4
0997004_	4	Pink	121	23.48	17
0997005_	5	Brown	129	17.75	25
099707.5_	7.5	Dark Brown	135	10.85	68
0997010_	10	Red	108	7.42	93
0997015_	15	Blue	98	4.58	270
0997020_	20	Yellow	96	3.21	380
0997025_	25	Light Orange	86	2.36	625
0997030_	30	Green	87	1.85	1130

Dimensions

Dimensions in mm

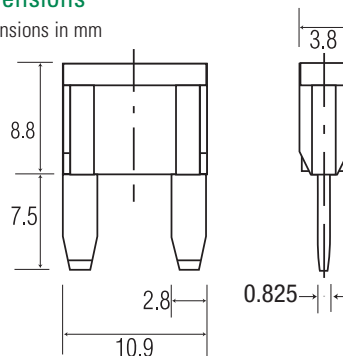

Temperature Rerating Curve

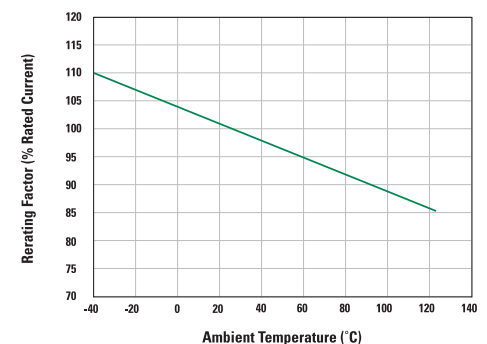

Littelfuse products are not designed for, and shall not be used for, any purpose (including, without limitation, automotive, military, aerospace, medical, life-saving, life-sustaining or nuclear facility applications, devices intended for surgical implant into the body, or any other application in which the failure or lack of desired operation of the product may result in personal injury, death, or property damage) other than those expressly set forth in applicable Littelfuse product documentation. Warranties granted by Littelfuse shall be deemed void for products used for any purpose not expressly set forth in applicable Littelfuse documentation. Littelfuse shall not be liable for any claims or damages arising out of products used in applications not expressly intended by Littelfuse as set forth in applicable Littelfuse documentation. The sale and use of Littelfuse products is subject to Littelfuse Terms and Conditions of Sale, unless otherwise agreed by Littelfuse.