

## 阅读申明

- 1.本站收集的数据手册和产品资料都来自互联网，版权归原作者所有。如读者和版权方有任何异议请及时告之，我们将妥善解决。
- 2.本站提供的中文数据手册是英文数据手册的中文翻译，其目的是协助用户阅读，该译文无法自动跟随原稿更新，同时也可能存在翻译上的不当。建议读者以英文原稿为参考以便获得更精准的信息。
- 3.本站提供的产品资料，来自厂商的技术支持或者使用者的心得体会等，其内容可能存在描述上的差异，建议读者做出适当判断。
- 4.如需与我们联系，请发邮件到marketing@iczoom.com，主题请标有“数据手册”字样。



## Read Statement

1. The datasheets and other product information on the site are all from network reference or other public materials, and the copyright belongs to the original author and original published source. If readers and copyright owners have any objections, please contact us and we will deal with it in a timely manner.
2. The Chinese datasheets provided on the website is a Chinese translation of the English datasheets. Its purpose is for reader's learning exchange only and do not involve commercial purposes. The translation cannot be automatically updated with the original manuscript, and there may also be improper translations. Readers are advised to use the English manuscript as a reference for more accurate information.
3. All product information provided on the website refer to solutions from manufacturers' technical support or users the contents may have differences in description, and readers are advised to take the original article as the standard.
4. If you have any questions, please contact us at marketing@iczoom.com and mark the subject with "Datasheets" .

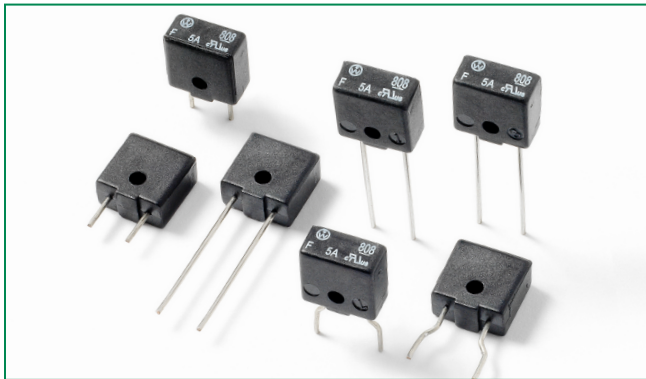
## 808 Series TE5® Fast-Acting 450V Fuse



### Agency Approvals

Agency	Agency File Number	Ampere Range
	NBK060111-JP1021A	2.00A - 5.00A
	E67006	2.00A - 5.00A

### Description

The 450V TE5® Fast-acting Fuse is designed to enable compliance with the RoHS Directive. This product is fully compatible with lead-free solder alloy. This device is UL Recognized for protecting components or internal circuits against overcurrent conditions at high DC voltages.

### Features

- Reduced PCB space requirements
- Direct solderable or plug-in versions
- Low internal resistance
- Halogen free, Lead-free, and RoHS compliant
- Shock safe casing
- Vibration resistant
- Antimony-free
- Ideal for high voltage DC applications
- Very high breaking capacity of 10kA at rated DC voltage

### Applications

- DC/DC Converter
- Transformer-less AC/DC Circuit
- Data Centers
- Telecom/Datacom Central Offices

### Additional Information



Datashheet



Resources



Samples

### Electrical Characteristics

% of Ampere Rating	Opening Time
100%	4 Hours, Minimum
200%	10 Seconds, Maximum

### Electrical Characteristics

Ampere Rating (A)	Amp Code	Max Voltage Rating (V)		Interrupting Rating <sup>1</sup>	Nominal Cold Resistance <sup>2</sup> (Ohms)	Nominal Melting I <sup>2</sup> t 10xI <sub>N</sub> (A <sup>2</sup> sec)	Max Voltage Drop 1.0xI <sub>N</sub> (mV)	Agency Approval 
		AC	DC					
2.00	1200	250	450	200A@250VAC 300A to 10kA@450VDC	0.069	0.0610	342	x
2.50	1250	250	450		0.054	0.0898	300	x
3.00	1300	250	350	200A@250VAC 300A to 10kA@350VDC	0.042	0.2007	276	x
3.15	1315	250	350		0.038	0.2191	270	x
4.00	1400	250	250	200A@250VAC 300A to 10kA@250VDC	0.027	0.5445	240	x
5.00	1500	250	250		0.022	1.1584	215	x

Notes:

1. This fuse is not recommended for use in DC circuits where the available prospective short-circuit current is less than 300A at rated voltage.
2. Cold resistance measured at less than 10% of rated current at 23°C.
3. An operating current of 80% or less of rated current is recommended, with further derating required at elevated ambient temperature.
4. Have special electrical characteristic needs? Contact Littelfuse to learn more about application specific options.

## Temperature Re-rating Curve

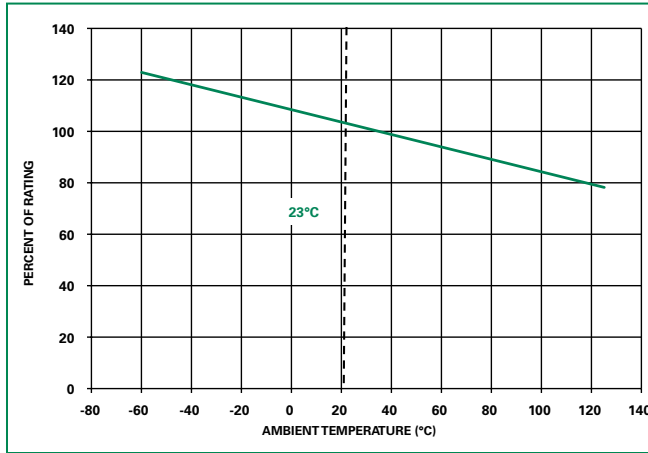

Note:

1. Rerating depicted in this curve is in addition to the standard derating of 20% for continuous operation.

## Average Time Current Curves

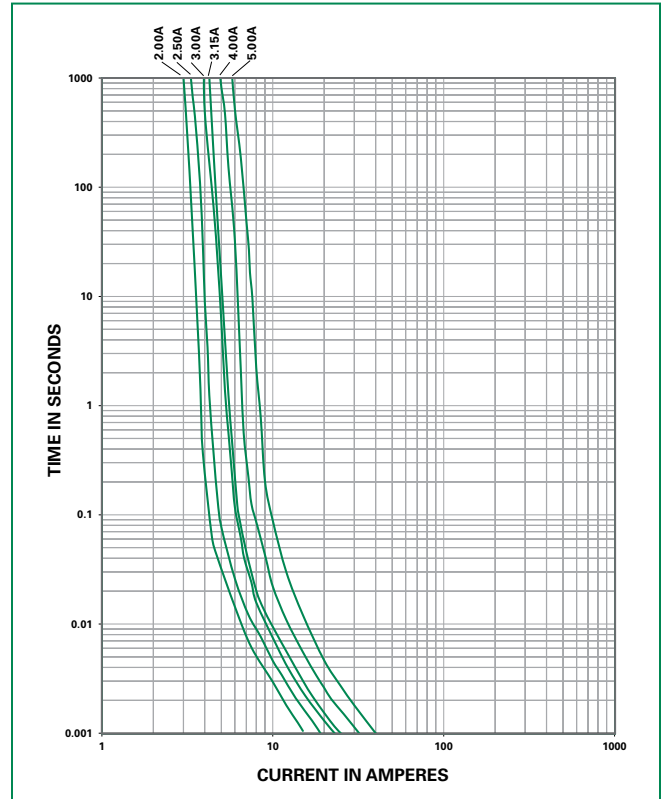

## Soldering Parameters - Wave Soldering

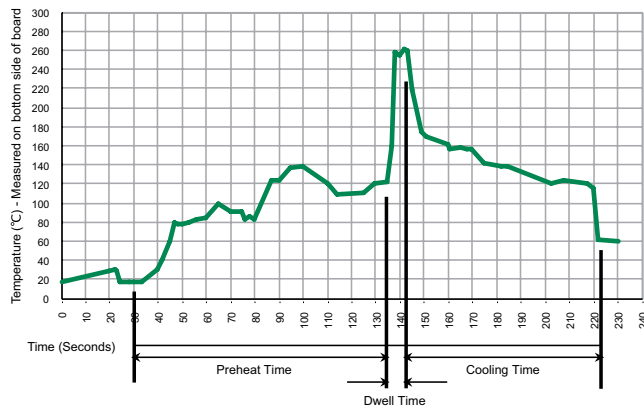

## Recommended Process Parameters:

Wave Parameter	Lead-Free Recommendation
<b>Preheat:</b> (Depends on Flux Activation Temperature)	(Typical Industry Recommendation)
Temperature Minimum:	100°C
Temperature Maximum:	150°C
Preheat Time:	60-180 seconds
<b>Solder Pot Temperature:</b>	260°C Maximum
<b>Solder Dwell Time:</b>	2-5 seconds

## Recommended Hand-Solder Parameters:

- Solder Iron Temperature: 350°C +/- 5°C
- Heating Time: 5 seconds max.

**Note: These devices are not recommended for IR or Convection Reflow process.**

### Product Characteristics

<b>Materials</b>	Base/Cap: Black Thermoplastic Polyphenylene Sulfide, UL 94 V-0 Round Pins: Copper, Sn-plated
<b>Product Marking</b>	Body: Brand Logo, Current Rating Rated Voltage, Characteristic "F"
<b>Solderability</b>	260°C, ≤ 3s. (Wave) 350°C, ≤ 1s. (Soldering Iron)
<b>Thermal Shock</b>	50 cycles, 15 minutes at -65°C/15 minutes at 125°C (MIL-STD-202, Method 107)

<b>Operating Temperature</b>	-65°C to +125°C (Consider re-rating)
<b>Moisture Resistance</b>	10 cycles, 65°C at 90-98% R.H. over 150 minutes, 180 minutes holding time, Reduce temperature to 23 – 35°C over 150 minutes, 8 hours holding time
<b>Vibration Resistance</b>	24 cycles at 5 min. each (IEC60068-2-6) 10-60Hz at 0.75mm amplitude 60-2000Hz at 10G's acceleration

### Dimensions

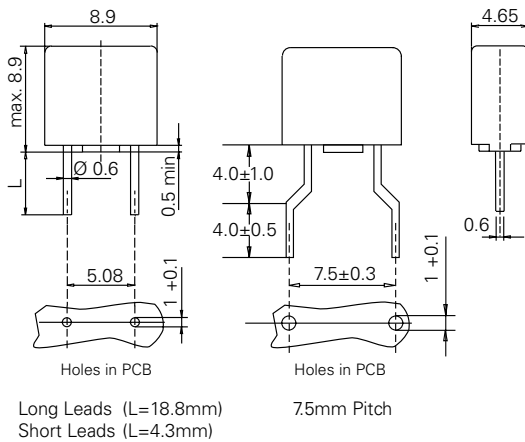

### Part Numbering System

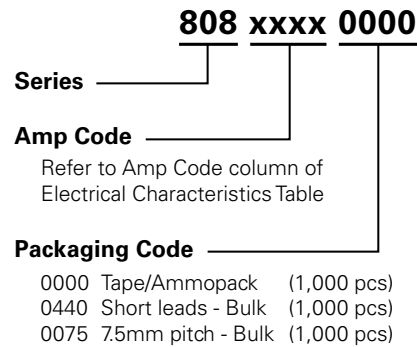

### Packaging

Packaging Option	Packaging Specification	Quantity	Quantity & Packaging Code	Taping Width
<b>808 Series</b>				
Tape & Ammopack	N/A	1,000	0000	N/A
Short Leads	N/A	1,000	0440	N/A
7.5 mm Pitch	N/A	1,000	0075	N/A

**Disclaimer Notice - Information furnished is believed to be accurate and reliable. However, users should independently evaluate the suitability of and test each product selected for their own applications. Littelfuse products are not designed for, and may not be used in, all applications. Read complete Disclaimer Notice at [www.littelfuse.com/disclaimer-electronics](http://www.littelfuse.com/disclaimer-electronics).**