

## 阅读申明

- 1.本站收集的数据手册和产品资料都来自互联网，版权归原作者所有。如读者和版权方有任何异议请及时告之，我们将妥善解决。
- 2.本站提供的中文数据手册是英文数据手册的中文翻译，其目的是协助用户阅读，该译文无法自动跟随原稿更新，同时也可能存在翻译上的不当。建议读者以英文原稿为参考以便获得更精准的信息。
- 3.本站提供的产品资料，来自厂商的技术支持或者使用者的心得体会等，其内容可能存在描述上的差异，建议读者做出适当判断。
- 4.如需与我们联系，请发邮件到marketing@iczoom.com，主题请标有“数据手册”字样。

## Read Statement

1. The datasheets and other product information on the site are all from network reference or other public materials, and the copyright belongs to the original author and original published source. If readers and copyright owners have any objections, please contact us and we will deal with it in a timely manner.
2. The Chinese datasheets provided on the website is a Chinese translation of the English datasheets. Its purpose is for reader's learning exchange only and do not involve commercial purposes. The translation cannot be automatically updated with the original manuscript, and there may also be improper translations. Readers are advised to use the English manuscript as a reference for more accurate information.
3. All product information provided on the website refer to solutions from manufacturers' technical support or users the contents may have differences in description, and readers are advised to take the original article as the standard.
4. If you have any questions, please contact us at marketing@iczoom.com and mark the subject with "Datasheets" .

SL1003A Series



**Description**

The SL1003A series has been especially developed for Broadband equipment. Special design features provide high levels of protection against fast rising transients in the 100V/μs to 1kV/μs range usually caused by lightning disturbances.

These devices have ultra low capacitance 1.5pF and present insignificant signal losses up to 1.5GHz. These devices are extremely robust and are able to divert a 5000A pulse without destruction. For AC Power Cross of long duration, over-current protection is recommended.

**Agency Approvals**

AGENCY	AGENCY FILE NUMBER
	E128662

**3 Electrode GDT Graphical Symbol**



**Features**

- RoHS compliant
- Low insertion loss
- Surface mountable
- 5kA surge capability tested with 8/20/μs pulse as defined by IEC 61000-4-5
- GHz working frequency
- Excellent response to fast rising transients
- Can be used to meet Telcordia GR1089 without series resistance
- 10/700 6kV capability, as per ITU-Tk.21, enhanced test level
- 2000 Amp 2/10μs surge rating

**Additional Information**



Datasheet



Resources



Samples

**Applications**

- Broadband equipment
- ADSL equipment
- XDSL equipment
- Satellite and CATV equipment
- General telecom equipment

### Electrical Characteristics

Part Number	Device Specifications (at 25°C)							Life Ratings												
	DC Breakdown in Volts <sup>1,2,3</sup> (@100V/s)			Impulse Breakdown in Volts <sup>2,3</sup> (@100V/μs)	Impulse Breakdown In Volts <sup>2,3</sup> (@1kV/μs)	Insulation Resistance	Capacitance (@1MHz 0V Bias)	Arc Voltage (on state Voltage) @1Amp Min	Surge Life (@200A 10/1000μs)	Nominal Impulse Discharge Current (@20μs)	Nominal AC Discharge Current (10x1s @50Hz)	AC Discharge Current (9 Cycles @ 50Hz)	DC Holdover Voltage <sup>4</sup>	Max Impulse Discharge Current (1 Application)						
	MIN	TYP	MAX	MAX		MIN	MAX	TYP					TYP	@ 10/350μs						
SL1003A090	72	90	108	600	700	10 <sup>9</sup> Ω (at 50V)	1.5 pF	~10 to 35 V	300 shots	10 shots (@10kA)	10 A	30 A	50 V	2 kA						
SL1003A230	184	230	276																	
SL1003A250	200	250	300																	
SL1003A260	210	260	310			750														
SL1003A300	240	300	360			850							10 <sup>9</sup> Ω (at 100V)							
SL1003A350	280	350	420			800														
SL1003A400	320	400	480			850														
SL1003A450	360	450	540			900														
SL1003A500	400	500	600		1100															

Notes:

- At delivery AQL 0.65 level II, DIN ISO 2859
- In ionized mode, tested according to ITU-T Rec. K.12
- Comparable to the silicon measurement Switching Voltage (Vs)
- Reference REA PE-80, 0.2A. Tested to ITU-T Rec. K.12 and REA PE-80 < 150 msec.

### Product Characteristics

<b>Materials</b>	<b>Leaded Device:</b> Tin-plated copper wire <b>Core and Surface Mount:</b> Dull Tin-plated
<b>Product Marking</b>	Littelfuse 'LF' Mark, voltage and date code

<b>Glow to Arc Transition Current</b>	~1 Amp
<b>Glow Voltage</b>	~60 to 200 Volts
<b>Storage and Operational Temperature</b>	-40 to +90°C

**Device Dimensions**

For SL1003A series:

Dimensions are in millimeters [and inches]

**'R' Type Radial Lead Devices (SL1003AxxxR-001)**

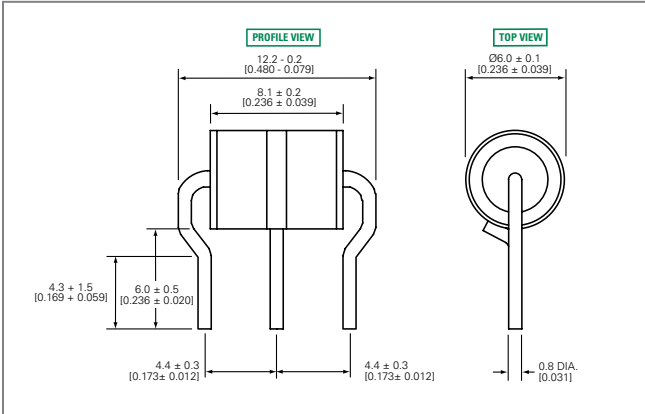

**'C' Type Core Devices**

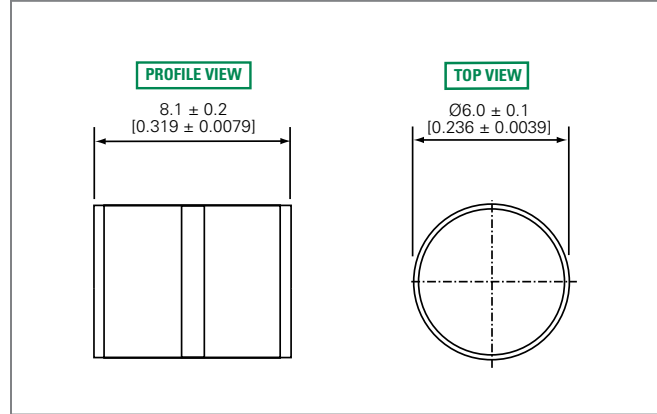

**'R' Type Radial Lead Devices (SL1003AxxxR and SL1003AxxxRF)**

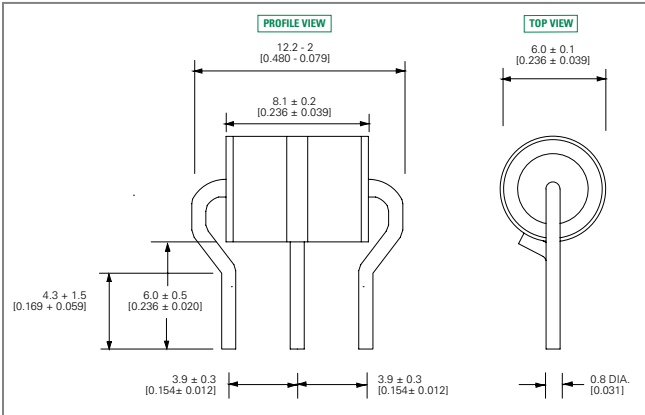

**'SM' Type Surface Mount Devices**

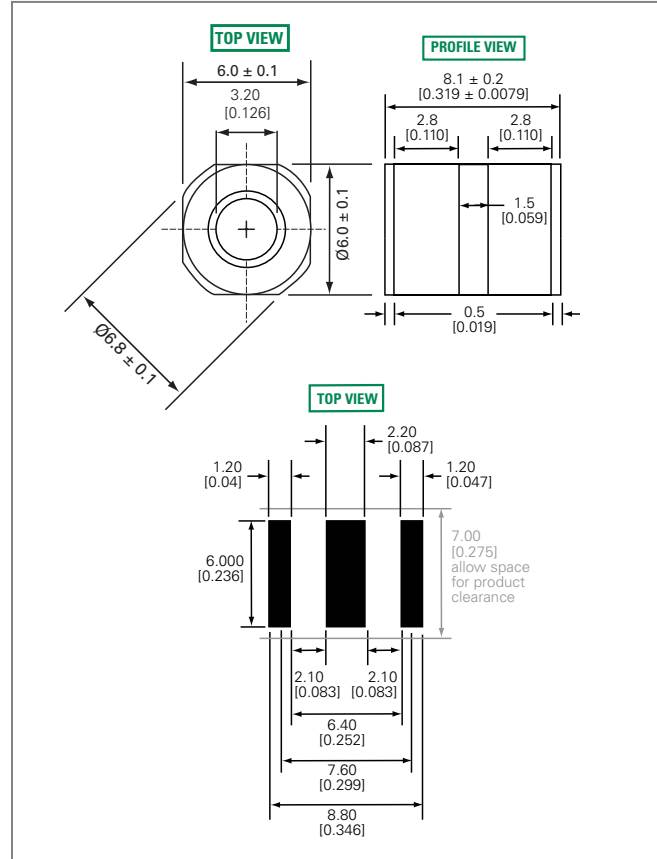

### Soldering Parameters - Reflow Soldering (Surface Mount Devices)

Reflow Condition		Pb-free assembly
Pre Heat	- Temperature Min ( $T_{s(min)}$ )	150°C
	- Temperature Max ( $T_{s(max)}$ )	200°C
	- Time (Min to Max) ( $t_s$ )	60 – 180 seconds
Average Ramp-up Rate (Liquidus Temp ( $T_L$ ) to peak)		3°C/second max.
$T_{s(max)}$ to $T_L$ - Ramp-up Rate		5°C/second max.
Reflow	- Temperature ( $T_L$ ) (Liquidus)	217°C
	- Temperature ( $t_L$ )	60 – 150 seconds
Peak Temperature ( $T_p$ )		260 <sup>+0/-5</sup> °C
Time within 5°C of Actual Peak Temperature ( $t_p$ )		10 – 30 seconds
Ramp-down Rate		6°C/second max.
Time 25°C to Peak Temperature ( $T_p$ )		8 minutes max.
Do not exceed		260°C

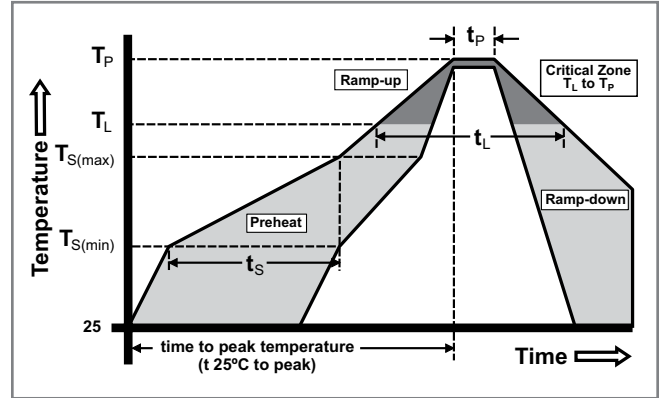

### Soldering Parameters - Wave Soldering (Thru-Hole Devices)

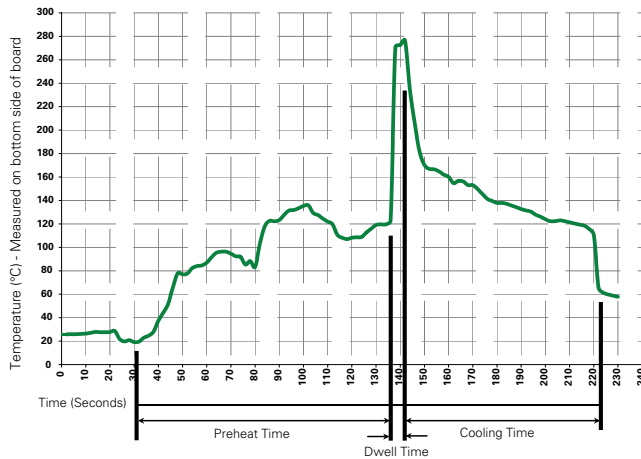

### Recommended Process Parameters:

Wave Parameter	Lead-Free Recommendation
<b>Preheat:</b>	
(Depends on Flux Activation Temperature)	(Typical Industry Recommendation)
Temperature Minimum:	100° C
Temperature Maximum:	150° C
Preheat Time:	60-180 seconds
<b>Solder Pot Temperature:</b>	280° C Maximum
<b>Solder Dwell Time:</b>	2-5 seconds

### Soldering Parameters - Hand Soldering

Solder Iron Temperature: 350° C +/- 5°C  
 Heating Time: 5 seconds max.

**Packaging**

**'C' Type Core Items:** Package bulk pack in polybag, 500 pcs/bag

**'R' and 'RF' Type Radial Lead Items:** Packed in tray, 100 pcs/tray

**'SM' Type Surface Mount Items:** Packaged tape and reel carrier, 700 pcs/reel (specifications below)

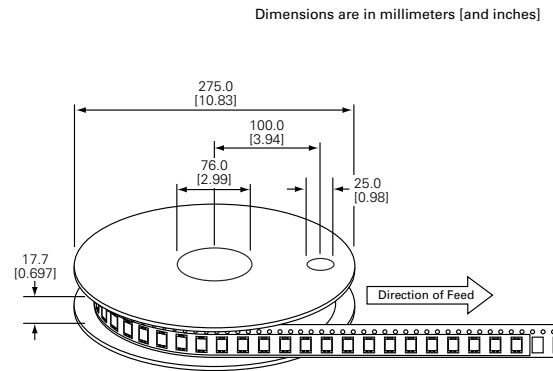
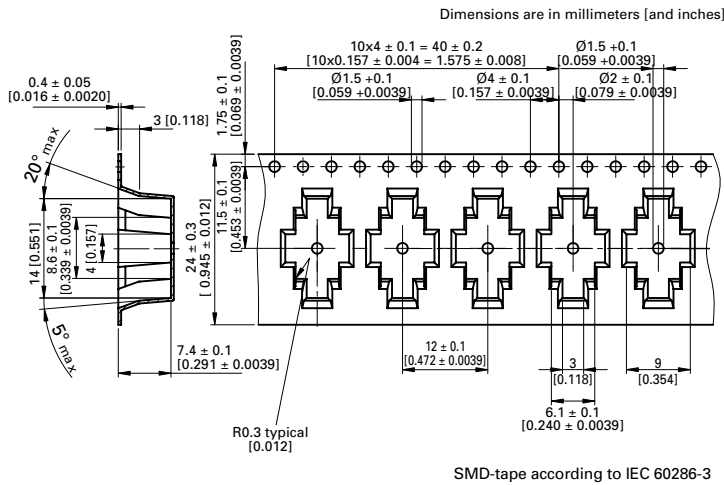

**Part Numbering System and Ordering Information**

**SL1003 A XXX XX**

**Type 3 Pole Arrestor**

**Voltage**

**Pin Configuration**

- C** = Core type (Packed in polybag, 500pcs/bag)
- R** = Radial Lead without Failsafe (Packed in tray, 100pcs/tray)
- RF** = Radial Lead with Failsafe (Packed in tray, 100pcs/tray)
- SM** = Surface Mount (Packed in carrier and tape, 700pcs/reel)