

## 阅读申明

- 1.本站收集的数据手册和产品资料都来自互联网，版权归原作者所有。如读者和版权方有任何异议请及时告之，我们将妥善解决。
- 2.本站提供的中文数据手册是英文数据手册的中文翻译，其目的是协助用户阅读，该译文无法自动跟随原稿更新，同时也可能存在翻译上的不当。建议读者以英文原稿为参考以便获得更精准的信息。
- 3.本站提供的产品资料，来自厂商的技术支持或者使用者的心得体会等，其内容可能存在描述上的差异，建议读者做出适当判断。
- 4.如需与我们联系，请发邮件到marketing@iczoom.com，主题请标有“数据手册”字样。

## Read Statement

1. The datasheets and other product information on the site are all from network reference or other public materials, and the copyright belongs to the original author and original published source. If readers and copyright owners have any objections, please contact us and we will deal with it in a timely manner.
2. The Chinese datasheets provided on the website is a Chinese translation of the English datasheets. Its purpose is for reader's learning exchange only and do not involve commercial purposes. The translation cannot be automatically updated with the original manuscript, and there may also be improper translations. Readers are advised to use the English manuscript as a reference for more accurate information.
3. All product information provided on the website refer to solutions from manufacturers' technical support or users the contents may have differences in description, and readers are advised to take the original article as the standard.
4. If you have any questions, please contact us at marketing@iczoom.com and mark the subject with "Datasheets" .

SL1021A/B Series



**Description**

GDT circuit protection devices dissipate electrical surge energy safely within a contained plasma gas. Commonly used to help protect sensitive telecom and networking equipment and lines, GDTs protect from damage that may result from lightning strikes and equipment switching operations.

The Littelfuse GDT series described in this document are available in a variety of leaded and surface mount forms and offered with and without optional fail-safe clip. Please refer to the electrical specifications, dimension and packaging options section of this document for additional information.

**SL1021A/B Series:**

SL1021A/B series GDTs are designed to offer high levels of performance on fast rising transients in the range of 100V/μS to 1KV/μS, which are those most likely created by induced lightning disturbances.

These devices feature ultra low capacitance (typically 1.5pF or less) and are extremely robust with SL1021A devices able to divert a 10,000 Amp pulse without destruction, and SL1021B suffix devices able to divert a 20,000 Amp pulse without destruction.

These series offer optimized internal geometry which provide low insertion loss at high frequencies, ideal for the protection of broadband and other high speed transmission equipment.

**Agency Approvals**

AGENCY	AGENCY FILE NUMBER
	E128662

**3 Electrode GDT Graphical Symbol**

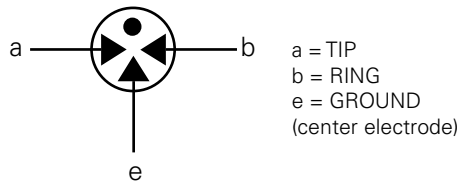

**Features**

- RoHS compliant
- Low insertion loss
- Excellent response to fast rising transients
- Ultra low capacitance
- 10KA (A suffix devices) / 20KA (B suffix devices) surge capability tested with 8/20μs pulse as defined by IEC 61000-4-5
- Available with thermal failsafe option (add 'F' suffix to part number)

**Applications**

- SL1021:**
- Broadband equipment
  - ADSL equipment
  - XDSL equipment
  - Satellite and CATV equipment
  - Splitters
  - General telecom equipment
  - Telecom network interfaces
  - Telephone line cards
  - Repeaters
  - Modems
  - Line test equipment

**Product Characteristics**

<b>Materials</b>	Dull Tin Plate 17.5 ± 12.5 Microns. with ceramic insulator
<b>Product Marking</b>	'LF' mark, voltage & date code: SL1021A - Red/White text SL1021B - Blue/White text
<b>Glow to arc transition current</b>	~ 1Amp
<b>Glow Voltage</b>	~60-200 Volts
<b>Storage and Operation Temperature</b>	-40 to +90°C
<b>Transverse Voltage (Delay Time)</b>	< 0.2μSec (Tested to ITU-T Rec. K.12)
<b>Arc Voltage</b>	~10 to 35 Volts
<b>Holdover Voltage</b>	<150mS (Tested to ITU-T Rec. K.12)

### Electrical Characteristics

Device Specifications (at 25°C)							Life Ratings					
Part Number	DC Voltage 100V/Sec.			DC Voltage 100 V/ $\mu$ Sec.	DC Voltage 1kV/ $\mu$ Sec.	Capacitance (@1Mhz)	Insulation Resistance	AC Current 50Hz 1Sec.x10 <sup>1</sup>	Surge Current 8/20 $\mu$ Sec x10 <sup>1</sup>	Max Single Surge 8/20 $\mu$ Sec <sup>1</sup>	Max Single Surge 10/350 $\mu$ Sec <sup>1</sup>	Surge Life 10/1000 $\mu$ Secx300 <sup>1</sup>
	MIN	TYP	MAX									
SL1021B075	60	75	90	500	650	<1.5pF	>10 <sup>10</sup> $\Omega$ (at 50V)	10Amps	10kA <sup>2</sup> 20kA <sup>3</sup>	15kA <sup>2</sup> 25kA <sup>3</sup>	4kA <sup>2</sup> 5kA <sup>3</sup>	200Amps
SL1021A090 SL1021B090	72	90	108									
SL1021A145 SL1021B145	116	145	174		600							
SL1021A150 SL1021B150	120	150	180									
SL1021A200	150	200	250									
SL1021A230 SL1021B230	184	230	276		450		650					
SL1021A250 SL1021B250	200	250	300		500							
SL1021A260 SL1021B260	210	260	310		550		700					
SL1021A300 SL1021B300	240	300	360		650		850					
SL1021A350 SL1021B350	280	350	420		700		900					
SL1021A400 SL1021B400	320	400	480		850		950					
SL1021A420 SL1021B420	345	420	500									
SL1021A450 SL1021B450	360	450	540		900		1000					
SL1021A500 SL1021B500	400	500	600		950		1100					
SL1021A600	480	600	720		1000		1200					

NOTES:

- Total current through centre electrode, tested in accordance with ITU-T Rec K.12
- SL1021A series
- SL1021B series

### Additional Information



**Datasheet  
SL1021A**



**Datasheet  
SL1021B**



**Resources  
SL1021A**



**Resources  
SL1021B**



**Samples  
SL1021A**



**Samples  
SL1021B**

**Time vs. Current for Failsafe**

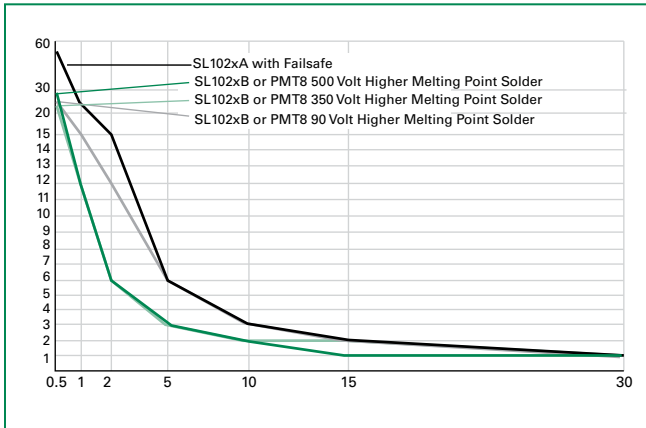

**Voltage vs. Time Characteristic**

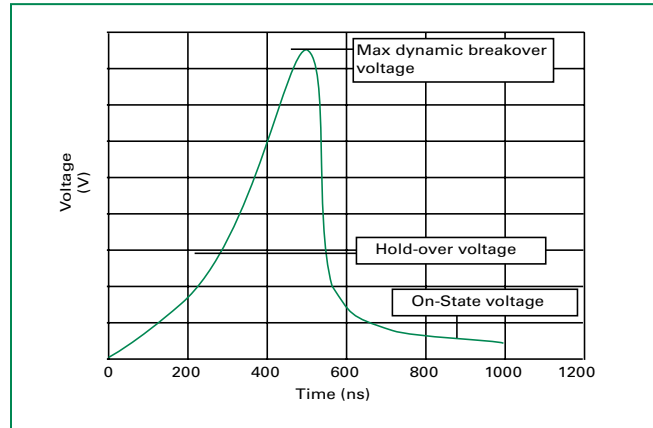

**Soldering Parameters - Reflow Soldering (Surface Mount Devices)**

Reflow Condition		Pb – Free assembly
Pre Heat	- Temperature Min ( $T_{s(min)}$ )	150°C
	- Temperature Max ( $T_{s(max)}$ )	200°C
	- Time (Min to Max) ( $t_s$ )	60 – 180 secs
Average ramp up rate (Liquidus Temp ( $T_L$ ) to peak)		3°C/second max
$T_{s(max)}$ to $T_L$ - Ramp-up Rate		5°C/second max
Reflow	- Temperature ( $T_L$ ) (Liquidus)	217°C
	- Temperature ( $t_l$ )	60 – 150 seconds
Peak Temperature ( $T_p$ )		260 <sup>+0/-5</sup> °C
Time within 5°C of actual peak Temperature ( $t_p$ )		10 – 30 seconds
Ramp-down Rate		6°C/second max
Time 25°C to peak Temperature ( $T_p$ )		8 minutes Max.
Do not exceed		260°C

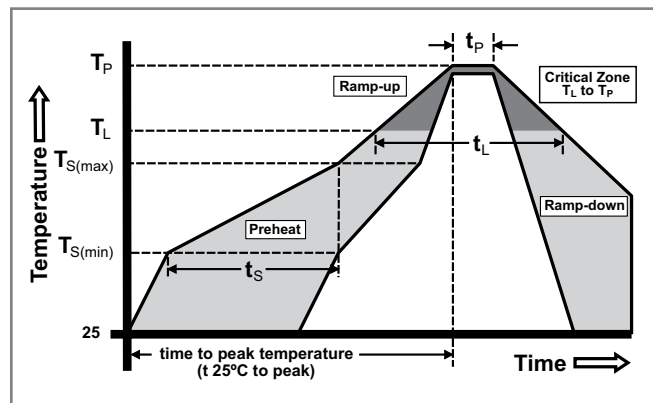

**Soldering Parameters - Hand Soldering**

Solder Iron Temperature: 350° C +/- 5°C  
Heating Time: 5 seconds max.

**Soldering Parameters - Wave Soldering (Thru-Hole Devices)**

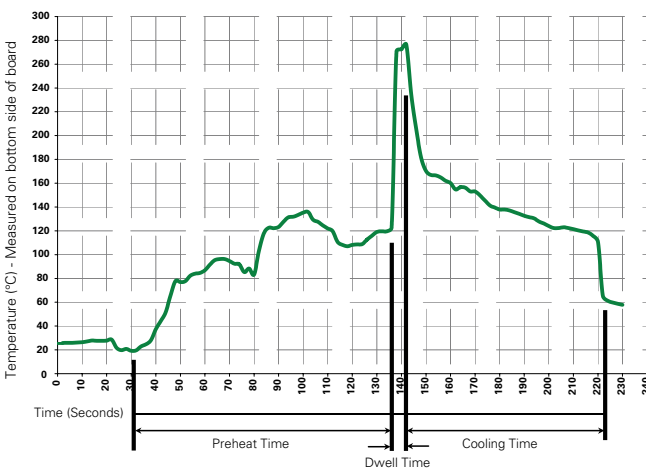

**Recommended Process Parameters:**

Wave Parameter	Lead-Free Recommendation
<b>Preheat:</b> (Depends on Flux Activation Temperature)	(Typical Industry Recommendation)
Temperature Minimum:	100° C
Temperature Maximum:	150° C
Preheat Time:	60-180 seconds
<b>Solder Pot Temperature:</b>	280° C Maximum
<b>Solder Dwell Time:</b>	2-5 seconds

Note: Surge Arrestors with a Failsafe mechanism should be individually examined after soldering

**Device Dimensions**

NOTE: Failsafe option dimensions shown in green.

**Shaped Radial Leaded Devices:**

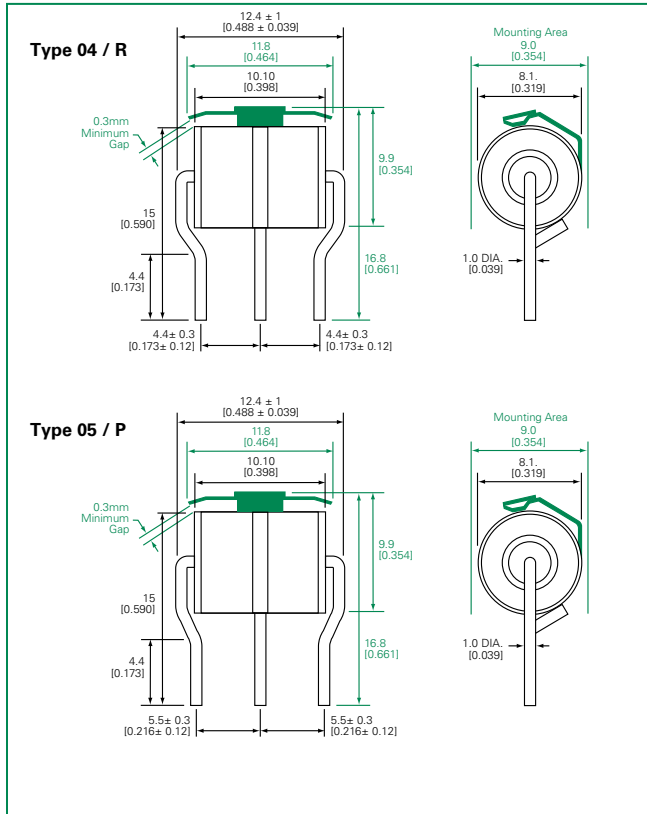

**Core Devices:**

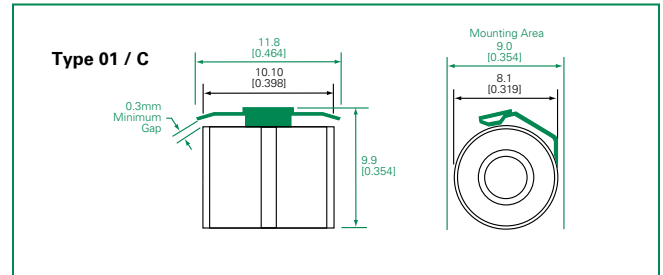

**Straight Radial Leaded Devices:**

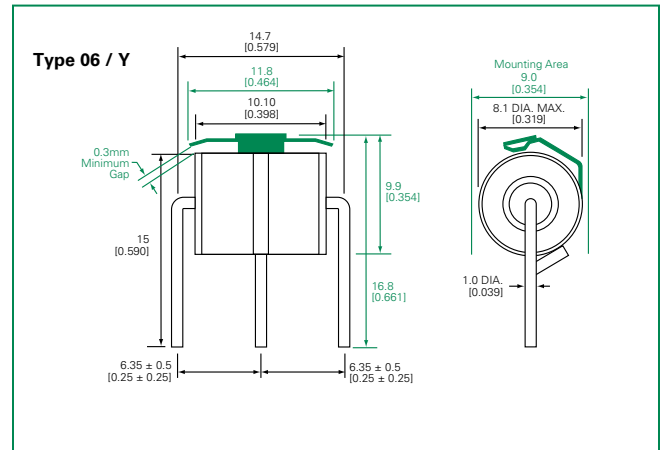

**Straight "T" Leaded Devices:**

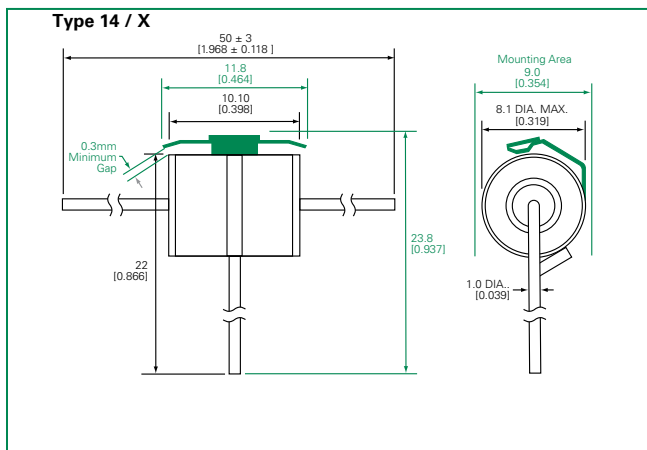

Type "R" is available for SL1021B075 device only.

**Part Numbering System and Ordering Information**

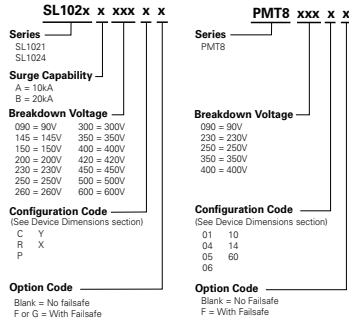

**Packaging**

**For 'SL1021A/B' device type C, R, P, Y packing**

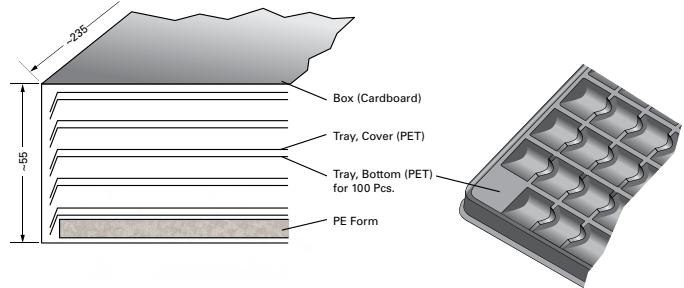

**For 'SL1021A/B' device type X packing**

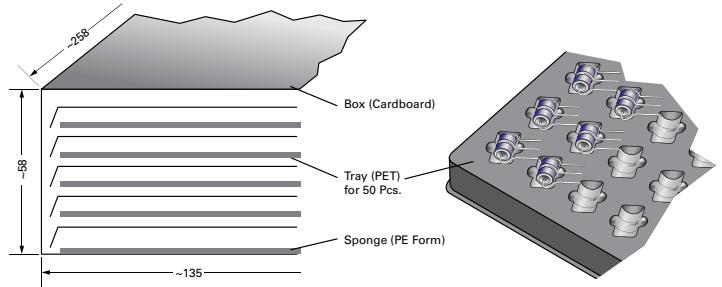

Device Type	Description	Quantity
Type C	100pcs/tray x 5 trays per carton	500
Type R	100pcs/tray x 5 trays per carton	500
Type P	100pcs/tray x 5 trays per carton	500
Type Y	100pcs/tray x 5 trays per carton	500
Type X	50pcs/tray x 5 trays per carton	250

\* Please contact the factory for further packaging information.