

## 阅读申明

- 1.本站收集的数据手册和产品资料都来自互联网，版权归原作者所有。如读者和版权方有任何异议请及时告之，我们将妥善解决。
- 2.本站提供的中文数据手册是英文数据手册的中文翻译，其目的是协助用户阅读，该译文无法自动跟随原稿更新，同时也可能存在翻译上的不当。建议读者以英文原稿为参考以便获得更精准的信息。
- 3.本站提供的产品资料，来自厂商的技术支持或者使用者的心得体会等，其内容可能存在描述上的差异，建议读者做出适当判断。
- 4.如需与我们联系，请发邮件到marketing@iczoom.com，主题请标有“数据手册”字样。

## Read Statement

1. The datasheets and other product information on the site are all from network reference or other public materials, and the copyright belongs to the original author and original published source. If readers and copyright owners have any objections, please contact us and we will deal with it in a timely manner.
2. The Chinese datasheets provided on the website is a Chinese translation of the English datasheets. Its purpose is for reader's learning exchange only and do not involve commercial purposes. The translation cannot be automatically updated with the original manuscript, and there may also be improper translations. Readers are advised to use the English manuscript as a reference for more accurate information.
3. All product information provided on the website refer to solutions from manufacturers' technical support or users the contents may have differences in description, and readers are advised to take the original article as the standard.
4. If you have any questions, please contact us at marketing@iczoom.com and mark the subject with "Datasheets" .

# TransFeed

## AVX Multilayer Ceramic Transient Voltage Suppressors TVS Protection and EMI Attenuation in a Single Chip



### GENERAL DESCRIPTION

AVX has combined the best electrical characteristics of its TransGuard® Transient Voltage Suppressors (TVS) and its Feedthru Capacitors into a single chip for state-of-the-art overvoltage circuit protection and EMI reduction over a broad range of frequencies. This unique combination of multilayer ceramic construction in a feedthru configuration gives the circuit designer a single 0805 chip that responds to transient events faster than any TVS device on the market today, and provides significant EMI attenuation when in the off-state.

The reduction in parallel inductance, typical of the feedthru chip construction when compared to the construction of standard TVS or ceramic capacitor chips, gives the TransFeed product two very important electrical advantages: (1) faster “turn-on” time. Calculated response times of <200 pSec are not unusual with this device, and measured response times range from 200 – 250 pSec. The TransFeed “turn-on” characteristic is less than half that of an equivalent TransGuard® part — and TransGuards® clamp transient voltages faster than any other bipolar TVS solution such as diodes; (2) the second electrical advantage of lower parallel inductance, coupled with optimal series inductance, is the enhanced attenuation characteristics of

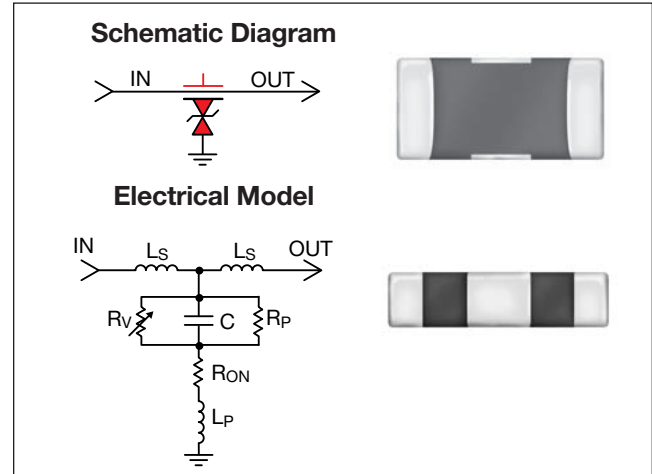

the TransFeed product. Not only is there significantly greater attenuation at a higher self-resonance frequency, but the roll-off characteristic becomes much flatter, resulting in EMI filtering over a much broader frequency spectrum. Typical applications include filtering/protection on Microcontroller I/O Lines, Interface I/O Lines, Power Line Conditioning and Power Regulation.

### GENERAL CHARACTERISTICS

- Operating Temperature: -55°C to +125°C
- Working Voltage: 5.6Vdc - 26 Vdc
- Case Size: 0805
- Energy Rating: 0.05 - 0.3J
- Current: 20 - 120A
- Max Feedthru Current: 0.5 - 1A

### TYPICAL APPLICATIONS

- Fingerprint ID Circuit
- Magnetic Field Circuit
- LCD Dashboard Driver

Where designers are concerned with both transient voltage protection and EMI attenuation, either due to the electrical performance of their circuits or due to required compliance to specific EMC regulations, the TransFeed product is an ideal choice.

### APPLICATIONS

- Bi-directional TVS
- Narrow band, high attenuation filter
- EMI Filtering over broader frequency range
- Fastest Response Time to ESD Strikes

# TransFeed

## AVX Multilayer Ceramic Transient Voltage Suppressors TVS Protection and EMI Attenuation in a Single Chip



### HOW TO ORDER

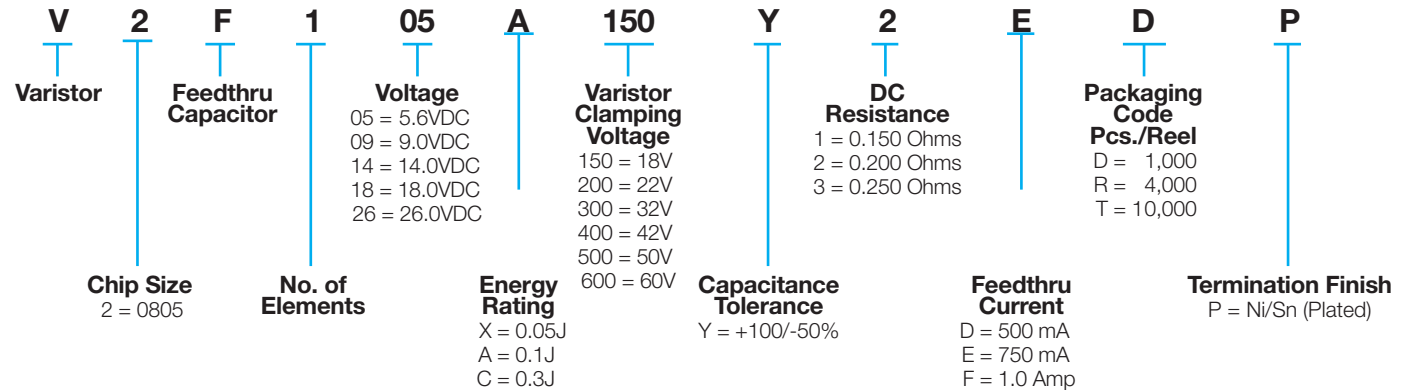

### TRANSFEED ELECTRICAL SPECIFICATIONS

AVX Part Number	Working Voltage (DC)	Working Voltage (AC)	Breakdown Voltage	Clamping Voltage	Maximum Leakage Current	Transient Energy Rating	Peak Current Rating	Typical Cap	DC Resistance	Maximum Feedthru Current
V2F105A150Y2E__	5.6	4.0	8.5±20%	18	35	0.10	30	800	0.200	0.75
V2F105C150Y1F__	5.6	4.0	8.5±20%	18	35	0.30	120	2500	0.150	1.00
V2F109A200Y2E__	9.0	6.4	12.7±15%	22	25	0.10	30	575	0.200	0.75
V2F109C200Y1F__	9.0	6.4	12.7±15%	22	25	0.30	120	1800	0.150	1.00
V2F114A300Y2E__	14.0	10.0	18.5±12%	32	15	0.10	30	300	0.200	0.75
V2F114C300Y1F__	14.0	10.0	18.5±12%	32	15	0.30	120	900	0.150	1.00
V2F118A400Y2E__	18.0	13.0	25.5±10%	42	10	0.10	30	200	0.200	0.75
V2F118C400Y1F__	18.0	13.0	25.5±10%	42	10	0.30	120	500	0.150	1.00
V2F118X500Y3D__	18.0	13.0	25.5±10%	50	10	0.05	20	75	0.250	0.50
V2F126C600Y2E__	26.0	18.0	34.5±10%	60	10	0.3	80	250	0.2	0.75

Termination Finish Code  
Packaging Code

$V_w$ (DC) DC Working Voltage (V)  
 $V_w$ (AC) AC Working Voltage (V)  
 $V_B$  Typical Breakdown Voltage (V @ 1mA<sub>DC</sub>)  
 $V_{B\text{Tol}}$   $V_B$  Tolerance is ± from Typical Value  
 $V_C$  Clamping Voltage (V @ 1A 8x20μS)  
 $I_L$  Maximum Leakage Current at the Working Voltage (μA)

$E_T$  Transient Energy Rating (J, 10x1000μS)  
 $I_p$  Peak Current Rating (A, 8x20μS)  
 Cap Typical Capacitance (pF) @ 1MHz and 0.5 V  
 DCR DC Resistance (Ohms)  
 $I_{FT}$  Maximum Feedthru Current (A)

# TransFeed

## AVX Multilayer Ceramic Transient Voltage Suppressors TVS Protection and EMI Attenuation in a Single Chip



dB Attenuation vs Frequency

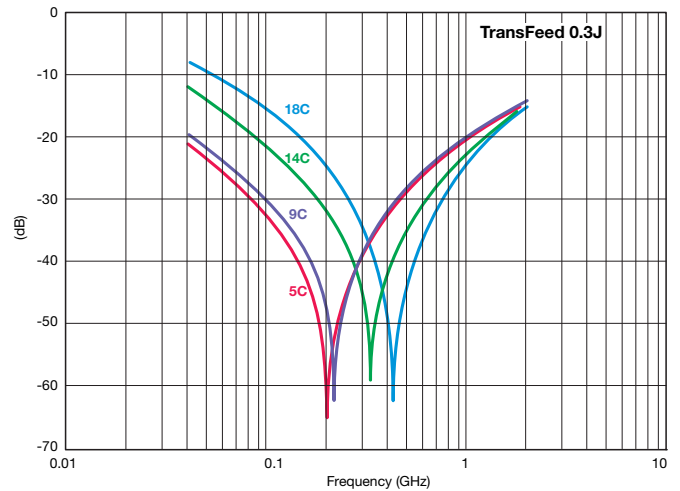
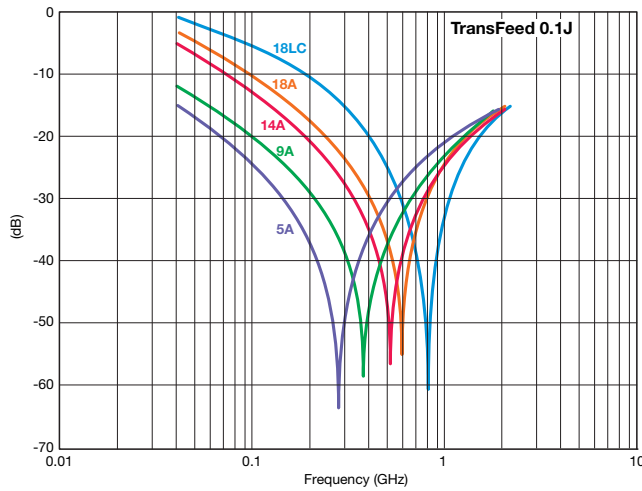

### DIMENSIONS

mm (inches)

	L	W	T	BW	BL	EW	X	S
0805	2.01 ± 0.20 (0.079 ± 0.008)	1.25 ± 0.20 (0.049 ± 0.008)	1.143 Max. (0.045 Max.)	0.46 ± 0.10 (0.018 ± 0.004)	0.18 + 0.25 - 0.08 (0.007 + 0.010 - 0.003)	0.25 ± 0.13 (0.010 ± 0.005)	1.02 ± 0.10 (0.040 ± 0.004)	0.23 ± 0.05 (0.009 ± 0.002)

### RECOMMENDED SOLDER PAD LAYOUT (Typical Dimensions)

mm (inches)

	T	P	S	W	L	C
0805	3.45 (0.136)	0.51 (0.020)	0.76 (0.030)	1.27 (0.050)	1.02 (0.040)	0.46 (0.018)

#### 4 Pad Layout

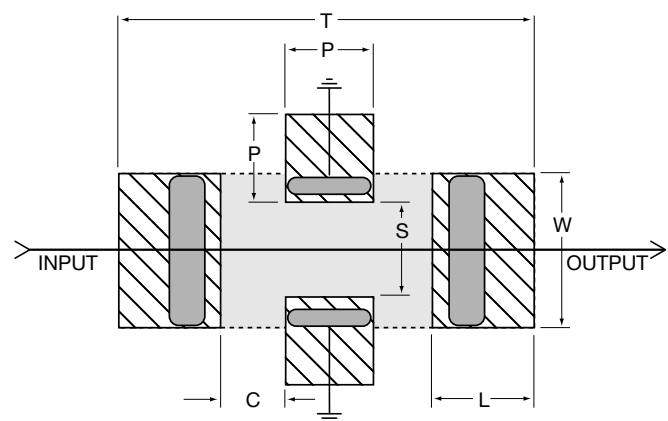
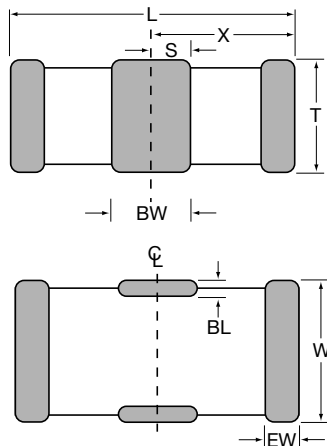

### PERFORMANCE CHARACTERISTICS

#### INSERTION LOSS COMPARISON (TransFeed vs TransGuard®)

##### 0805 – dB vs Frequency

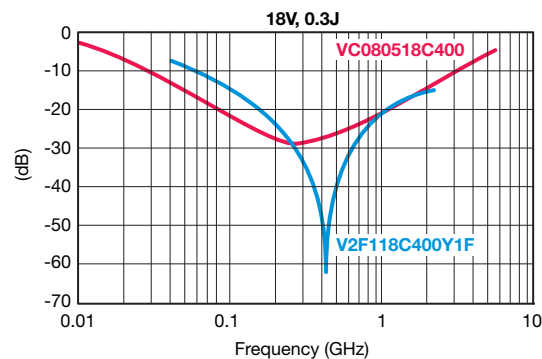
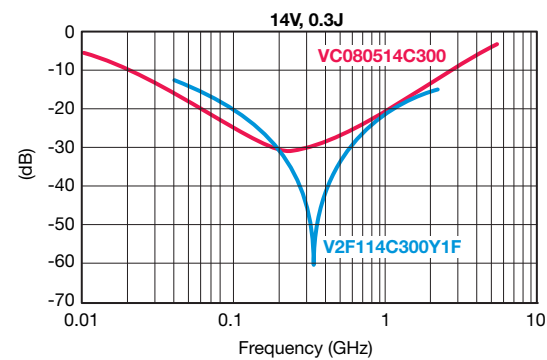
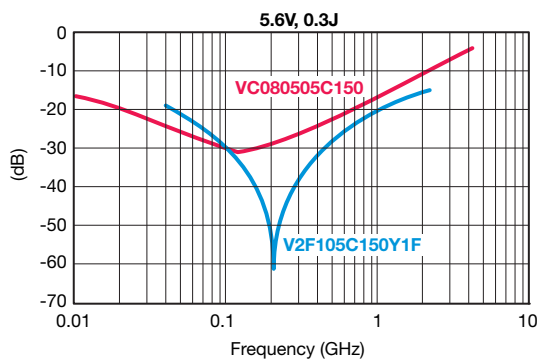
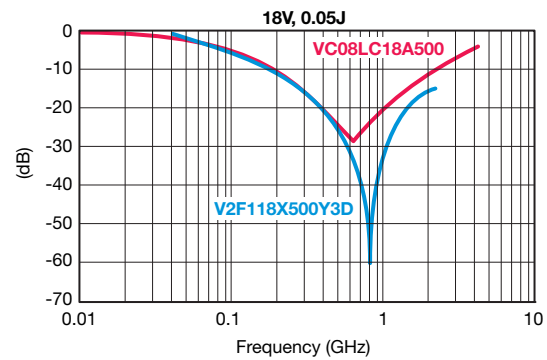
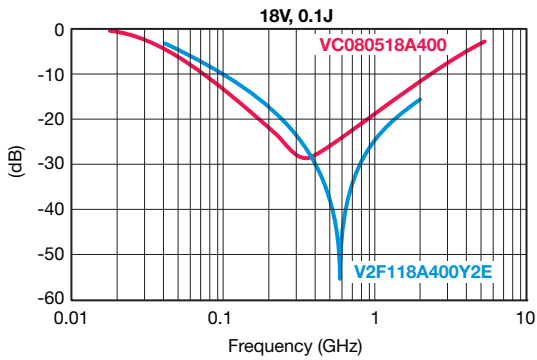
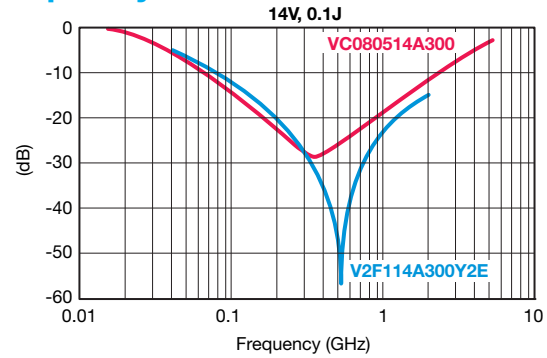
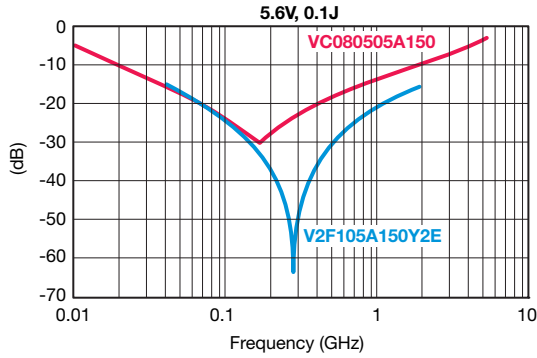

### PERFORMANCE CHARACTERISTICS

#### CURRENT vs TEMPERATURE

##### 0805 – 0.1 Joule

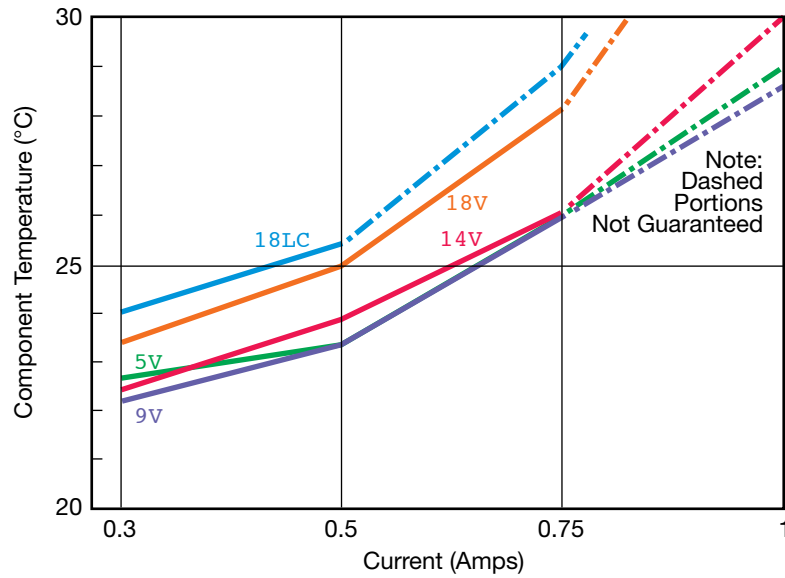

#### CURRENT vs TEMPERATURE

##### 0805 – 0.3 Joule

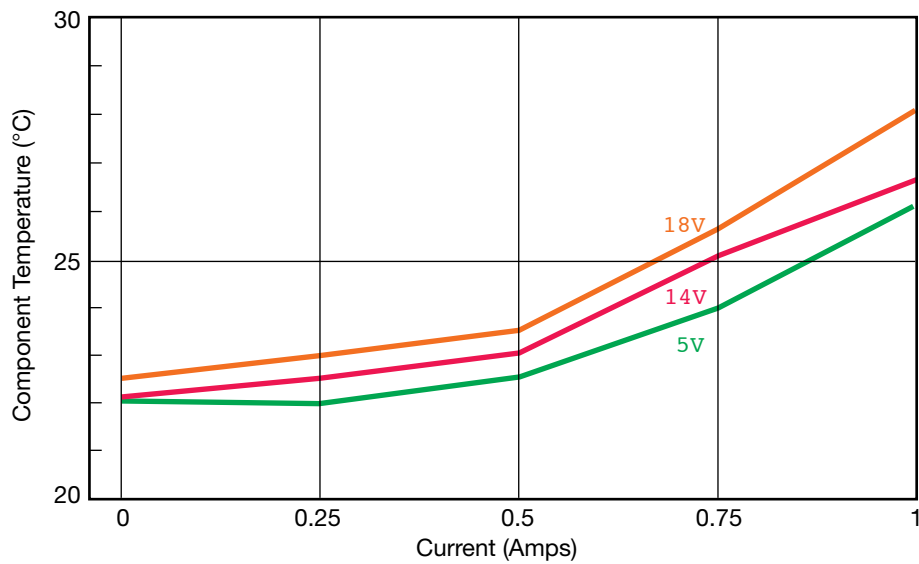

### PERFORMANCE CHARACTERISTICS

#### FEEDTHRU VARISTORS

AVX Multilayer Feedthru Varistors (MLVF) are an ideal choice for system designers with transient strike and broadband EMI/RFI concerns.

Feedthru Varistors utilize a ZnO varistor material and the electrode pattern of a feedthru capacitor. This combination allows the package advantage of the feedthru and material advantages of the ZnO dielectric to be optimized.

ZnO MLV Feedthrus exhibit electrical and physical advantages over standard ZnO MLVs. Among them are:

1. Faster Turn on Time
2. Broadband EMI attenuation
3. Small size (relative to discrete MLV and EMI filter schemes)

The electrical model for a ZnO MLV and a ZnO Feedthru MLV are shown below. The key difference in the model for the Feedthru is a transformation in parallel to series inductance. The added series inductance helps lower the injected transient peak current (by  $2\pi fL$ ) resulting in an additional benefit of a lower clamping voltage. The lowered parallel inductance decreases the turn on time for the varistor to <250ps.

**Discrete MLV Model**

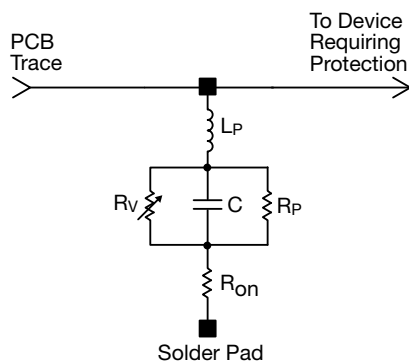

Where:  $R_v$  = Voltage Variable resistance (per VI curve)  
 $R_p \geq 10^{12} \Omega$   
 $C$  = defined by voltage rating and energy level  
 $R_{on}$  = turn on resistance  
 $L_p$  = parallel body inductance

**Discrete MLVF Model**

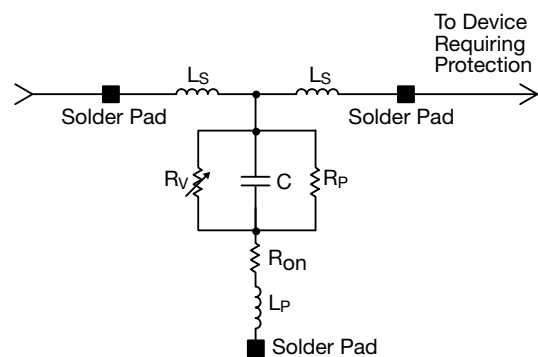

Where:  $R_v$  = Voltage Variable resistance (per VI curve)  
 $R_p$  = Body IR  
 $C$  = defined by voltage rating and energy level  
 $R_{on}$  = turn on resistance  
 $L_p$  = minimized parallel body inductance  
 $L_s$  = series body inductance

# TransFeed

## AVX Multilayer Ceramic Transient Voltage Suppressors TVS Protection and EMI Attenuation in a Single Chip



### PERFORMANCE CHARACTERISTICS

#### APPLICATIONS

- EMI Suppression
- Broadband I/O Filtering
- Vcc Line Conditioning

#### FEATURES

- Small Size
- Low ESR
- Ultra-fast Response Time
- Broad S21 Characteristics

#### MARKET SEGMENTS

- Computers
- Automotive
- Power Supplies
- Multimedia Add-On Cards
- Bar Code Scanners
- Remote Terminals
- Medical Instrumentation
- Test Equipment
- Transceivers
- Cellular Phones / Pagers

#### TYPICAL CIRCUITS REQUIRING TRANSIENT VOLTAGE PROTECTION AND EMI FILTERING

The following applications and schematic diagrams show where TransFeed TVS/ EMI filtering devices might be used:

- System Board Level Interfaces: (Fig. 1)  
Digital to RF  
Analog to Digital  
Digital to Analog
- Voltage Regulation (Fig. 2)
- Power Conversion Circuits (Fig. 3)
- GaAs FET Protection (Fig. 4)

Fig. 1 – System Interface

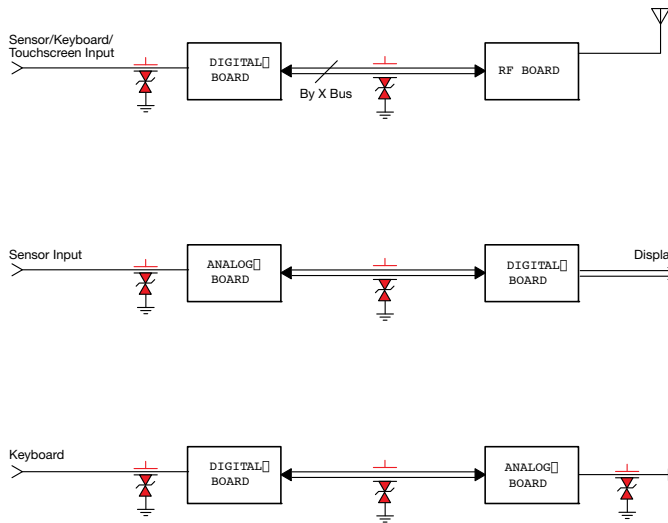

Fig. 2 – Voltage Regulators

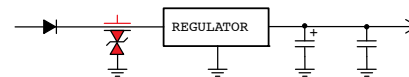

Fig. 3 – Power Conversion Circuits/Power Switching Circuits

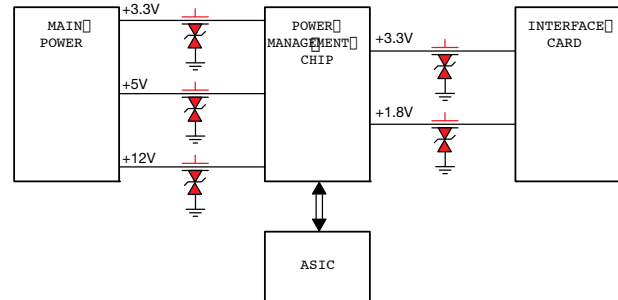
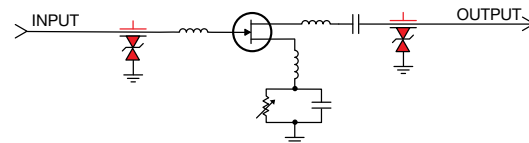

Fig. 4 – GaAs FET Protection



### SPECIFICATION COMPARISON

MLVF 0805	PARAMETER	MLV 0805
5ph	$L_s$ typical	N/A
<600nh	$L_p$ typical	<1.5nh
<0.025 $\Omega$	$R_{on}$ typical	<0.1 $\Omega$
100pf to 2.5nf	$C$ typical	100pf to 5.5nf
see VI curves	$R_v$ typical	see VI curves
>0.25 x 10 <sup>12</sup> $\Omega$	$R_p$ typical	>1 x 10 <sup>12</sup> $\Omega$
<250ps	Typical turn on time Typical frequency response	<500ps

A comparison table showing typical element parameters and resulting performance features for MLV and MLVF is shown above.