

阅读申明

- 1.本站收集的数据手册和产品资料都来自互联网，版权归原作者所有。如读者和版权方有任何异议请及时告之，我们将妥善解决。
- 2.本站提供的中文数据手册是英文数据手册的中文翻译，其目的是协助用户阅读，该译文无法自动跟随原稿更新，同时也可能存在翻译上的不当。建议读者以英文原稿为参考以便获得更精准的信息。
- 3.本站提供的产品资料，来自厂商的技术支持或者使用者的心得体会等，其内容可能存在描述上的差异，建议读者做出适当判断。
- 4.如需与我们联系，请发邮件到marketing@iczoom.com，主题请标有“数据手册”字样。

Read Statement

1. The datasheets and other product information on the site are all from network reference or other public materials, and the copyright belongs to the original author and original published source. If readers and copyright owners have any objections, please contact us and we will deal with it in a timely manner.
2. The Chinese datasheets provided on the website is a Chinese translation of the English datasheets. Its purpose is for reader's learning exchange only and do not involve commercial purposes. The translation cannot be automatically updated with the original manuscript, and there may also be improper translations. Readers are advised to use the English manuscript as a reference for more accurate information.
3. All product information provided on the website refer to solutions from manufacturers' technical support or users the contents may have differences in description, and readers are advised to take the original article as the standard.
4. If you have any questions, please contact us at marketing@iczoom.com and mark the subject with "Datasheets" .

MAX13325/MAX13326

Dual Automotive, Audio Line Drivers with I²C Control and Diagnostic

General Description

The MAX13325/MAX13326 dual audio line drivers provide a reliable differential interface between automotive audio components. The devices feature differential inputs and outputs, integrated output diagnostics, and are controlled using an I²C interface or operate in stand-alone mode. The outputs can deliver up to 4V_{RMS} into 100Ω loads.

The MAX13325 buffers analog audio signals for transmission over long cable distances with a fixed gain of 12dB, whereas the MAX13326 provides a 0dB fixed gain. The diagnostics on the outputs report conditions on a per channel basis, including short to GND, short to battery, overcurrent, overtemperature, and excessive offset. The output amplifiers can drive capacitive loads up to 4nF to ground and 3nF differentially.

The outputs are protected according to IEC 61000-4-2 ±8kV Contact Discharge, and ±15kV Air Gap. The MAX13325/MAX13326 are specified from -40°C to +105°C and are available in a 28-pin TSSOP package with an exposed pad.

Applications

Automotive Radio and Rear Seat Entertainment
Professional Remote Audio Amplifiers

Typical Operating Circuit

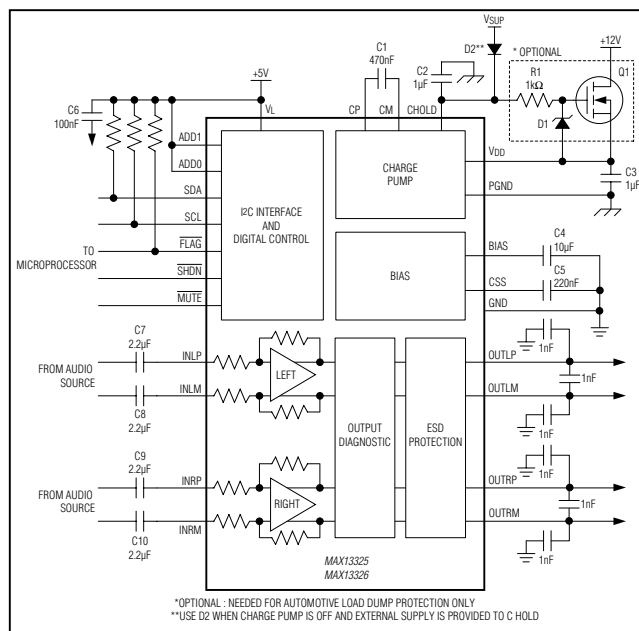

Features

- ◆ Comprehensive Programmability and Diagnostics Using I²C Interface
- ◆ Autoretry Function in Stand-Alone Mode
- ◆ Drive Capacitive Loads ≤ 3nF Differentially, ≤ 4nF to Ground
- ◆ 112dB Signal-to-Noise Ratio
- ◆ Low 0.002% THD at 4V_{RMS} into 2.7kΩ Loads
- ◆ High PSRR (70dB at 1kHz)
- ◆ High CMRR (80dB at 1kHz)
- ◆ Low Output Noise (3μV_{RMS}), MAX13326
- ◆ Excellent Channel-to-Channel Matching
- ◆ Load-Dump Transient Protection
- ◆ Protected Output Against Various Short-Circuit Conditions
- ◆ ESD Protection for ±8kV Contact Discharge, ±15kV Air Gap
- ◆ Long-Distance Drive Capability Typically Up to 15m or Greater
- ◆ Noise-Rejecting Differential Inputs and Outputs
- ◆ Low-Power Shutdown Mode < 10μA
- ◆ Hardware or Software MUTE Function
- ◆ 28-Pin TSSOP Package with Exposed Pad

Ordering Information

PART	PIN-PACKAGE	TEMP RANGE	GAIN (dB)
MAX13325GUI/V+	28 TSSOP-EP*	-40°C to +105°C	12
MAX13326GUI/V+	28 TSSOP-EP*	-40°C to +105°C	0

V denotes an automotive qualified part.

+Denotes a lead(Pb)-free/RoHS-compliant package.

*EP = Exposed pad.

For pricing, delivery, and ordering information, please contact Maxim Direct at 1-888-629-4642, or visit Maxim's website at www.maximintegrated.com.

MAX13325/MAX13326

Dual Automotive, Audio Line Drivers with I²C Control and Diagnostic

ABSOLUTE MAXIMUM RATINGS

VDD to PGND	-0.3V to +28V	Short Circuits Between Any OUT_	Continuous
CHOLD	-0.3V to +28V	Continuous Power Dissipation (TA = +70°C) (multilayer board)	
VL to GND	-0.3V to +6V	28-Pin TSSOP (derate 27mW/°C above +70°C).....	2162.2mW
GND, PGND	-0.3V to +0.3V	Operating Temperature Range.....	-40°C to +105°C
OUT_ to PGND.....	-0.3V to 28V	Storage Temperature Range.....	-65°C to +150°C
IN_, BIAS to AGND	-0.3V to (VDD + 0.3V)	Junction Temperature	+150°C
SCL, SDA, ADD0, ADD1, MUTE, SHDN,		Lead Temperature (soldering, 10s).....	+300°C
FLAG to GND	-0.3V to +6V	Soldering Temperature (reflow)	+260°C
OUT_ Short Circuit to PGND or VDD.....	Continuous		

Stresses beyond those listed under "Absolute Maximum Ratings" may cause permanent damage to the device. These are stress ratings only, and functional operation of the device at these or any other conditions beyond those indicated in the operational sections of the specifications is not implied. Exposure to absolute maximum rating conditions for extended periods may affect device reliability.

PACKAGE THERMAL CHARACTERISTICS (Note 1)

Junction-to-Ambient Thermal Resistance (θ_{JA})	37°C/W
Junction-to-Case Thermal Resistance (θ_{JC})	2°C/W

Note 1: Package thermal resistances were obtained using the method described in JEDEC specification JESD51-7, using a four-layer board. For detailed information on package thermal considerations, refer to www.maximintegrated.com/thermal-tutorial.

ELECTRICAL CHARACTERISTICS

(VDD = 14.4V, VL = 5V, RL = ∞, load impedance from OUT_+ to OUT_-, TA = TJ = -40°C to +105°C, typical values are TA = +25°C, unless otherwise noted.) (Note 2)

PARAMETER	SYMBOL	CONDITIONS	MIN	TYP	MAX	UNITS
AMPLIFIER DC CHARACTERISTICS						
Transient Supply Voltage (Load Dump)	VDDMAX	Using external nMOS-RTR020N05, 300ms duration			50	V
Operating Supply Voltage Range	VDD		4.5		18	V
	VL		2.7		5.5	
VDD OVLO Threshold	VDDOV	Rising edge	18.5	19.2		V
VDD UVLO Threshold	VDDUV	Falling edge	3.3	3.5		V
VL UVLO Threshold	VLUV	Falling edge	2.2	2.4		V
Supply Current	IDD	TA = +25°C, no load		39		mA
		TA = -40°C to +105°C, no load			50	mA
Logic Supply Current	IL	VL = 5V		1.7		mA
Shutdown Supply Current	ISHDN	IDD	TA = +25°C	0.5	10	μA
			TA = -40°C to +105°C	0.5		
		IL		< 0.1	2	μA
Turn-On Time (from Shutdown)		MUTE = VL		220		ms
Turn-On Time (from Mute)		SHDN = VL, CCSS = 220nF		6		ms
Differential Input Resistance	RINDIF	Measure across input	18	24	30	kΩ
Single-Ended Input Impedance	RIN	Each input to ground (MAX13325)	15	20	25	kΩ
		Each input to ground (MAX13326)	12	16	20	
Signal-Path Gain (Note 3)	Av	MAX13325	11.8	12	12.2	dB
		MAX13326	-0.2	0	+0.2	

MAX13325/MAX13326

Dual Automotive, Audio Line Drivers with I²C Control and Diagnostic

ELECTRICAL CHARACTERISTICS (continued)

(V_{DD} = 14.4V, V_L = 5V, R_L = ∞, load impedance from OUT₊ to OUT₋, T_A = T_J = -40°C to +105°C, typical values are T_A = +25°C, unless otherwise noted.) (Note 2)

PARAMETER	SYMBOL	CONDITIONS	MIN	TYP	MAX	UNITS
Channel-to-Channel Gain Tracking					±0.4	dB
Differential Mode Output Balance OUT ₊ to OUT ₋ (Note 4)				-40		dB
Output Offset Voltage (OUT ₊ to OUT ₋)	V _{OOS}	MUTE = GND, T _A = +25°C		±0.5	±10	mV
		MUTE = V _L , T _A = +25°C		±0.2	±3	
BIAS Voltage	V _{BIAS}	Relative to V _{DD}		50	52.5	%
BIAS Impedance	Z _{BIAS}	I _{BIAS} = ±10μA	69	92	115	kΩ
Output-Voltage Swing Differential		V _{DD} = 14.4V, V _{IN} = ±14.4V, R _L = 1kΩ	±12.5			V
		V _{DD} = 5.0V, V _{IN} = ±5V, R _L = 1kΩ	±4.2			
Power-Supply Rejection Ratio	PSRR	V _{DD} = 4.5V to 18V	-80	-96		dB
		V _{DD} = 14.5V, +500mVp-p ripple at 1kHz		-95		
		V _{DD} = 14.5V, +500mVp-p ripple at 10kHz		-80		
Common-Mode Rejection Ratio	CMRR	V _{IN} = 1V _{RMS} , 100Hz to 10kHz	-48	-80		dB
AMPLIFIER AC CHARACTERISTICS						
Total Harmonic Distortion Plus Noise (Note 5)	THD+N	V _{OUT} = 4V _{RMS} , R _L = 2.7kΩ	0.002			%
		V _{OUT} = 4V _{RMS} , R _L = 1kΩ	0.004			
		V _{OUT} = 4V _{RMS} , R _L = 100Ω, V _{DD} = 8V	0.03			
		V _{OUT} = 7V _{RMS} , R _L = 1kΩ	0.2			
Total Harmonic Distortion Plus Noise at V _{DD} = 5V (Note 5)	THD+N	V _{OUT} = 1V _{RMS} , R _L = 2.7kΩ	0.01			%
		V _{OUT} = 1V _{RMS} , R _L = 1kΩ	0.02			
		V _{OUT} = 2V _{RMS} , R _L = 1kΩ	0.8			
Capacitive-Load Stability					3	nF
Capacitive-Load Drive Capability		No sustained oscillation	C _{LOAD} to GND		4	nF
			C _{LOAD} differential		3	
Signal-to-Noise Ratio (Note 5)	SNR	MAX13325, gain = 12dB, V _{OUT} = 4V _{RMS} , A-weighted	112			dB
		MAX13326, gain = 0dB, V _{OUT} = 4V _{RMS} , A-weighted	122			
Unity-Gain Bandwidth				3		MHz
Output Slew Rate				2.5		V/μs
Output-Voltage Noise		A-weighted, MAX13325	10			μV
		A-weighted, MAX13326	3			
Crosstalk		V _{IN} = 1V _{RMS} , 1kHz	-110			dB
Mute Time		To achieve soft mute, C _{CSS} = 220nF	4			ms
Mute Attenuation		V _{IN} = 1V _{RMS} , 1kHz	-75			dB
Click-and-Pop Level (Note 6)	K _{CP}	Into and out of mute	-70			dBV
Click-and-Pop Level (Note 6)	K _{CP}	Into and out of shutdown, 1kΩ	-45			dBV

MAX13325/MAX13326

Dual Automotive, Audio Line Drivers with I²C Control and Diagnostic

ELECTRICAL CHARACTERISTICS (continued)

(V_{DD} = 14.4V, V_L = 5V, R_L = ∞, load impedance from OUT₊ to OUT₋, T_A = T_J = -40°C to +105°C, typical values are T_A = +25°C, unless otherwise noted.) (Note 2)

PARAMETER	SYMBOL	CONDITIONS	MIN	TYP	MAX	UNITS
CHARGE PUMP						
Charge-Pump Overdrive Voltage, V _{CHOLD} - V _{DD} (Hard Mode)	V _{CPH}	V _{DD} = 4.5V, I _{SOURCE} = 6.6mA	3.2	4.0		V
		V _{DD} = 18V, I _{SOURCE} = 6.6mA	4.5		5.5	
V _{CHOLD} - V _{DD} (Soft Mode)	V _{CPS}	V _{DD} unconnected, I _{SOURCE} = 40μA, V _L = 3.3V		2.1		V
		V _L = 5V		3.9		
Charge-Pump Frequency	f _{CP}	CPOFF = 0	CPF[1:0] = 00	333		kHz
			CPF[1:0] = 01	190		
			CPF[1:0] = 10	426		
			CPF[1:0] = 11	260		
DIAGNOSTICS						
Output Current Limit		Short to GND or battery		580		mA
Current-Limit Warning Threshold				230		mA
Open-Load Detection			10			kΩ
Output Offset Detection		Valid when muted		±250		mV
Thermal Warning Threshold				135		°C
Thermal Shutdown Threshold				165		°C
Thermal Shutdown Hysteresis				15		°C
ESD PROTECTION						
Air Gap IEC 61000-4-2		OUT ₋ pins		±15		kV
Contact Discharge IEC 61000-4-2		OUT ₋ pins		±8		kV
HBM		All pins		±2		kV

MAX13325/MAX13326

Dual Automotive, Audio Line Drivers with I²C Control and Diagnostic

DIGITAL CHARACTERISTICS

(V_{DD} = 14.4V, V_L = 3.3V, T_A = T_J = -40°C to +105°C, typical values are T_A = +25°C, unless otherwise noted.) (Note 2)

PARAMETER	SYMBOL	CONDITIONS	MIN	TYP	MAX	UNITS
DIGITAL INTERFACE						
Input-Voltage High	V _{INH}	V _L = 2.7V to 5.5V	0.75 x V _L			V
Input-Voltage Low	V _{INL}	V _L = 2.7V to 5.5V			0.25 x V _L	V
Input-Voltage Hysteresis				50		mV
Input Leakage Current					±100	μA
Output Low Voltage		FLAG, SDA, I _{SINK} = 3mA			0.4	V
Output Leakage Current		FLAG, SDA = 5.5V			2	μA
Stand-Alone FLAG Pulse Width		ADD0, ADD1 = GND		100		ms
Stand-Alone Fault Retry Time		ADD0, ADD1 = GND		500		ms
I²C TIMING						
Serial-Clock Frequency	f _{SCL}		0		400	kHz
Bus Free Time	t _{BUF}	Between START and STOP conditions	1.3			μs
Hold Time	t _{HD:STA}	Repeated START condition	0.6			μs
SCL Low Time	t _{LOW}		1.3			μs
SCL High Time	t _{HIGH}		0.6			μs
Data Hold Time	t _{HD:DAT}		0		900	ns
Data Setup Time	t _{SU:DAT}		100			ns
Bus Capacitance	C _B	Per bus line			400	pF
Receiving Rise Time	t _R	SCL, SDA	20 + 0.1C _B		300	ns
Receiving Fall Time	t _F	SCL, SDA	20 + 0.1C _B		300	ns
Transmitting Fall Time	t _F	SDA, V _L = 3.6V	20 + 0.05C _B		250	ns
STOP Condition Setup Time	t _{SU:STO}		0.6			μs
Pulse Width of Suppressed Spike	t _{SP}		0		50	ns

Note 2: All devices are 100% tested at T_A = +25°C. Limits over temperature are guaranteed by design.

Note 3: Signal path gain is defined as: $20 \times \log \left(\frac{|V_{OUT+}| - |V_{OUT-}|}{|V_{IN+}| - |V_{IN-}|} \right)$.

Note 4: Measured in differential output mode, differential input voltage 4V_{P-P} (for 0dB gain), 1V_{P-P} (for 12dB gain) 1kHz.

Common-mode output balance is defined as: $20 \times \log \left(\frac{||V_{OUT+}| - |V_{OUT-}||}{(|V_{OUT+}|) + (|V_{OUT-}|) \times 2} \right)$.

Note 5: 22Hz to 22kHz measurement bandwidth.

Note 6: KCP level is calculated as 20log[(peak voltage during mode transition, no input signal)/1V_{RMS}]. Units are expressed in dBV.

MAX13325/MAX13326

Dual Automotive, Audio Line Drivers with I²C Control and Diagnostic

Typical Operating Characteristics

(V_{DD} = 14.4V, V_L = 5V, R_L = 1kΩ, gain = 12dB, T_A = +25°C, unless otherwise noted.)

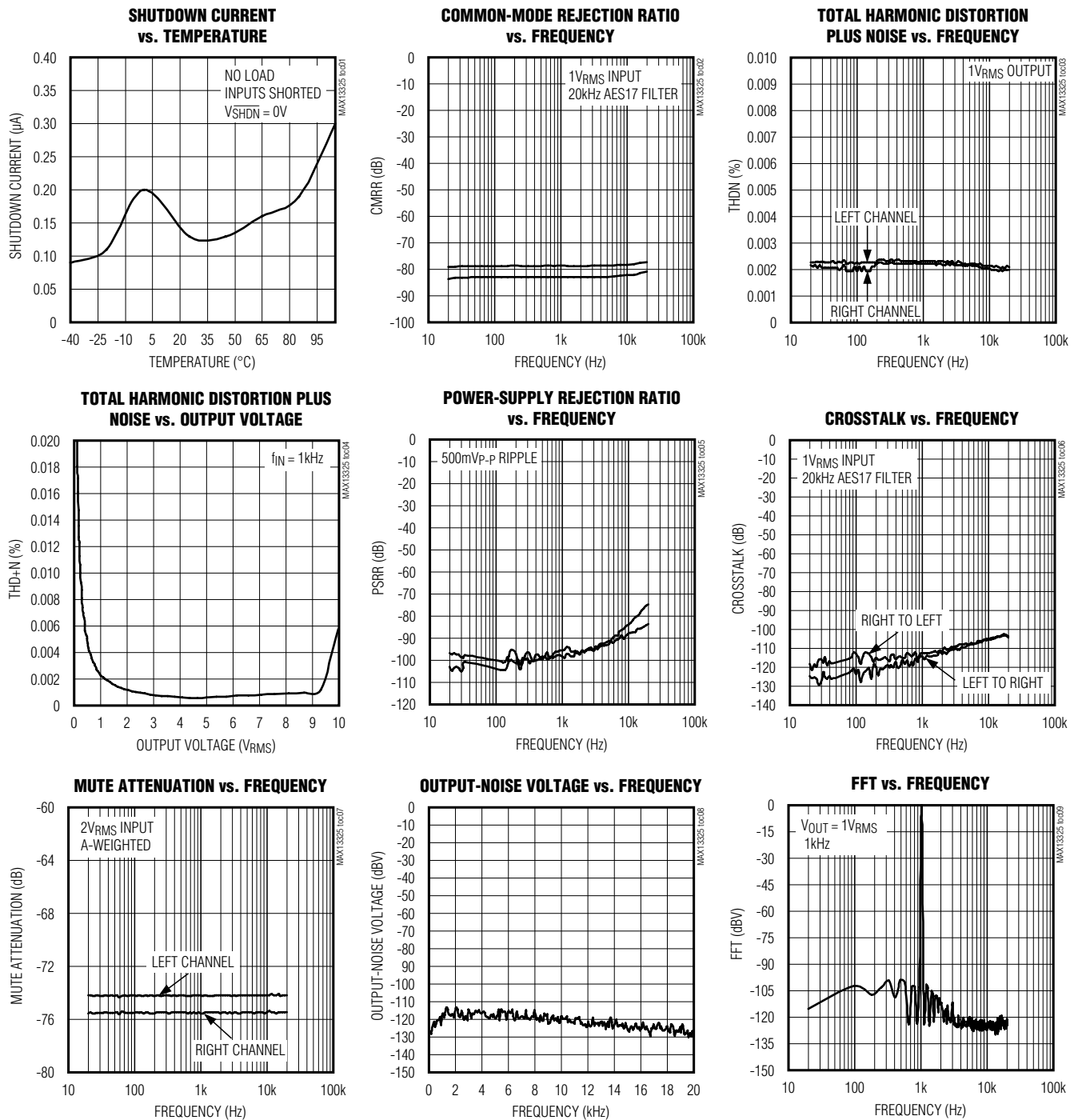

MAX13325/MAX13326

Dual Automotive, Audio Line Drivers with I²C Control and Diagnostic

Typical Operating Characteristics (continued)

(V_{DD} = 14.4V, V_L = 5V, R_L = 1k Ω , gain = 12dB, T_A = +25°C, unless otherwise noted.)

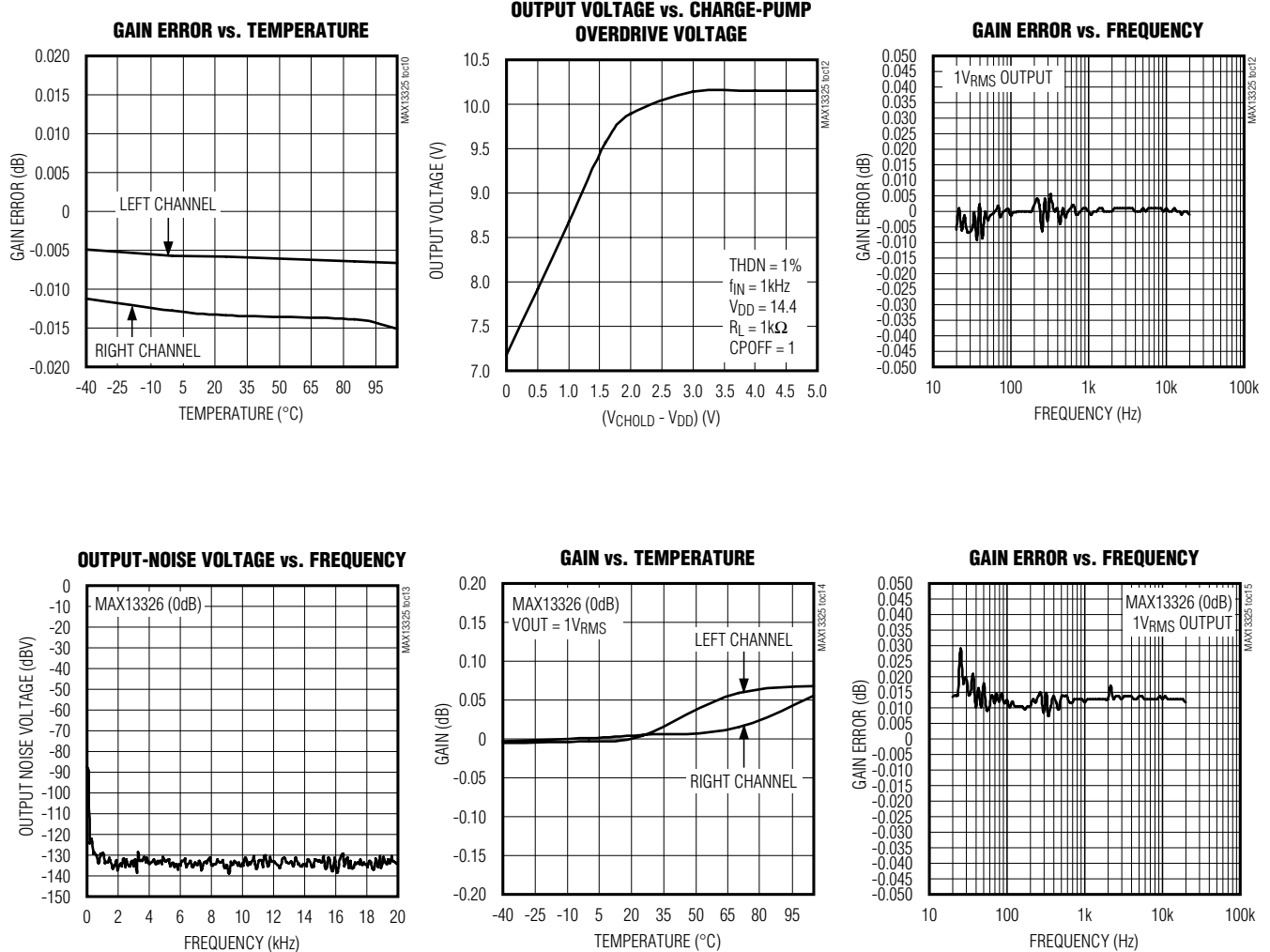

MAX13325/MAX13326

Dual Automotive, Audio Line Drivers with I²C Control and Diagnostic

Pin Configuration

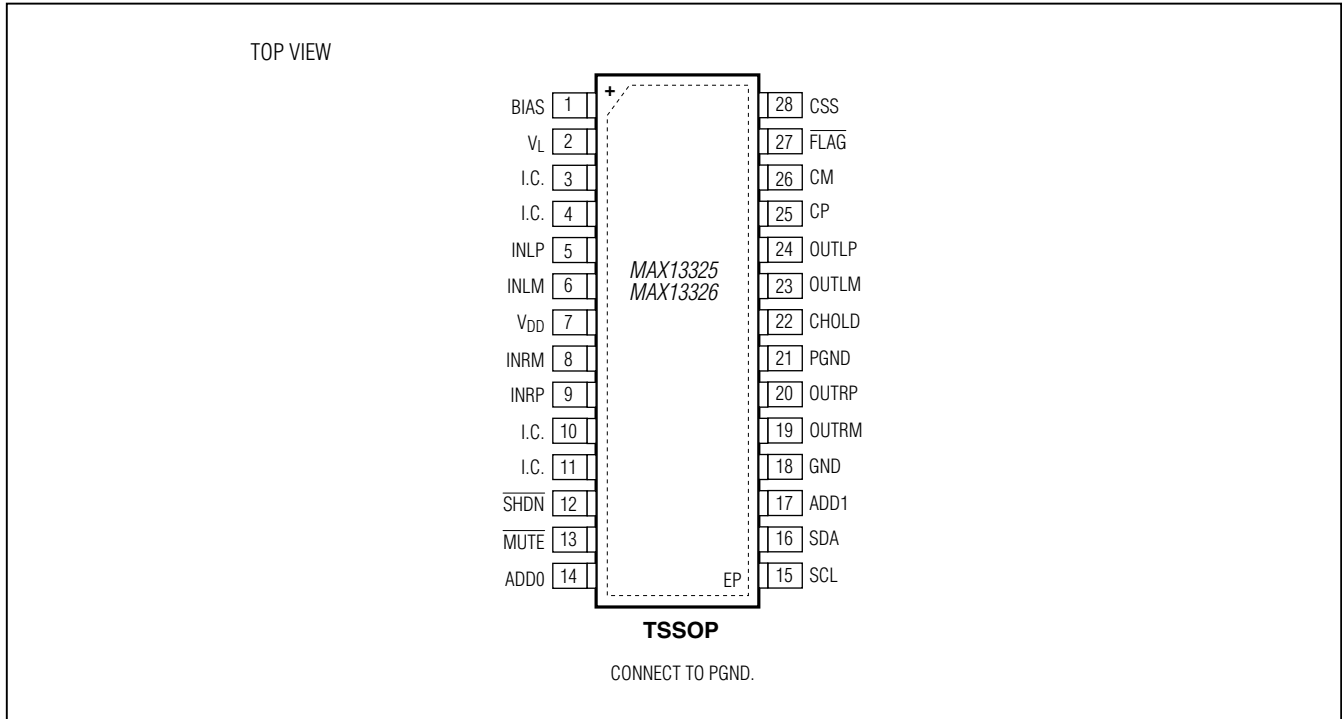

Pin Description

PIN	NAME	FUNCTION
1	BIAS	Analog Bias Voltage. Bypass BIAS to GND with a 10 μ F capacitor.
2	V _L	Logic Supply Voltage. Connect V _L to a 2.7V to 5V logic supply. Bypass V _L to GND with a 0.1 μ F capacitor.
3, 4, 10, 11	I.C.	Internally Connected. Leave unconnected.
5	INLP	Left Audio Positive Input. Either input of each pair can be used as a single-ended input, with the complementary input bypassed to GND.
6	INLM	Left Audio Negative Input. Either input of each pair can be used as a single-ended input, with the complementary input bypassed to GND.
7	V _{DD}	Power-Supply Input. Connect V _{DD} to the supply voltage. Bypass V _{DD} to GND through a 1 μ F capacitor.
8	INRM	Right Audio Negative Input. Either input of each pair can be used as a single-ended input, with the complementary input bypassed to GND.
9	INRP	Right Audio Positive Input. Either input of each pair can be used as a single-ended input, with the complementary input bypassed to GND.
12	SHDN	Shutdown Input. Drive SHDN low to power down the device.
13	MUTE	Mute Input. Drive MUTE low to mute the outputs. The outputs are low impedance in mute.

MAX13325/MAX13326

Dual Automotive, Audio Line Drivers with I²C Control and Diagnostic

Pin Description (continued)

PIN	NAME	FUNCTION
14	ADD0	I ² C Address Inputs. Connect ADD0 and ADD1 to V _L , GND, SCL, or SDA to select 7 I ² C addresses. Connect ADD0 and ADD1 to GND for stand-alone mode.
15	SCL	Serial Clock
16	SDA	Serial-Data IO
17	ADD1	I ² C Address Inputs. Connect ADD0 and ADD1 to V _L , GND, SCL, or SDA to select 7 I ² C addresses. Connect ADD0 and ADD1 to GND for stand-alone mode.
18	GND	Analog Ground. Ground connection for the input bias and gain circuits.
19	OUTRM	Right Audio Negative Output. Each output is current limited.
20	OUTRP	Right Audio Positive Output. Each output is current limited.
21	PGND	Power Ground. Ground connection for the output stage drivers.
22	CHOLD	Charge-Pump Output (When Charge Pump is On; CPOFF = 0). When the charge pump is off, provide an external supply through a diode to the CHOLD input. Bypass CHOLD with 1μF to PGND.
23	OUTLM	Left Audio Negative Output. Each output is current limited.
24	OUTLP	Left Audio Positive Outputs. Each output is current limited.
25	CP	Charge-Pump Flying Capacitor, Positive Connection
26	CM	Charge-Pump Flying Capacitor, Negative Connection
27	FLAG	Open-Drain Fault Flag Output. FLAG indicates a fault on any one channel. In stand-alone mode, FLAG is stretched to a typical pulse width of 100ms.
28	CSS	Soft-Start Capacitor Connection. CSS is charged/discharged by < 100μA current to get soft mute/play transition. Bypass to GND through a 220nF capacitor.
—	EP	Exposed Pad. Connect to PGND.

Detailed Description

The MAX13325/MAX13326 audio line drivers are designed to transmit audio data across noisy environments. The differential interface is highly resistant to noise injection from external sources common to automotive applications.

The MAX13325/MAX13326 operate in stand-alone or I²C-compatible mode with diagnostic outputs capable of detecting short to GND or battery, overcurrent, over-temperature, or excessive offset. A short across another audio output signal line is also protected.

Table 1. Register Address Map

ADDRESS	REGISTER TYPE	NAME	READ/WRITE	DEFAULT
0x00	Configuration	CONFIG	Read/Write	0x00
0x01	Command Byte	CMD	Read/Write	0x00
0x02	General Fault	GFAULT	Read	0x00
0x03	Left-Channel Fault	LFAULT	Cleared on Read	0x00
0x04	Right-Channel Fault	RFAULT	Cleared on Read	0x00
0x05	Flag	FLAG	Read	0x04 (12dB) 0x05 (0dB)
0x06	General Mask	GMASK	Read/Write	0x00
0x07	Left-Channel Mask	LMASK	Read/Write	0x00
0x08	Right-Channel Mask	RMASK	Read/Write	0x00

MAX13325/MAX13326

Dual Automotive, Audio Line Drivers with I²C Control and Diagnostic

Configuration Register

Table 2. Configuration Register Format

FUNCTION	ADDRESS CODE (HEX)	REGISTER DATA								POR STATE (HEX)
		D7	D6	D5	D4	D3	D2	D1	D0	
Configuration Register	0x00	DIAG	ENABLE	MUTE	CPOFF	OLDL	OLDR	CPF1	CPF0	0x00

DIAG: Set DIAG to 1 to enable diagnostic mode. Write '0' to disable diagnostic mode.

ENABLE: Set ENABLE bit to 1 to enable the device. Write '0' disables the device. Low on the $\overline{\text{SHDN}}$ pin overrides the ENABLE bit.

MUTE: Set the MUTE bit to 1 to mute both the output channels. Output is low impedance when in mute. Low on the $\overline{\text{MUTE}}$ pin input overrides the MUTE bit.

CPOFF: Set the CPOFF bit to 1 to turn off the charge pump. CHOLD pin must be externally supplied (see the VCPH parameter in the *Electrical Characteristics* table). Charge pump is enabled when CPOFF = 0.

OLDL: Write 1 to the OLDL bit to initiate the open-load detection for the left channel. To run OLDL again, write '0' and '1' again.

OLDR: Write 1 to the OLDR bit to initiate the open-load detection for the right channel. To run OLDR again, write '0' and '1' again.

Table 2a. Charge-Pump Frequency Bits

CPF1	CPF0	FREQUENCY (kHz)
0	0	333
0	1	190
1	0	426
1	1	260

CPF[1:0]: Sets the frequency of the charge pump.

Command Byte Register

Table 3. Command Byte Register Format

FUNCTION	ADDRESS CODE (HEX)	REGISTER DATA								POR STATE (HEX)
		D7	D6	D5	D4	D3	D2	D1	D0	
Command Byte Register	0x01	RETRYL	RETRYR	x	x	x	x	x	x	0x00

RETRYR: The right-channel power amplifier switches off after a fault condition. Write '1' to turn it back on after the fault condition.

RETRYL: The left-channel power amplifier switches off after a fault condition. Write '1' to turn on the left-channel power amplifier after the fault condition.

MAX13325/MAX13326

Dual Automotive, Audio Line Drivers with I²C Control and Diagnostic

General Faults

Table 4. General Fault Register Format

FUNCTION	ADDRESS CODE (HEX)	REGISTER DATA								POR STATE (HEX)
		D7	D6	D5	D4	D3	D2	D1	D0	
General Fault Register	0x02	x	TWARN	TSHDN	DUMP	x	x	x	x	0x00

TWARN: The TWARN bit is set to '1' when the temperature warning threshold is reached.

TSHDN: The TSHDN is set to '1' when the temperature shutdown threshold is reached.

DUMP: The DUMP bit is set to '1' when the V_{DD} voltage exceeds the overvoltage threshold.

Set the appropriate mask bit in the GMASK register to detect the general faults. See Table 8.

Left-Channel Faults

Table 5. Left-Channel Fault Register Format

FUNCTION	ADDRESS CODE (HEX)	REGISTER DATA								POR STATE (HEX)
		D7	D6	D5	D4	D3	D2	D1	D0	
Left-Channel Fault Register	0x03	SVDDL	SGNDL	LIMITL	x	OFFSETL	OPENL	x	x	0x00

SVDDL: The SVDDL bit is set to '1' when a short to V_{DD} is detected on the left channel.

SGNDL: The SGNDL bit is set to '1' when a short to GND is detected on the left channel.

LIMITL: The LIMITL bit is set to '1' when the current-limit threshold is tripped for left output.

OFFSETL: The OFFSETL bit is set to '1' when excessive offset is detected on the left-channel output.

OPENL: The OPENL bit is set to '1' when an open load is detected on the left channel.

Set the appropriate mask bit in the LMASK register to detect the faults on the left channel. See Table 9.

When any bit of the LFAULT register is high, the $\overline{\text{FLAG}}$ output is low.

Right-Channel Faults

Table 6. Right-Channel Fault Register Format

FUNCTION	ADDRESS CODE (HEX)	REGISTER DATA								POR STATE (HEX)
		D7	D6	D5	D4	D3	D2	D1	D0	
Right-Channel Fault Register	0x04	SVDDR	SGNDR	LIMITR	x	OFFSETR	OPENR	x	x	0x00

SVDDR: The SVDDR bit is set to '1' when a short to V_{DD} is detected on the right channel.

SGNDR: The SGNDR bit is set to '1' when a short to GND is detected on the right channel.

LIMITR: The LIMITR bit is set to '1' when the current-limit threshold is tripped for right output.

OFFSETR: The OFFSETR bit is set to '1' when excessive offset is detected on the right-channel output.

OPENR: The OPENR bit is set to '1' when an open load is detected on the right channel.

Set the appropriate mask bit in the RMASK register to detect the faults on the right channel. See Table 10.

When any bit of the RFAULT register is high, the $\overline{\text{FLAG}}$ output is pulled low.

MAX13325/MAX13326

Dual Automotive, Audio Line Drivers with I²C Control and Diagnostic

FLAG Register

Table 7. Flag Register Format

FUNCTION	ADDRESS CODE (HEX)	REGISTER DATA								POR STATE (HEX)
		D7	D6	D5	D4	D3	D2	D1	D0	
FLAG Register	0x05	FLAG	LHIGHZ	RHIGHZ	OFFSETL	OFFSETR	ID2	ID1	ID0	0x04/0x05

FLAG: FLAG bit is set to '1' when the $\overline{\text{FLAG}}$ output is logic-low. The FLAG bit allows to quickly access the status of the device without using the $\overline{\text{FLAG}}$ output and without having to read all the fault registers.

LHIGHZ: The LHIGHZ bit is set to '1' when the left-channel output is high impedance; for example due to a short circuit.

RHIGHZ: The RHIGHZ bit is set to '1' when the right-channel output is high impedance; for example due to a short circuit.

OFFSETL: The OFFSETL bit is set to '1' when excessive offset is detected on the left-channel output.

OFFSETR: The OFFSETR bit is set to '1' when excessive offset is detected on the right-channel output.

ID[2:0]: The ID[2:0] bits indicate the device type (12dB = 100 and 0dB = 101).

General Mask Register

Table 8. General Mask Register Format

FUNCTION	ADDRESS CODE (HEX)	REGISTER DATA								POR STATE (HEX)
		D7	D6	D5	D4	D3	D2	D1	D0	
General Mask Register	0x06	0	MTWARN	MTSHDN	MDUMP	x	x	x	x	0x00

MTWARN: Set MTWARN to '1' to enable the TWARN fault detection. See Table 4.

MTSHDN: Set MTSHDN to '1' to enable the TSHDN fault detection. See Table 4.

MDUMP: Set MDUMP to '1' to enable the DUMP fault detection. See Table 4.

Left-Channel Mask Register

Table 9. Left-Channel Mask Register

FUNCTION	ADDRESS CODE (HEX)	REGISTER DATA								POR STATE (HEX)
		D7	D6	D5	D4	D3	D2	D1	D0	
Left-Channel Mask Register	0x07	MSVDDL	MSGNDL	MLIMITL	0	MOFFSETL	MOPENL	x	x	0x00

MSVDDL: Set MSVDDL to 1 to enable the short to V_{DD} detection on the left channel.

MSGNDL: Set MSGNDL to 1 to enable the short to GND detection on the left channel.

MLIMITL: Set MLIMITL to 1 to enable overcurrent detection on the left channel.

MOFFSETL: Set MOFFSETL to 1 to enable excessive-offset detection on the left-channel output.

MOPENL: Set MOPENL to 1 to enable open-load detection on the left channel.

MAX13325/MAX13326

Dual Automotive, Audio Line Drivers with I²C Control and Diagnostic

Right-Channel Mask Register

Table 10. Right-Channel Mask Register

FUNCTION	ADDRESS CODE (HEX)	REGISTER DATA								POR STATE (HEX)
		D7	D6	D5	D4	D3	D2	D1	D0	
Right-Channel Mask Register	0x08	MSVDDR	MSGNDR	MLIMITR	0	MOFFSETR	MOPENR	x	x	0x00

MSVDDR: Set MSVDDR to 1 to enable the short to V_{DD} detection on the right channel.

MSGNDR: Set MSGNDR to 1 to enable the short to GND detection on the right channel.

MLIMITR: Set MLIMITR to 1 to enable overcurrent detection on the right channel.

MOFFSETR: Set MOFFSETR to 1 to enable excessive-offset detection on the right channel.

MOPENR: Set MOPENR to 1 to enable open-load detection on the right channel.

I²C and Stand-Alone Diagnostics

When the DIAG bit and the appropriate mask bits are set to 1, the MAX13325/MAX13326 enter diagnostic mode. In this mode, the MAX13325/MAX13326 detect short to GND, short to battery, overcurrent condition, over-temperature condition, excessive offset, and report the diagnosis using the I²C serial interface, FLAG bit, and the FLAG output.

For stand-alone mode, there exists a 500ms stand-alone fault retry function (for autoretry) until the fault goes away. The $\overline{\text{FLAG}}$ output is pulsed to indicate a fault.

Output Short to V_{DD}

When in diagnostic mode, the MAX13325/MAX13326 detect if any of the differential outputs is shorted to V_{DD} or battery. Upon detection of the short to V_{DD} or battery, the faulted channel is switched off and its output goes into a high-impedance state. The fault is reported using the I²C interface and the $\overline{\text{FLAG}}$ output. See Table 11.

Table 11. Output Short to V_{DD}/Battery Diagnostic

FAULT CONDITION	STATUS REPORT	UNMASK	RECOVERY
Left-Channel Output Short to V _{DD}	$\overline{\text{FLAG}}$ is asserted low.	In LMASK register, set MSVDDL bit to 1. See Table 9.	Cleared on reading the LFAULT register. See Table 5. Note: 500ms autoretry in stand-alone mode.
	FLAG bit set. See Table 7.		
	SVDDL bit is set in the LFAULT register. See Table 5.		
	Left channel switches off and output goes to high-impedance state.	Cannot be masked.	Output is enabled by setting the RETRYL bit to 1 in the Common Byte register. See Table 3.
Right-Channel Output Short to V _{DD}	$\overline{\text{FLAG}}$ is asserted low.	In RMASK register, set MSVDDR bit to 1. See Table 10.	Cleared on reading the RFAULT register. See Table 6. Note: 500ms autoretry in stand-alone mode.
	FLAG bit set. See Table 7.		
	SVDDR bit is set in the RFAULT register. See Table 6.		
	Right channel switches off and output goes to high-impedance state.	Cannot be masked.	Output is enabled by setting the RETRYR bit to 1 in the Command Byte register. See Table 3.

MAX13325/MAX13326

Dual Automotive, Audio Line Drivers with I²C Control and Diagnostic

Output Short to GND

When in diagnostic mode, the MAX13325/MAX13326 detect if any of the differential outputs is shorted to ground. Upon detection of the short to ground, the faulted channel is switched off and its output goes into a high-impedance state. The fault is reported using the I²C interface and the $\overline{\text{FLAG}}$ output. See Table 12.

Overtemperature

When in diagnostic mode, if the MAX13325/MAX13326 exceed the overtemperature warning or temperature shutdown thresholds the device reports the condition using the I²C interface and the $\overline{\text{FLAG}}$ output. See Table 13.

Table 12. Output Short to GND Diagnostic

FAULT CONDITION	STATUS REPORT	UNMASK	RECOVERY
Left-Channel Output Short to GND	$\overline{\text{FLAG}}$ is asserted low.	In LMASK register, set MSGNDL bit to 1. See Table 9.	Cleared on reading the LFAULT register. See Table 5. Note: 500ms autoretry in stand-alone mode.
	FLAG bit set. See Table 7.		
	SGNDL bit is set in the LFAULT register. See Table 5.		
	Left channel switches off and output goes to high-impedance state.		
Right-Channel Output Short to GND	$\overline{\text{FLAG}}$ is asserted low.	In RMASK register, set MSGNDR bit to 1. See Table 10.	Cleared on reading the RFAULT register. See Table 6. Note: 500ms autoretry in stand-alone mode.
	FLAG bit set. See Table 7.		
	SGNDR bit is set in the RFAULT register. See Table 6.		
	Right channel switches off and output goes to high-impedance state.		

Table 13. Overtemperature Diagnostic

FAULT CONDITION	STATUS REPORT	UNMASK	RECOVERY
Overtemperature Warning	$\overline{\text{FLAG}}$ is asserted low.	In GMASK register, set MTWARN bit to 1. See Table 8.	Die temperature falls below warning threshold. Cleared on reading the GFAULT register.
	FLAG bit set. See Table 7.		
	TWARN bit is set in the GFAULT register. See Table 4.		
Overtemperature Shutdown	$\overline{\text{FLAG}}$ is asserted low.	In GMASK register, set MTSHDN bit to 1. See Table 8.	Die temperature falls below shutdown threshold. Cleared on reading the GFAULT register. Note: 500ms autoretry in stand-alone mode.
	FLAG bit set. See Table 7.		
	TSHDN bit is set in the GFAULT Register. See Table 4.		
	Left and right channels switch off and output goes to high-impedance state.		

MAX13325/MAX13326

Dual Automotive, Audio Line Drivers with I²C Control and Diagnostic

Excessive Offset

When in diagnostic mode with mute enabled, if there is excessive offset on any output, the MAX13325/MAX13326 reports the condition through the I²C interface and the $\overline{\text{FLAG}}$ output. See Table 14.

Overcurrent

When in diagnostic mode, if any of the output pairs is excessively loaded, the MAX13325/MAX13326 issue a warning and report the condition through the I²C interface and the $\overline{\text{FLAG}}$ output. The faulted channel is not switched off. See Table 15.

Open Load

When in diagnostic mode and the open-load detection is initiated, the selected channel is switched off for 1ms during which the diagnosis is taking place. Upon detecting an open load on any channel, the MAX13325/MAX13326 report the condition using the I²C interface and the $\overline{\text{FLAG}}$ output. See Table 16.

Overvoltage

When in diagnostic mode, if the MAX13325/MAX13326 exceed the V_{DD} overvoltage threshold (for example during a load-dump condition), the device reports the condition using the I²C interface and the $\overline{\text{FLAG}}$ output. See Table 17.

Table 14. Excessive Offset Diagnostic

FAULT CONDITION	STATUS REPORT	UNMASK	RECOVERY
Excessive Output Offset on Left Channel	$\overline{\text{FLAG}}$ is asserted low.	In the LMASK register, set MOFFSETL bit to 1. See Table 9.	Cleared on reading the LFAULT register.
	FLAG bit set. See Table 7.		
	OFFSETL bit is set in the LFAULT register. See Table 5.		
Excessive Output Offset on Right Channel	$\overline{\text{FLAG}}$ is asserted low.	In the RMASK register, set MOFFSETR bit to 1. See Table 10.	Cleared on reading the RFAULT register.
	FLAG bit set.		
	OFFSETR bit is set in the RFAULT register. See Table 6.		

Table 15. Overcurrent Diagnostic

FAULT CONDITION	STATUS REPORT	UNMASK	RECOVERY
Overcurrent on Left Channel	$\overline{\text{FLAG}}$ is asserted low.	In the LMASK register, set MLIMITL bit to 1. See Table 9.	Load current falls below the current-limit threshold. Cleared on reading the LFAULT register.
	FLAG bit set. See Table 7.		
	LIMITL bit is set in the LFAULT register. See Table 5.		
Overcurrent on Right Channel	$\overline{\text{FLAG}}$ is asserted low.	In the RMASK register, set MLIMITR bit to 1. See Table 10.	Load current falls below the current-limit threshold. Cleared on reading the RFAULT register.
	FLAG bit set. See Table 7.		
	LIMITR bit is set in the RFAULT register. See Table 6.		

Table 16. Open-Load Diagnostic

FAULT CONDITION	STATUS REPORT	UNMASK	RECOVERY
Left-Channel Open Load	$\overline{\text{FLAG}}$ is asserted low.	In the LMASK register, set MOPENL bit to 1. See Table 9.	Cleared on reading the LFAULT register.
	FLAG bit set. See Table 7.		
	OPENL bit is set in the LFAULT register. See Table 5.		
Right-Channel Open Load	$\overline{\text{FLAG}}$ is asserted low.	In the RMASK register, set MOPENR bit to 1. See Table 10.	Cleared on reading the RFAULT register.
	FLAG bit set. See Table 7.		
	OPENR bit is set in the RFAULT register. See Table 6.		

MAX13325/MAX13326

Dual Automotive, Audio Line Drivers with I²C Control and Diagnostic

Table 17. Overvoltage Diagnostic

FAULT CONDITION	STATUS REPORT	UNMASK	RECOVERY
Overvoltage Shutdown	$\overline{\text{FLAG}}$ is asserted low.	In GMASK register, set MDUMP bit to 1. See Table 8.	V _{DD} voltage falls below overvoltage threshold. Cleared on reading the GFAULT register. Note: 500ms autoretry in stand-alone mode.
	FLAG bit set. See Table 7.		
	DUMP bit is set in the GFAULT register. See Table 4.		
	Left and right channels switch off and output goes to a high-impedance state.	Cannot be masked.	Left channel is enabled by setting the RETRYL bit to 1. Right channel is enabled by setting the RETRYR bit to 1. See Table 3.

Applications Information

Serial Interface

Writing to the MAX13325/MAX13326 using I²C requires that first the master sends a START (S) condition followed by the device's I²C address. After the address, the master sends the register address of the register that is to be programmed. The master then ends communication by issuing a STOP (P) condition to relinquish

control of the bus, or a Repeated START (Sr) condition to communicate to another I²C slave (see Figure 1).

Bit Transfer

Each SCL rising edge transfers one data bit. The data on SDA must remain stable during the high portion of the SCL clock pulse (see Figure 2). Changes in SDA while SCL is high are read as control signals (see the *START and STOP Conditions* section). When the serial interface is inactive, SDA and SCL idle high.

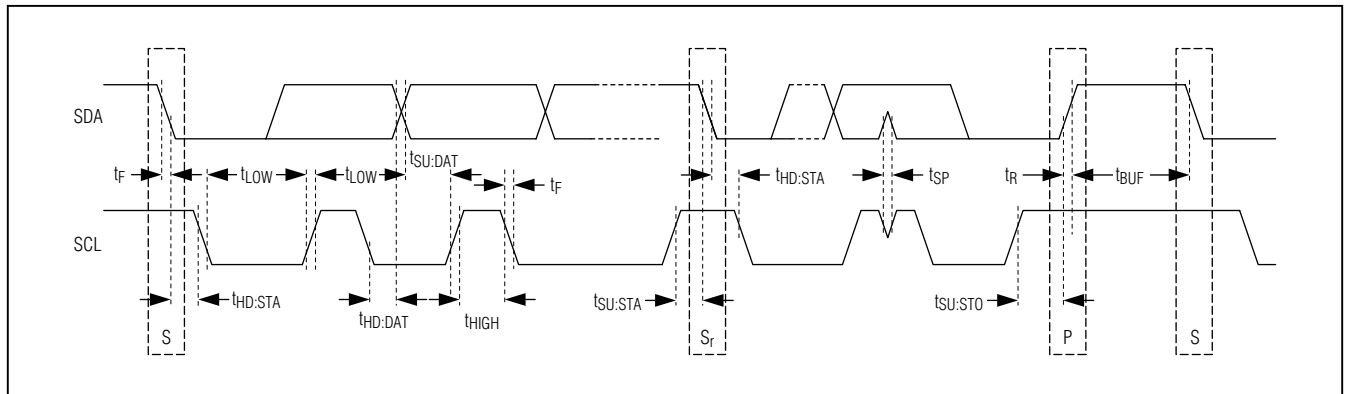

Figure 1. I²C Timing

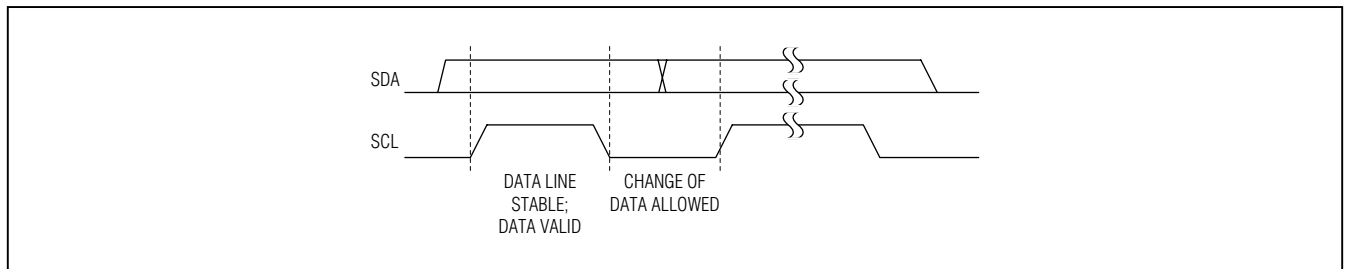

Figure 2. Bit Transfer

MAX13325/MAX13326

Dual Automotive, Audio Line Drivers with I²C Control and Diagnostic

START and STOP Conditions

A master device initiates communication by issuing a START condition, which is a high-to-low transition on SDA with SCL high. A START condition from the master signals the beginning of a transmission to the MAX13325/MAX13326. The master terminates transmission by a STOP condition (see the *Acknowledge Bit* section). A STOP condition is a low-to-high transition on SDA while SCL is high (Figure 3). The STOP condition frees the bus. If a Repeated START condition is generated instead of a STOP condition, the bus remains active. When a STOP condition or incorrect slave ID is detected, the device internally disconnects SCL from the

serial interface until the next START or Repeated START condition, minimizing digital noise and feedthrough.

Acknowledge Bit

The acknowledge (ACK) bit is a clocked 9th bit that the MAX13325/MAX13326 use to handshake receipt of each byte of data when in write mode. The MAX13325/MAX13326 pull down SDA during the entire master-generated 9th clock pulse if the previous byte is successfully received (see Figure 4). Monitoring ACK allows for detection of unsuccessful data transfers. An unsuccessful data transfer occurs if a receiving device is busy or if a system fault has occurred. In the event

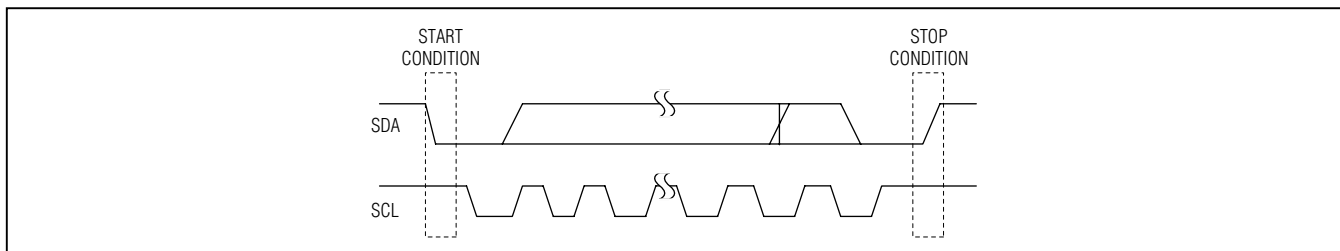

Figure 3. START/STOP Conditions

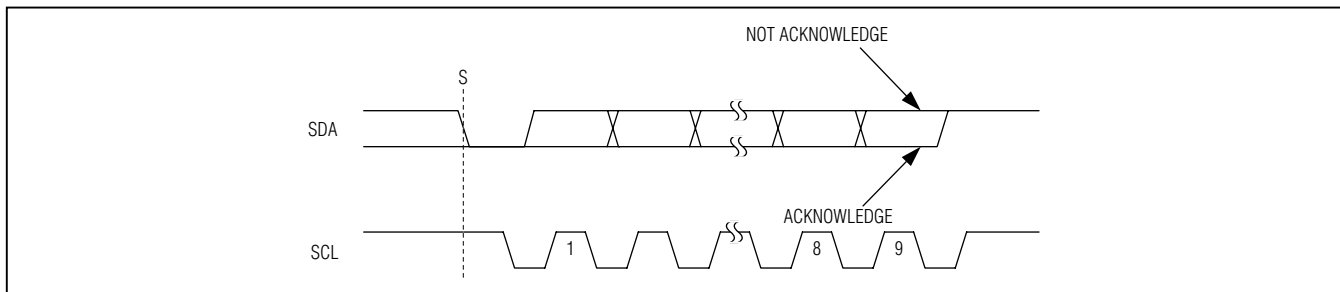

Figure 4. Acknowledge and Not-Acknowledge Bits

Table 18. Slave Address

ADD1	ADD0	A6	A5	A4	A3	A2	A1	A0	R/W	SLAVE ADDRESS READ (HEX)	SLAVE ADDRESS WRITE (HEX)	MODE
GND	GND	—	—	—	—	—	—	—	—	—	—	Stand-alone
V _L	GND	1	1	0	0	0	0	1	1/0	0xC3	0xC2	I ² C
GND	V _L	1	1	0	0	0	1	0	1/0	0xC5	0xC4	I ² C
V _L	V _L	1	1	0	0	0	1	1	1/0	0xC7	0xC6	I ² C
SCL	V _L	1	1	0	0	1	0	0	1/0	0xC9	0xC8	I ² C
SDA	V _L	1	1	0	0	1	0	1	1/0	0xCB	0xCA	I ² C
V _L	SCL	1	1	0	0	1	1	0	1/0	0xCD	0xCC	I ² C
V _L	SDA	1	1	0	0	1	1	1	1/0	0xCF	0xCE	I ² C

MAX13325/MAX13326

Dual Automotive, Audio Line Drivers with I²C Control and Diagnostic

of an unsuccessful data transfer, the bus master may retry communication. The master must pull down SDA during the 9th clock cycle to acknowledge receipt of data when the MAX13325/MAX13326 are in read mode. An acknowledge must be sent by the master after each read byte to allow data transfer to continue. A not-acknowledge is sent when the master reads the final byte of data from the MAX13325/MAX13326, followed by a STOP condition.

Slave Address

The MAX13325/MAX13326 are programmable to one of seven I²C slave addresses. These slave addresses are unique device IDs. Connect ADD₀ to GND, V_L, SCL, or SDA to set the I²C slave address. The address is defined as the seven most significant bits (MSBs) followed by the read/write bit. Set the read/write bit to 1 to configure the MAX13325/MAX13326 to read mode. Set the read/write bit to 0 to configure the device to write mode. The address is the first byte of information sent after the START condition.

Register Address Map

Single-Byte Write Operation

For a single-byte write operation, send the slave address as the first byte followed by the register address and then a single data byte (see Figure 5).

Burst Write Operation

For a burst write operation, send the slave address as the first byte followed by the register address and then the data bytes (see Figure 6).

Single-Byte Read Operation

For a single-byte read operation, send the slave address with the read bit set, as the first byte followed by the register address. Then send a Repeated START condition followed by the slave address. After the slave sends the data byte, send a not-acknowledge followed by a STOP condition (see Figure 7).

Burst Read Operation

For a burst read operation, send the slave address with a write as the first byte followed by the register address. Then send a Repeated START condition followed by the slave address. The slave sends data bytes until a not-acknowledge condition is sent (see Figure 8).

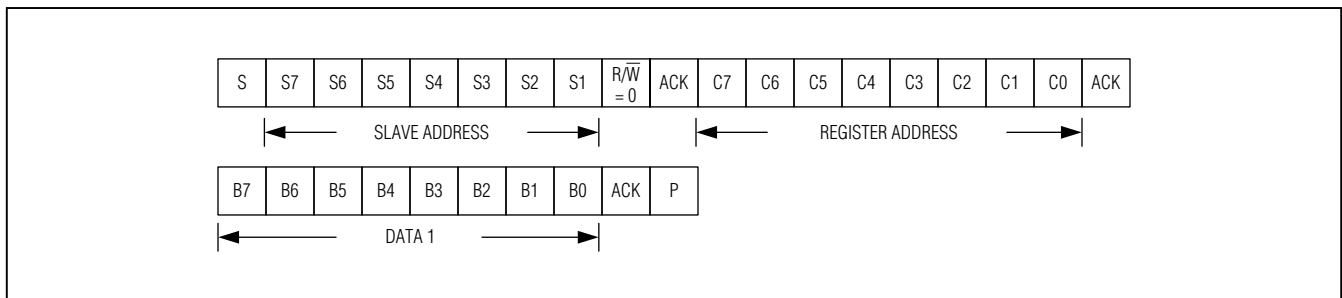

Figure 5. A Single-Byte Write Operation

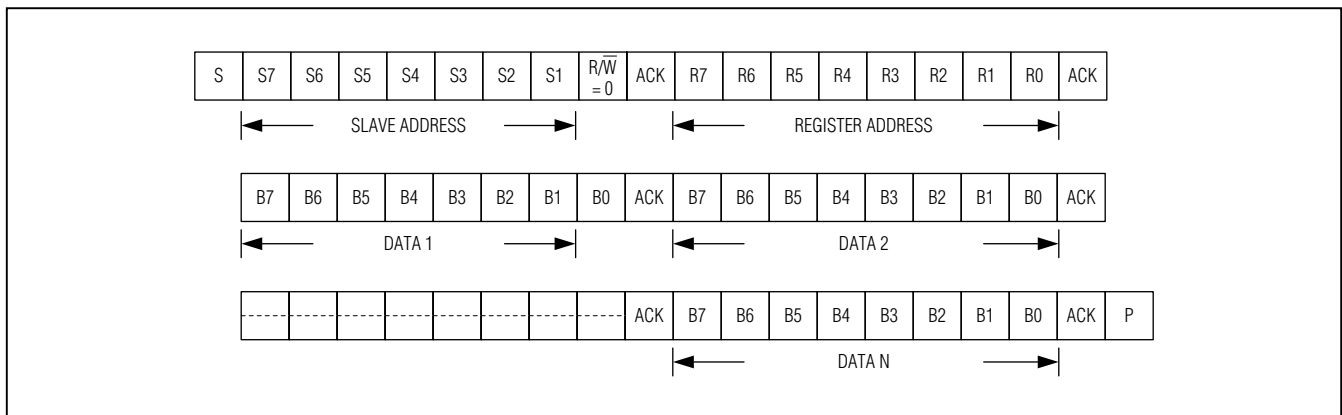

Figure 6. A Burst Write Operation

MAX13325/MAX13326

Dual Automotive, Audio Line Drivers with I²C Control and Diagnostic

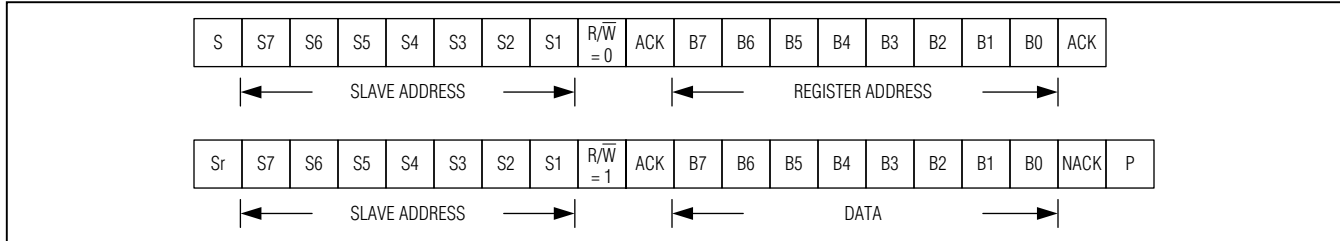

Figure 7. A Single-Byte Read Operation

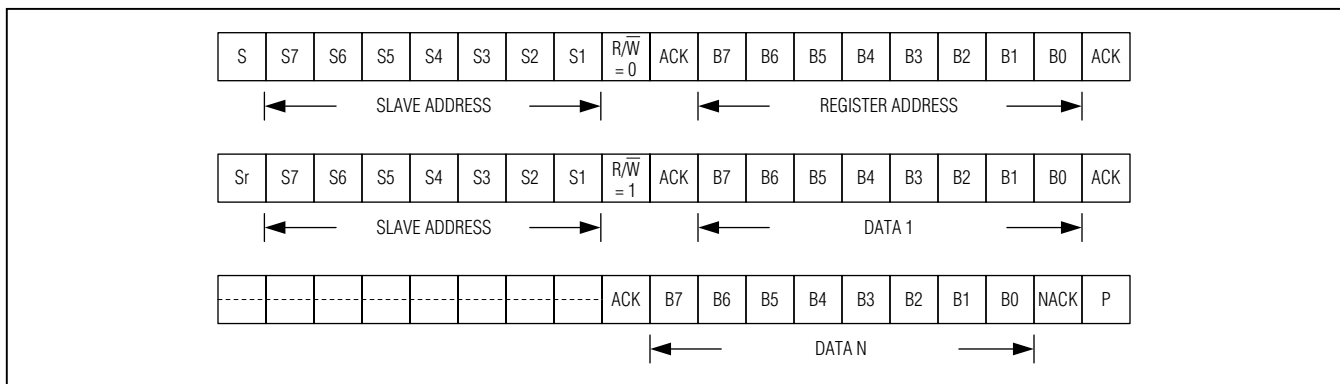

Figure 8. A Burst Read Operation

Charge Pump

The MAX13325/MAX13326 charge pump can be disabled depending on application requirements. When charge pump is enabled [CPOFF = 0], please follow the charge-pump capacitor selections. When the charge pump is disabled [CPOFF = 1], the flying capacitor (C1) is not needed. There are internal diodes between VDD/OUT_ to CHOLD, so it is important that CHOLD not be forced below VDD or any of the outputs. A series diode needs to be placed between the external supply (VSUP) and CHOLD. See D2 in the *Typical Operating Circuit*.

Charge-Pump Capacitor Selection

Use ceramic capacitors with a low ESR for optimum performance. For optimal performance over the extended temperature range, select capacitors with an X7R dielectric. Table 19 lists suggested manufacturers.

Flying Capacitor (C1)

The value of the flying capacitor (see the *Typical Operating Circuit*) affects the charge pump's load regulation and output resistance. A C1 value that is too small degrades the device's ability to provide sufficient current drive, which leads to a loss of output voltage. Increasing the value of C1 improves load regulation and reduces the charge-pump output resistance. For optimum performance, use a 470nF capacitor for C1. When the charge pump is disabled [CPOFF = 1], the flying capacitor (C1) is not needed.

Hold Capacitor (C2)

The hold capacitor value (see the *Typical Operating Circuit*) and ESR directly affect the ripple at the internal negative rail. Increasing the value of C2 reduces output ripple. Likewise, decreasing the ESR of C2 reduces both ripple and output resistance. Lower capacitance values can be used in systems with low maximum output power levels. For optimum performance, use a 1µF capacitor for C2.

Table 19. Suggested Capacitor Vendors

SUPPLIER	PHONE	FAX	WEBSITE
Murata Electronics North America, Inc.	770-436-1300	770-436-3030	www.murata-northamerica.com
Taiyo Yuden	800-348-2496	847-925-0899	www.t-yuden.com
TDK Corp.	847-803-6100	847-390-4405	www.component.tdk.com

MAX13325/MAX13326

Dual Automotive, Audio Line Drivers with I²C Control and Diagnostic

Power-Supply Bypass Capacitor (C3)

The power-supply bypass capacitor (see the *Typical Operating Circuit*) lowers the output impedance of the power supply, and reduces the impact of the MAX13325/MAX13326 charge-pump switching transients. Bypass V_{DD} with C3, the same value as C2, and place it physically close to the V_{DD} and PGND pins.

Load-Dump Protection

With minimal external components, the MAX13325/MAX13326 can be protected against automotive load-dump conditions. See the *Typical Operating Circuit*.

nMOSFET (Q1)

Q1 should be selected to withstand the full-voltage exposure (BV_{DSS} > 45V). The gate-source turn-on voltage should be chosen to be less than V_{CPS} to ensure initial startup. Using an external nMOS, RTR020N05, 300ms duration component provides 50V load-dump protection.

Zener Diode (D1)

During short-to-battery condition, OUT_ lifts up CHOLD using an internal diode. In order not to violate the maximum gate-source voltage of Q1, a zener diode of appropriate clamping voltage should be added between the gate and source terminals.

Series Resistor (R1)

Normally, a series resistor for current limitation is needed during short-to-battery condition. R1 should be chosen according to $(18V - V_{DD(min)} - V_{ZENER})/1mA$ so that no excessive current is being drawn from CHOLD.

Layout and Grounding

Proper layout and grounding are essential for optimum performance. Connect the EP and GND together at a single point on the PCB. Ensure ground return resistance is minimized for optimum crosstalk performance.

Chip Information

PROCESS: BCD

Package Information

For the latest package outline information and land patterns (footprints), go to www.maximintegrated.com/packages. Note that a "+", "#", or "-" in the package code indicates RoHS status only. Package drawings may show a different suffix character, but the drawing pertains to the package regardless of RoHS status.

PACKAGE TYPE	PACKAGE CODE	OUTLINE NO.	LAND PATTERN NO.
28 TSSOP-EP	U28E+5	21-0108	90-0147

MAX13325/MAX13326

Dual Automotive, Audio Line Drivers with I²C Control and Diagnostic

Revision History

REVISION NUMBER	REVISION DATE	DESCRIPTION	PAGES CHANGED
0	1/10	Initial release	—
1	3/10	Updated the <i>Typical Operating Circuit</i>	1
2	4/10	Added new register bits to Tables 1, 2, and 7. Revised <i>FLAG Register</i> section and added Table 2a and <i>Charge Pump</i> section.	1, 4, 7, 8–12, 19, 20
3	6/10	Introduced the MAX13326. Updated the <i>Electrical Characteristics</i> table and added new <i>Typical Operating Characteristics</i> graphs.	1, 4, 5, 7
4	9/12	Corrected slave addresses in Table 18	17
5	4/13	Corrected bits D[7:6] in Table 3	10



Maxim Integrated cannot assume responsibility for use of any circuitry other than circuitry entirely embodied in a Maxim Integrated product. No circuit patent licenses are implied. Maxim Integrated reserves the right to change the circuitry and specifications without notice at any time. The parametric values (min and max limits) shown in the Electrical Characteristics table are guaranteed. Other parametric values quoted in this data sheet are provided for guidance.