

## 阅读申明

- 1.本站收集的数据手册和产品资料都来自互联网，版权归原作者所有。如读者和版权方有任何异议请及时告之，我们将妥善解决。
- 2.本站提供的中文数据手册是英文数据手册的中文翻译，其目的是协助用户阅读，该译文无法自动跟随原稿更新，同时也可能存在翻译上的不当。建议读者以英文原稿为参考以便获得更精准的信息。
- 3.本站提供的产品资料，来自厂商的技术支持或者使用者的心得体会等，其内容可能存在描述上的差异，建议读者做出适当判断。
- 4.如需与我们联系，请发邮件到marketing@iczoom.com，主题请标有“数据手册”字样。

## Read Statement

1. The datasheets and other product information on the site are all from network reference or other public materials, and the copyright belongs to the original author and original published source. If readers and copyright owners have any objections, please contact us and we will deal with it in a timely manner.
2. The Chinese datasheets provided on the website is a Chinese translation of the English datasheets. Its purpose is for reader's learning exchange only and do not involve commercial purposes. The translation cannot be automatically updated with the original manuscript, and there may also be improper translations. Readers are advised to use the English manuscript as a reference for more accurate information.
3. All product information provided on the website refer to solutions from manufacturers' technical support or users the contents may have differences in description, and readers are advised to take the original article as the standard.
4. If you have any questions, please contact us at marketing@iczoom.com and mark the subject with "Datasheets" .

## FEATURES

### APIX2 receiver with HDCP

High-bandwidth Digital Content Protection (HDCP) 1.4 support with internal preprogrammed HDCP keys HDCP decryption of video and audio

HDCP repeater support

Supports 2 independent video streams

One TDM channel with support for up to 4 stereo pairs

Up to 3000 Mbps sustained downstream link bandwidth

Up to 187.5 Mbps upstream link bandwidth

Media independent interface (MII), serial port interface (SPI), I<sup>2</sup>C, and GPIO interfaces for sideband communication

### LVDS receiver (OpenLDI)

85 MHz maximum clock frequency

Maximum resolution supported is WXGA

Supports receiving video in both 24-bit mode over 4 differential pairs, and 18-bit mode over 3 differential pairs

### Dual MIPI CSI 2.0 transmitters

MIPI-A: clock and 4 data lanes

MIPI-B: clock and 2 data lanes

### Video processing

Color space conversion

4:2:2 to 4:4:4 interpolation

### Software driver

MISRA-C compliant software driver for automotive acceptability

### General

Qualified for automotive applications

-40°C to +85°C temperature grade

100-ball, 9 mm × 9 mm, RoHS-compliant CSP\_BGA package

## APPLICATIONS

Automotive high end head unit

Automotive infotainment

Portable devices

The approved use of the **ADV7782** device is limited to use cases where the **ADV7782** data output is directly input to a processing unit

## GENERAL DESCRIPTION

The **ADV7782** is a receiver that is compatible with an APIX<sup>®</sup> or APIX2<sup>®</sup> serial data stream. The **ADV7782** performs limited processing (color space conversion and interpolation 4:2:2 to 4:4:4), and forwards the data via MIPI<sup>®</sup> camera serial interface (CSI). Data from the LVDS input (OpenLDI) can also be routed through the same processing blocks. It supports a point-to-point connection topology, and supports HDCP repeater implementations with a key selection vector (KSV) list memory of 25 entries.

There are three primary video sources: LVDS OpenLDI, APIX Channel 0, and APIX Channel 1. These three primary video streams are input to a video switch matrix. Any two of the three streams can be selected and output from the switch matrix.

Of the two video channels output from the video switch matrix, one output channel is unprocessed, and the other output channel passes through a combination of an interpolation block (4:2:2 to 4:4:4) and a color space converter.

For more information about the **ADV7782**, including the complete data sheet, contact your local Analog Devices, Inc., sales office at [www.analog.com/sales](http://www.analog.com/sales).

## FUNCTIONAL BLOCK DIAGRAM

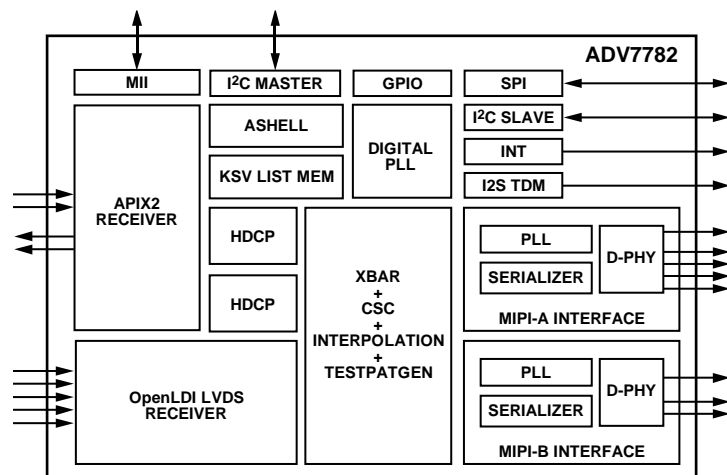

Figure 1.

Rev. SpA

[Document Feedback](#)

Information furnished by Analog Devices is believed to be accurate and reliable. However, no responsibility is assumed by Analog Devices for its use, nor for any infringements of patents or other rights of third parties that may result from its use. Specifications subject to change without notice. No license is granted by implication or otherwise under any patent or patent rights of Analog Devices. Trademarks and registered trademarks are the property of their respective owners.

One Technology Way, P.O. Box 9106, Norwood, MA 02062-9106, U.S.A.  
Tel: 781.329.4700 ©2014 Analog Devices, Inc. All rights reserved.  
[Technical Support](#) [www.analog.com](http://www.analog.com)

# ADV7782\* PRODUCT PAGE QUICK LINKS

Last Content Update: 02/23/2017

---

## COMPARABLE PARTS

View a parametric search of comparable parts.

## DOCUMENTATION

### Data Sheet

- ADV7782: APIX2 Receiver with LVDS, HDCP, and MIPI Support Data Sheet

## DESIGN RESOURCES

- ADV7782 Material Declaration
- PCN-PDN Information
- Quality And Reliability
- Symbols and Footprints

## DISCUSSIONS

View all ADV7782 EngineerZone Discussions.

## SAMPLE AND BUY

Visit the product page to see pricing options.

## TECHNICAL SUPPORT

Submit a technical question or find your regional support number.

## DOCUMENT FEEDBACK

Submit feedback for this data sheet.

---

**NOTES**

APIX® is a registered mark of INOVA Semiconductors GmbH.

I<sup>2</sup>C refers to a communications protocol originally developed by Philips Semiconductors (now NXP Semiconductors).