

阅读申明

- 1.本站收集的数据手册和产品资料都来自互联网，版权归原作者所有。如读者和版权方有任何异议请及时告之，我们将妥善解决。
- 2.本站提供的中文数据手册是英文数据手册的中文翻译，其目的是协助用户阅读，该译文无法自动跟随原稿更新，同时也可能存在翻译上的不当。建议读者以英文原稿为参考以便获得更精准的信息。
- 3.本站提供的产品资料，来自厂商的技术支持或者使用者的心得体会等，其内容可能存在描述上的差异，建议读者做出适当判断。
- 4.如需与我们联系，请发邮件到marketing@iczoom.com，主题请标有“数据手册”字样。

Read Statement

1. The datasheets and other product information on the site are all from network reference or other public materials, and the copyright belongs to the original author and original published source. If readers and copyright owners have any objections, please contact us and we will deal with it in a timely manner.
2. The Chinese datasheets provided on the website is a Chinese translation of the English datasheets. Its purpose is for reader's learning exchange only and do not involve commercial purposes. The translation cannot be automatically updated with the original manuscript, and there may also be improper translations. Readers are advised to use the English manuscript as a reference for more accurate information.
3. All product information provided on the website refer to solutions from manufacturers' technical support or users the contents may have differences in description, and readers are advised to take the original article as the standard.
4. If you have any questions, please contact us at marketing@iczoom.com and mark the subject with "Datasheets" .



Integrated Device Technology

High-Performance, Low-Phase Noise Clocks Buffers

POWER MANAGEMENT | ANALOG & RF | INTERFACE & CONNECTIVITY | CLOCKS & TIMING | MEMORY & LOGIC | TOUCH & USER INTERFACE | VIDEO & DISPLAY | AUDIO

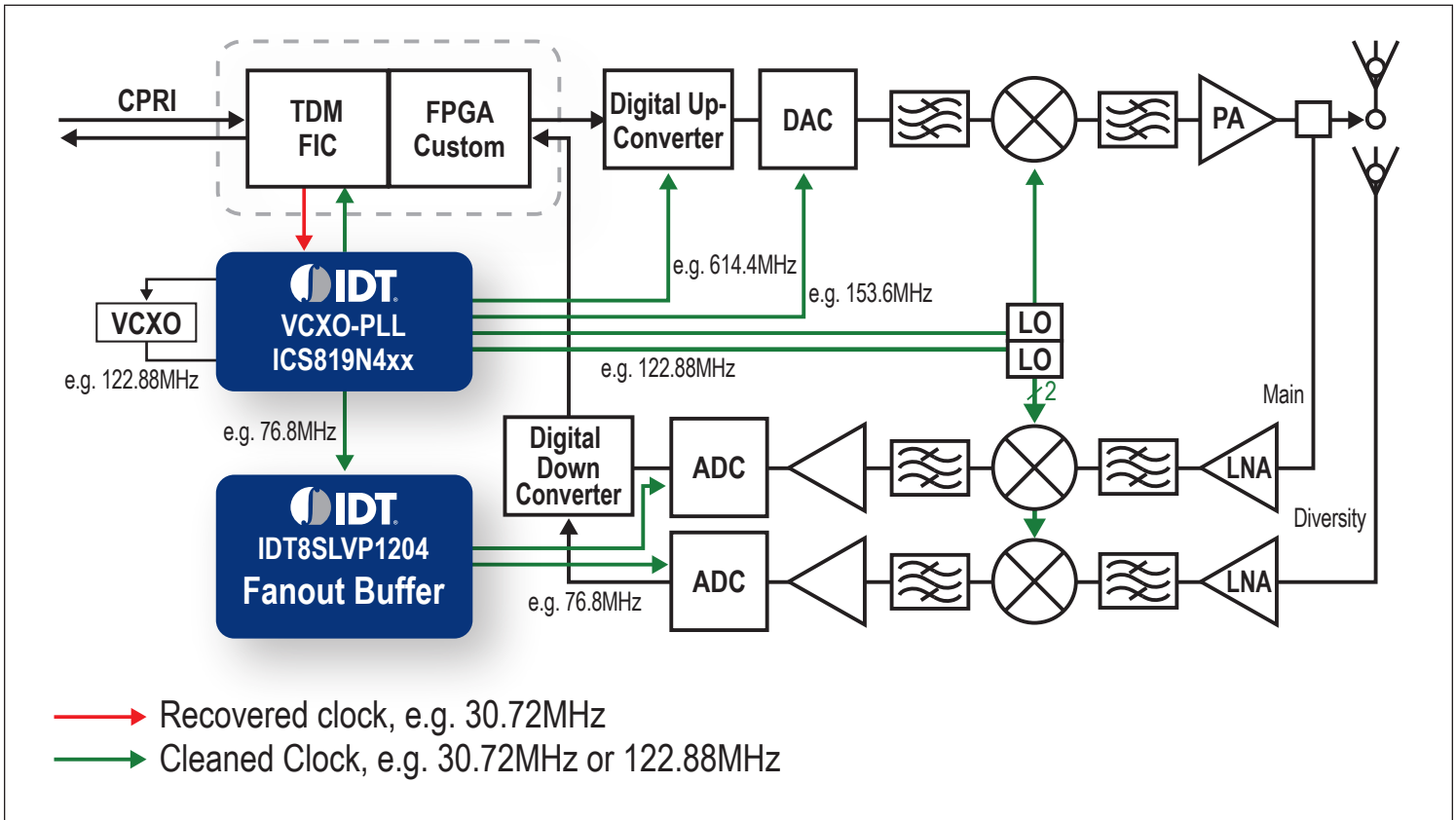

FEATURES AND BENEFITS

- Wide selection of differential output buffers
- Optimized for low additive phase noise
- Fast output rise fall/time (as low as 100ps)
- Low-skew outputs
- Accept LVDS, LVPECL, HSTL, CML inputs
- Support small packages (e.g. VFQN 3x3 to 5x5mm)
- Support integrated input termination networks for differential signals

APPLICATIONS

- Wireless infrastructure BTS
- Radio boards
- Driving ADC/DAC devices
- Wireline and Communications

Low Additive Phase Noise, Differential Clock Fanout Buffers for Wireless Infrastructure Radio Equipment

Device Overview

IDT's family of high-performance, low additive phase noise buffers is the ideal choice for use in designs where a clean frequency source is critical to a system's operation and performance. IDT fan-out buffers feature fully differential internal architecture, reducing jitter caused by inherent common-mode noise rejection and improving output skew. The differential circuitry is constant-current and therefore injects less noise into system power supplies than single-ended solutions, reducing EMI compliance concerns. These buffers are typically used for clock distribution on wireless infrastructure designs of radio boards where low phase noise is required. IDT's buffers are ideal for space-constraint designs by offering small footprint packaging as well as integrating the input termination network for differential signals.

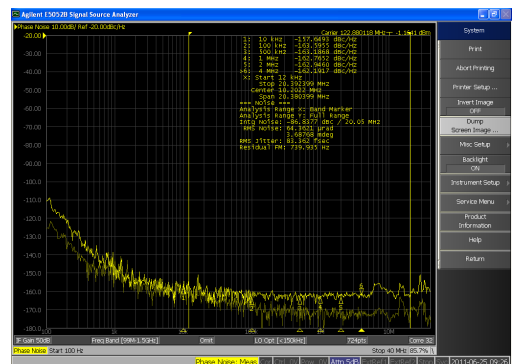

IDT8SLVP1204 Additive Phase Noise 83fs RMS (12kHz - 20MHz)



High-Performance, Low-Phase Noise Clocks Buffers

POWER MANAGEMENT | ANALOG & RF | INTERFACE & CONNECTIVITY | **CLOCKS & TIMING** | MEMORY & LOGIC | TOUCH & USER INTERFACE | VIDEO & DISPLAY | AUDIO

RF Frequency Buffer Components

Device	I/O	Function	Supply voltage	Max. Clock Freq. (MHz)	Package
853S0111	LVPECL	1:2 Fanout Buffer	2.5V, 3.3V	2500	8-TSSOP, 8-SOIC
8SLVP1102I	LVPECL	1:2 Fanout Buffer	2.5V, 3.3V	2000	16-VFQFN
8SLVP2102I	LVPECL	Dual 1:2 Fanout buffer	2.5V, 3.3V	2000	16-VFQFN
853S9252I	LVPECL	1:2 Fanout Buffer	2.5V, 3.3V	3000	16-VFQFN
853S54I-01	LVPECL	Dual 2:1, 1:2 mux, loopback	2.5V, 3.3V	2500	16-VFQFN
859S0212I	LVPECL/LVDS	1:2 Fanout Buffer (2:1 Mux)	2.5V, 3.3V	3000	16-TSSOP
859S0412I	LVPECL/LVDS	1:2 Fanout Buffer (4:1 Mux)	2.5V, 3.3V	3000	20-TSSOP
853S014I	LVPECL	1:5 Fanout Buffer	2.5V, 3.3V	2000	20-TSSOP
853S013I	LVPECL	Dual 1:3 Fanout Buffer	2.5V, 3.3V	2000	20-SOIC
8S89831I	LVPECL	1:4 Fanout Buffer	2.5V, 3.3V	2100	16-VFQFN
8SLVP1204I	LVPECL	1:4 Fanout Buffer	2.5V, 3.3V	2000	16-VFQFN
8S89832I	LVDS	1:4 Fanout Buffer	2.5V, 3.3V	2000	16-VFQFN
8S89833I	LVDS	1:4 Fanout Buffer	2.5V, 3.3V	2000	16-VFQFN
859S0424I	LVPECL/LVDS	1:4 Fanout Buffer (4:1 Mux)	2.5V, 3.3V	3000	24-TSSOP
8S58021I	LVPECL	1:4 Fanout Buffer	2.5V, 3.3V	2500	16-VFQFN
853S314I	LVPECL	1:4 Fanout Buffer	2.5V, 3.3V	2700	20-TSSOP, 20-SSOP
8SLVP2104I	LVPECL	Dual 1:4 Fanout Buffer	2.5V, 3.3V	2000	28-VFQFN
853S006I	LVPECL	1:6 Fanout Buffer	2.5V, 3.3V	2000	20-TSSOP
8S58035I	LVPECL	1:6 Fanout Buffer (2:1 Mux)	2.5V, 3.3V	3200	32-VFQFN
8SLVP2106I	LVPECL	Dual 1:6 Fanout Buffer	2.5V, 3.3V	2000	40-VFQFN
8SLVP1208I	LVPECL	1:8 Fanout Buffer	2.5V, 3.3V	2000	28-VFQFN
8SLVP2108I	LVPECL	Dual 1:8 Fanout Buffer	2.5V, 3.3V	2000	48-VFQFN
853S031I	LVPECL	1:9 Fanout Buffer	2.5V, 3.3V	1600	32-LQFP
853S6111I	LVPECL	1:10 Fanout Buffer	2.5V, 3.3V	2700	32-TQFP
853S111AI	LVPECL	1:10 Fanout Buffer	2.5V, 3.3V	2500	32-TQFP
853S111BI	LVPECL	1:10 Fanout Buffer	2.5V, 3.3V	2500	32-TQFP, 32-VQFN
853S12I	LVPECL	1:12 Fanout Buffer	2.5V, 3.3V	1500	32-VFQFN
8SLVP1212I	LVPECL	1:12 Fanout Buffer	2.5V, 3.3V	2000	40-VFQFN
853S024	LVPECL	1:24 Fanout Buffer	2.5V, 3.3V	1500	64-TQFP

RF Frequency Divider Components

Device	I/O	Function	Supply voltage	Max. Clock Freq. (MHz)	Package
853S1208I	LVPECL	÷1, ÷2 Divider, Dual 1:4 Fanout Buffer	2.5V, 3.3V	700	48-LQFP
853S1204I	LVPECL	÷1, ÷2 Divider and 1:4 Fanout Buffer	2.5V, 3.3V	700	24-TSSOP
MC100ES6039	LVPECL	÷2/÷4, ÷4/÷6 Divider	3.3V	1000	20-SOIC, 20-TSSOP
MC100ES6226	LVPECL	÷1, ÷2 Divider, Triple 1:3 Fanout Buffer	2.3V, 2.5V	3000	32-LQFP
8S73034I	LVPECL	÷1, ÷2, ÷8 Divider	2.5V, 3.3V	3200	16-SOIC, 16-TSSOP
8S89200I	LVDS	÷1, ÷2, ÷8 Divider with 1:4, 1:3 and 1:1 Fanout	2.5V	3000, 1500	32-VFQFN
8S89202I	LVPECL	÷1, ÷2, ÷8 Divider with 1:4, 1:3 and 1:1 Fanout	2.5V, 3.3V	3000, 1500	32-VFQFN
8S89874I	LVPECL	÷1, ÷2, ÷4, ÷8, ÷16 Divider with 1:2 Fanout Buffer	2.5V, 3.3V	2000	16-VFQFN
8S89875I	LVDS	÷1, ÷2, ÷4, ÷8, ÷16 Divider with 1:2 Fanout Buffer	2.5V	2500	16-VFQFN
8S89876I	LVDS	÷1, ÷2, ÷4, ÷8, ÷16 Divider with 1:2 Fanout Buffer	3.3V	2500	16-VFQFN
874328I-01	LVPECL/LVDS	÷1, ÷4 Divider and 1:20 Fanout Buffer	2.5V	650	64-TQFP

RF Frequency Multiplexer Components

Device	I/O	Function	Supply voltage	Max. Clock Freq. (MHz)	Package
853S01I	LVPECL	2:1 Mux	2.5V, 3.3V	2500	16-VFQFN, 16-TSSOP
MC100ES6254	LVPECL	2x2 Switch/Dual 1:3/Single 1:6 Fanout	2.5V, 3.3V	3000	32-LQFP
853S057I	LVPECL	4:1 Mux	2.5V, 3.3V	3000	20-TSSOP
853S058I	LVPECL	8:1 Mux	2.5V, 3.3V	2500	24-TSSOP
853S012I	LVPECL	12:1 Mux	2.5V, 3.3V	3200	32-VFQFN
853S202I	LVPECL	12:2 Mux/Switch	2.5V, 3.3V	3000	48-LQFP

Discover Why IDT is the Leader in Timing Solutions at www.IDT.com/go/clocks

DISCLAIMER Integrated Device Technology, Inc. (IDT) and its subsidiaries reserve the right to modify the products and/or specifications described herein at any time and at IDT's sole discretion. All information in this document, including descriptions of product features and performance, is subject to change without notice. Performance specifications and the operating parameters of the described products are determined in the independent state and are not guaranteed to perform the same way when installed in customer products. The information contained herein is provided without representation or warranty of any kind, whether express or implied, including, but not limited to, the suitability of IDT's products for any particular purpose, an implied warranty of merchantability, or non-infringement of the intellectual property rights of others. This document is presented only as a guide and does not convey any license under intellectual property rights of IDT or any third parties. IDT's products are not intended for use in life support systems or similar devices where the failure or malfunction of an IDT product can be reasonably expected to significantly affect the health or safety of users. Anyone using an IDT product in such a manner does so at their own risk, absent an express, written agreement by IDT.

Integrated Device Technology, IDT and the IDT logo are registered trademarks of IDT. Other trademarks and service marks used herein, including protected names, logos and designs, are the property of IDT or their respective third party owners. © Copyright 2012. All rights reserved.

PB_HPLPNCLOCKSBUFF_REVA0412