

阅读申明

- 1.本站收集的数据手册和产品资料都来自互联网，版权归原作者所有。如读者和版权方有任何异议请及时告之，我们将妥善解决。
- 2.本站提供的中文数据手册是英文数据手册的中文翻译，其目的是协助用户阅读，该译文无法自动跟随原稿更新，同时也可能存在翻译上的不当。建议读者以英文原稿为参考以便获得更精准的信息。
- 3.本站提供的产品资料，来自厂商的技术支持或者使用者的心得体会等，其内容可能存在描述上的差异，建议读者做出适当判断。
- 4.如需与我们联系，请发邮件到marketing@iczoom.com，主题请标有“数据手册”字样。

Read Statement

1. The datasheets and other product information on the site are all from network reference or other public materials, and the copyright belongs to the original author and original published source. If readers and copyright owners have any objections, please contact us and we will deal with it in a timely manner.
2. The Chinese datasheets provided on the website is a Chinese translation of the English datasheets. Its purpose is for reader's learning exchange only and do not involve commercial purposes. The translation cannot be automatically updated with the original manuscript, and there may also be improper translations. Readers are advised to use the English manuscript as a reference for more accurate information.
3. All product information provided on the website refer to solutions from manufacturers' technical support or users the contents may have differences in description, and readers are advised to take the original article as the standard.
4. If you have any questions, please contact us at marketing@iczoom.com and mark the subject with "Datasheets" .



FEATURES:

- Clock Distribution
- 10MHz to 133MHz operating frequency
- Distributes one clock input to one bank of five outputs
- Output Skew < 250ps
- No external RC network required
- Operates at 2.5V VDD
- Available in SOIC package
- Available in commercial and industrial temperature range

DESCRIPTION:

The IDT2305NZT is a high-speed clock buffer, designed to address high-speed clock distribution applications. IDT2305NZT accepts one reference input, and drives out five low skew clocks.

FUNCTIONAL BLOCK DIAGRAM

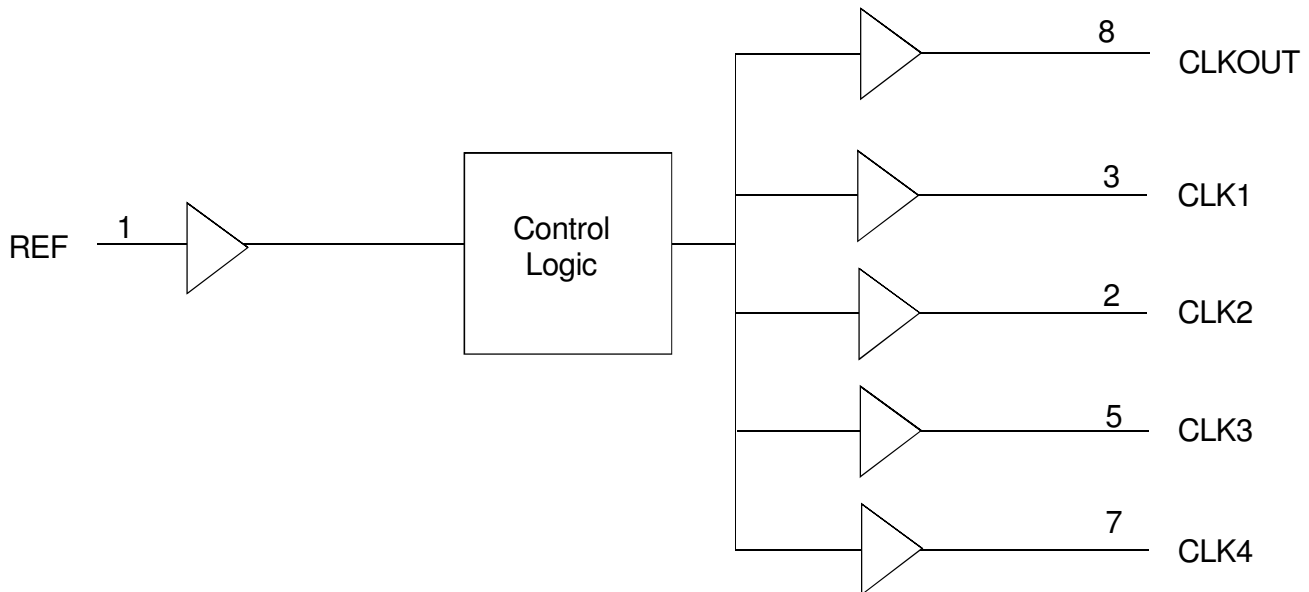

PIN CONFIGURATION

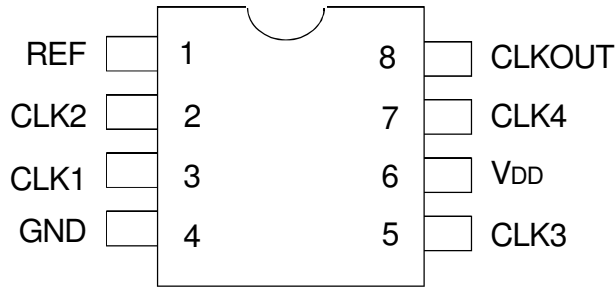

ABSOLUTE MAXIMUM RATINGS⁽¹⁾

Symbol	Rating	Max.	Unit
V _{DD}	Supply Voltage Range	-0.5 to +4.6	V
V _I ⁽²⁾	Input Voltage Range (REF)	-0.5 to +5.5	V
V _I	Input Voltage Range (except REF)	-0.5 to V _{DD} +0.5	V
I _{IK} (V _I < 0)	Input Clamp Current	-50	mA
I _O (V _O = 0 to V _{DD})	Continuous Output Current	±50	mA
V _{DD} or GND	Continuous Current	±100	mA
T _A = 55°C (in still air) ⁽³⁾	Maximum Power Dissipation	0.7	W
T _{STG}	Storage Temperature Range	-65 to +150	°C
Operating Temperature	Industrial Temperature Range	-40 to +85	°C

NOTES:

- Stresses greater than those listed under ABSOLUTE MAXIMUM RATINGS may cause permanent damage to the device. This is a stress rating only and functional operation of the device at these or any other conditions above those indicated in the operational sections of this specification is not implied. Exposure to absolute maximum rating conditions for extended periods may affect reliability.
- The input and output negative-voltage ratings may be exceeded if the input and output clamp-current ratings are observed.
- The maximum package power dissipation is calculated using a junction temperature of 150°C and a board trace length of 750 mils.

APPLICATIONS:

- SDRAM
- Telecom
- Datacom
- PC Motherboards/Workstations
- Critical Path Delay Designs

PIN DESCRIPTION

Pin Name	Pin Number	Type	Functional Description
REF ⁽¹⁾	1	IN	Input reference clock, 3.3V tolerant input
CLK2 ⁽²⁾	2	OUT	Output clock
CLK1 ⁽²⁾	3	OUT	Output clock
GND	4	GND	Ground
CLK3 ⁽²⁾	5	OUT	Output clock
V _{DD}	6	PWR	2.5V Supply
CLK4 ⁽²⁾	7	OUT	Output clock
CLKOUT ⁽²⁾	8	OUT	Output clock

NOTES:

- Weak pull down.
- Weak pull down on all outputs.

OPERATING CONDITIONS

Symbol	Parameter	Min.	Max.	Unit
VDD	Supply Voltage	2.3	2.7	V
TA	Operating Temperature (Ambient Temperature)	-40	+85	°C
CL	Load Capacitance 10MHz - 133MHz	—	15	pF
CIN	Input Capacitance	—	7	pF

DC ELECTRICAL CHARACTERISTICS

Symbol	Parameter	Conditions	Min.	Max.	Unit
VIL	Input LOW Voltage Level		—	0.7	V
VIH	Input HIGH Voltage Level		1.7	—	V
IIL	Input LOW Current	VIN = 0V	—	50	μA
IIH	Input HIGH Current	VIN = VDD	—	100	μA
VOL	Output LOW Voltage	Standard Drive, IOL = 8mA	—	0.3	V
VOH	Output HIGH Voltage	Standard Drive, IOH = -8mA	2	—	V
IDD_PD	Power Down Current	REF = 0MHz	—	12	μA
IDD	Supply Current	Unloaded Outputs at 66.66MHz	—	32	mA

SWITCHING CHARACTERISTICS^(1,2)

Symbol	Parameter	Conditions	Min.	Typ.	Max.	Unit
t1	Output Frequency	15pF Load	10	—	133	MHz
	Duty Cycle = t2 ÷ t1	Measured at VDD/2, FOUT = 66.66MHz	40	50	60	%
t3	Rise Time	Measured between 0.7V and 1.7V	—	—	2.5	ns
t4	Fall Time	Measured between 0.7V and 1.7V	—	—	2.5	ns
t5	Output to Output Skew	All outputs equally loaded	—	—	250	ps
t6	Delay, REF Rising Edge to CLKOUT Rising Edge	Measured at VDD/2	—	0	8.7	ns
t7	Device-to-Device Skew	Measured at VDD/2 on the CLKOUT pins of devices	—	0	700	ps

NOTES:

1. REF Input has a threshold voltage of VDD/2.
2. All parameters specified with loaded outputs.

TEST CIRCUIT

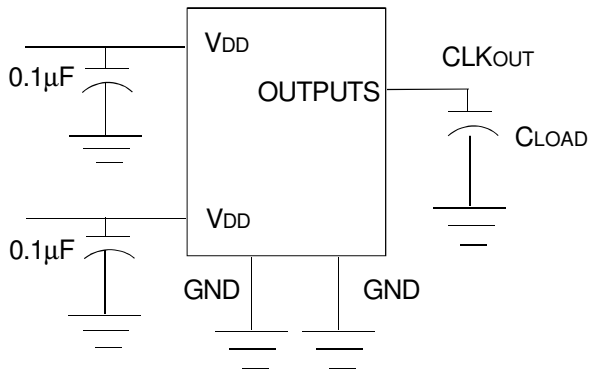

Test Circuit for All Parameters

SWITCHING WAVEFORMS

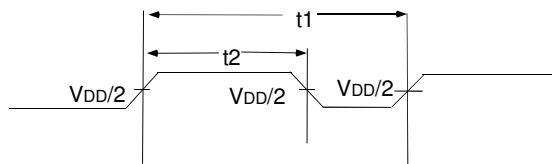

Duty Cycle Timing

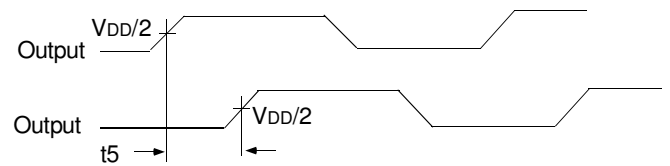

Output to Output Skew

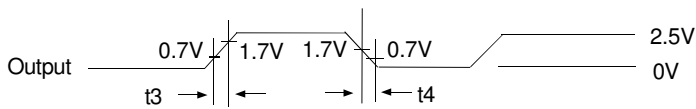

All Outputs Rise/Fall Time

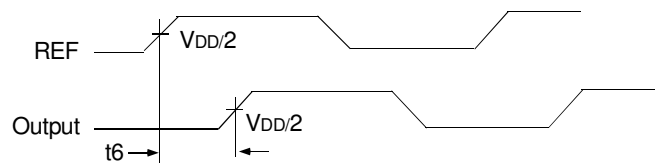

Input to Output Propagation Delay

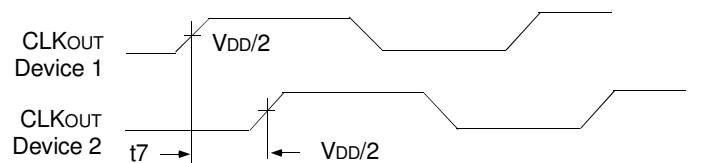

Device to Device Skew

Package Outline and Package Dimensions (8-pin SOIC, 150 Mil. Body)

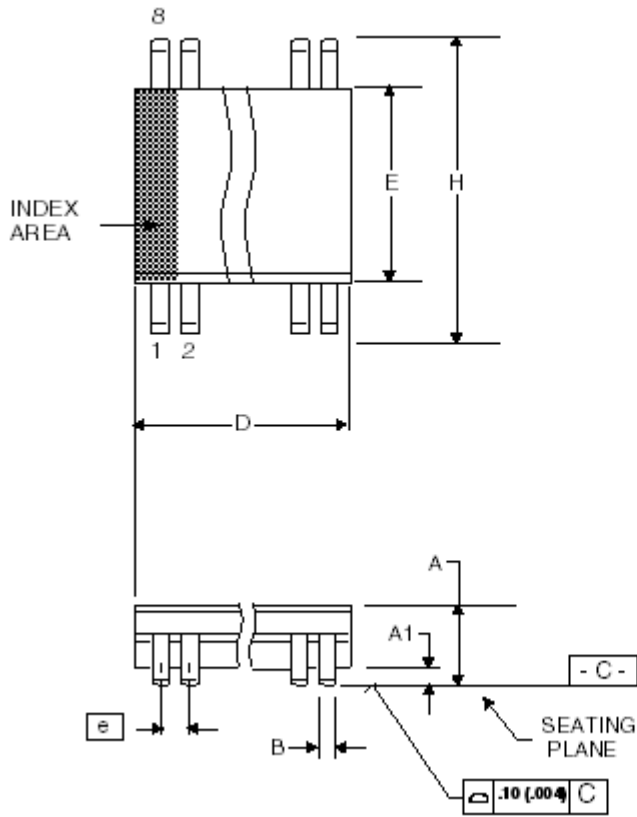

Symbol	Millimeters		Inches	
	Min	Max	Min	Max
A	1.35	1.75	0.0532	0.0688
A1	0.1	0.25	0.004	0.0098
B	0.33	0.51	0.013	0.02
C	0.19	0.25	0.0075	0.0098
D	4.8	5	0.189	0.1968
E	3.8	4	0.1497	0.1574
e	1.27 BASIC		0.050 BASIC	
H	5.8	6.2	0.2284	0.244
h	0.25	0.5	0.01	0.02
L	0.4	1.27	0.016	0.05
a	0°	8°	0°	8°

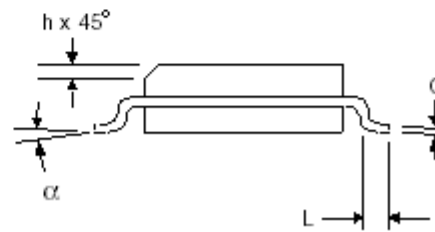

Ordering Information

Part / Order Number	Shipping Packaging	Package	Temperature
2305NZT-1DCG	Tubes	8-pin SOIC	0 to +70° C
2305NZT-1DCG8	Tape and Reel	8-pin SOIC	0 to +70° C
2305NZT-1DCGI	Tubes	8-pin SOIC	-40 to +85° C
2305NZT-1DCGI8	Tape and Reel	8-pin SOIC	-40 to +85° C

"G" after the two-letter package code denotes Pb free configuration, RoHS complaint.



CORPORATE HEADQUARTERS
6024 Silver Creek Valley Road
San Jose, CA 95138

for SALES:
800-345-7015 or 408-284-8200
fax: 408-284-2775
www.idt.com

for Tech Support:
www.idt.com/go/clockhelp