

阅读申明

- 1.本站收集的数据手册和产品资料都来自互联网，版权归原作者所有。如读者和版权方有任何异议请及时告之，我们将妥善解决。
- 2.本站提供的中文数据手册是英文数据手册的中文翻译，其目的是协助用户阅读，该译文无法自动跟随原稿更新，同时也可能存在翻译上的不当。建议读者以英文原稿为参考以便获得更精准的信息。
- 3.本站提供的产品资料，来自厂商的技术支持或者使用者的心得体会等，其内容可能存在描述上的差异，建议读者做出适当判断。
- 4.如需与我们联系，请发邮件到marketing@iczoom.com，主题请标有“数据手册”字样。

Read Statement

1. The datasheets and other product information on the site are all from network reference or other public materials, and the copyright belongs to the original author and original published source. If readers and copyright owners have any objections, please contact us and we will deal with it in a timely manner.
2. The Chinese datasheets provided on the website is a Chinese translation of the English datasheets. Its purpose is for reader's learning exchange only and do not involve commercial purposes. The translation cannot be automatically updated with the original manuscript, and there may also be improper translations. Readers are advised to use the English manuscript as a reference for more accurate information.
3. All product information provided on the website refer to solutions from manufacturers' technical support or users the contents may have differences in description, and readers are advised to take the original article as the standard.
4. If you have any questions, please contact us at marketing@iczoom.com and mark the subject with "Datasheets" .

The MPC94551 is a CMOS 1:4 fanout buffer. The MPC94551 is ideal for applications requiring lower voltage.

Features

- 1:4 CMOS fanout buffer
- 300 ps output to output skew
- I/O frequency up to 160 MHz operation
- Non-inverting output clock
- 3.3 V supply voltage
- Output Enable mode tri-states outputs
- -40°C to 85°C industrial temperature range
- 8-lead SOIC package, Pb-free
- **For drop in replacement use 551MI**

MPC94551

**1:4 LVC MOS
CLOCK BUFFER**



**EF SUFFIX
8-LEAD SOIC PACKAGE
Pb-FREE PACKAGE
CASE 751-06**

ORDERING INFORMATION	
Device	Package
MPC94551EF	SO-8 (Pb-FREE)
MPC94551EFR2	SO-8 (Pb-FREE)

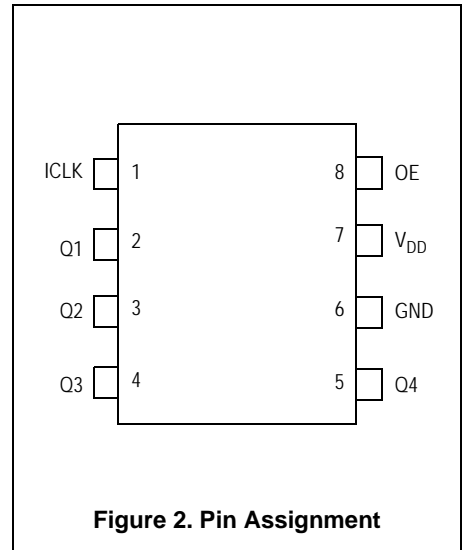
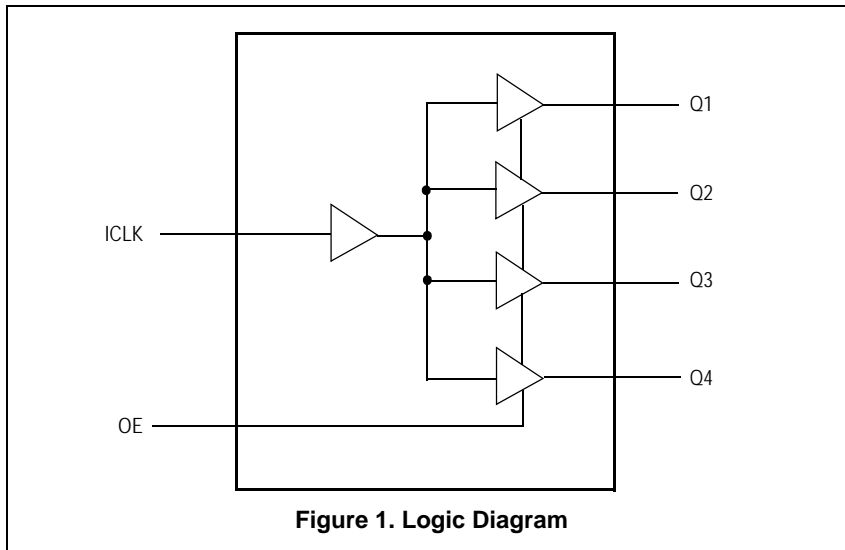

Table 1. Pin Description

Pin Number	Pin Name	Pin Type	Pin Description
1	ICLK	Input	Clock input, internal pull-up resistor
2	Q1	Output	Clock output ⁽¹⁾
3	Q2	Output	Clock output ⁽¹⁾
4	Q3	Output	Clock output ⁽¹⁾
5	Q4	Output	Clock output ⁽¹⁾
6	GND	Power	Connect to ground ⁽²⁾
7	V _{DD}	Power	Connect to 3.3 V ⁽²⁾
8	OE	Input	Output enable, tri-states outputs when low, internal pull-up resistor

1. A 33 Ω series terminating resistor may be used on each clock output if the trace is longer than 1 inch.
2. A decoupling capacitor of 0.01 μF should be connected between V_{DD} on pin 7 and GND on pin 6, as close to the device as possible.

Table 2. Absolute Maximum Ratings⁽¹⁾

Parameter	Rating	Unit
Power Supply Voltage, V _{DD}	3.9	V
All Inputs and Outputs	-0.5 to V _{DD} +0.5	V
Ambient Operating Temperature	-40 to +85	°C
Storage Temperature	-65 to +150	°C
Junction Temperature	175	°C
Soldering Temperature	260	°C

PACKAGE DIMENSIONS

1. Stresses above the ratings listed below can cause permanent damage to the device. These ratings are stress ratings only. Functional operation of the device at these or any other conditions above those indicated in the operational sections of the specifications is not implied.

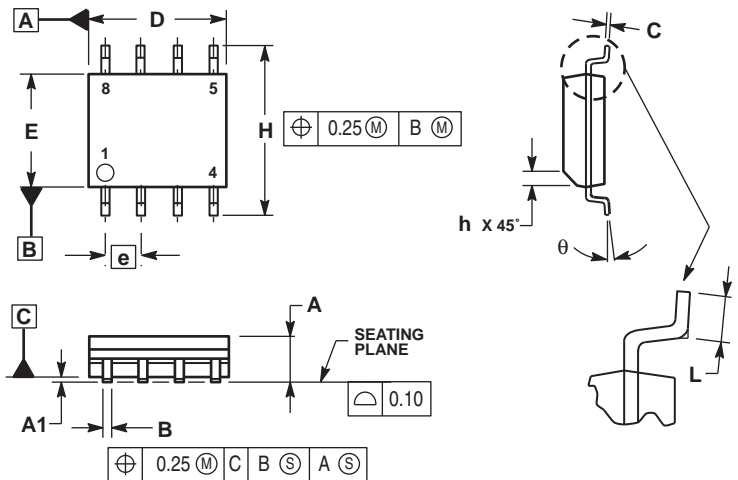

- NOTES:
1. DIMENSIONING AND TOLERANCING PER ASME Y14.5M, 1994.
 2. DIMENSIONS ARE IN MILLIMETER.
 3. DIMENSION D AND E DO NOT INCLUDE MOLD PROTRUSION.
 4. MAXIMUM MOLD PROTRUSION 0.15 PER SIDE.
 5. DIMENSION B DOES NOT INCLUDE DAMBAR PROTRUSION. ALLOWABLE DAMBAR PROTRUSION SHALL BE 0.127 TOTAL IN EXCESS OF THE B DIMENSION AT MAXIMUM MATERIAL CONDITION.

DIM	MILLIMETERS	
	MIN	MAX
A	1.35	1.75
A1	0.10	0.25
B	0.35	0.49
C	0.19	0.25
D	4.80	5.00
E	3.80	4.00
e	1.27 BSC	
H	5.80	6.20
h	0.25	0.50
L	0.40	1.25
θ	0°	7°

Input Capacitance	C _{IN}	OE	D/EF SUFFIX	5	pF
	C _{IN}	ICLK	SOIC PACKAGE	1	pF
Short Circuit Current	I _{OS}		CASE 751-06	±50	mA

1. Nominal switching threshold is V_{DD}/2.

Table 4. AC Characteristics ($V_{DD} = 3.3\text{ V} \pm 5\%$; Ambient Temperature = -40°C to 85°C)

Parameter	Symbol	Condition	Min	Typ	Max	Unit
Input Frequency			0		160	MHz
Output Frequency ⁽¹⁾		15 pF load			160	MHz
Output Clock Rise Time	t_{OR}	0.8 V to 2.0 V			1.5	ns
Output Clock Fall Time	t_{OF}	2.0 V to 0.8 V			1.5	ns
Propagation Delay ⁽²⁾		135 MHz	1.5	4	5	ns
Output to Output Skew ⁽³⁾		Rising edges at $V_{DD}/2$			300	ps

1. Measured with an external series resistor of 33Ω positioned close to each output pin
2. Measured with rail to rail input clock
3. Measured between any 2 outputs with equal loading

Revision History Sheet

Rev	Table	Page	Description of Change	Date
4		1	NRND – Not Recommend for New Designs	12/21/12
4		1	Removed NRND	5/5/15
4		1	Product Discontinuation Notice - Last time buy expires September 7, 2016. PDN N-16-02	3/15/16

We've Got Your Timing Solution



6024 Silver Creek Valley Road
San Jose, California 95138

Sales
800-345-7015 (inside USA)
+408-284-8200 (outside USA)
Fax: 408-284-2775
www.IDT.com/go/contactIDT

Technical Support
clocks@idt.com
+480-763-2056

DISCLAIMER Integrated Device Technology, Inc. (IDT) and its subsidiaries reserve the right to modify the products and/or specifications described herein at any time and at IDT's sole discretion. All information in this document, including descriptions of product features and performance, is subject to change without notice. Performance specifications and the operating parameters of the described products are determined in the independent state and are not guaranteed to perform the same way when installed in customer products. The information contained herein is provided without representation or warranty of any kind, whether express or implied, including, but not limited to, the suitability of IDT's products for any particular purpose, an implied warranty of merchantability, or non-infringement of the intellectual property rights of others. This document is presented only as a guide and does not convey any license under intellectual property rights of IDT or any third parties.

IDT's products are not intended for use in applications involving extreme environmental conditions or in life support systems or similar devices where the failure or malfunction of an IDT product can be reasonably expected to significantly affect the health or safety of users. Anyone using an IDT product in such a manner does so at their own risk, absent an express, written agreement by IDT.

Integrated Device Technology, IDT and the IDT logo are registered trademarks of IDT. Other trademarks and service marks used herein, including protected names, logos and designs, are the property of IDT or their respective third party owners.

©2016 Integrated Device Technology, Inc. All rights reserved.