

阅读申明

- 1.本站收集的数据手册和产品资料都来自互联网，版权归原作者所有。如读者和版权方有任何异议请及时告之，我们将妥善解决。
- 2.本站提供的中文数据手册是英文数据手册的中文翻译，其目的是协助用户阅读，该译文无法自动跟随原稿更新，同时也可能存在翻译上的不当。建议读者以英文原稿为参考以便获得更精准的信息。
- 3.本站提供的产品资料，来自厂商的技术支持或者使用者的心得体会等，其内容可能存在描述上的差异，建议读者做出适当判断。
- 4.如需与我们联系，请发邮件到marketing@iczoom.com，主题请标有“数据手册”字样。

Read Statement

1. The datasheets and other product information on the site are all from network reference or other public materials, and the copyright belongs to the original author and original published source. If readers and copyright owners have any objections, please contact us and we will deal with it in a timely manner.
2. The Chinese datasheets provided on the website is a Chinese translation of the English datasheets. Its purpose is for reader's learning exchange only and do not involve commercial purposes. The translation cannot be automatically updated with the original manuscript, and there may also be improper translations. Readers are advised to use the English manuscript as a reference for more accurate information.
3. All product information provided on the website refer to solutions from manufacturers' technical support or users the contents may have differences in description, and readers are advised to take the original article as the standard.
4. If you have any questions, please contact us at marketing@iczoom.com and mark the subject with "Datasheets" .

General Description

The 5T93GL02 2.5V differential clock buffer is a user-selectable differential input to two LVDS outputs. The fanout from a differential input to two LVDS outputs reduces loading on the preceding driver and provides an efficient clock distribution network. The 5T93GL02 can act as a translator from a differential HSTL, eHSTL, LVEPECL (2.5V), LVPECL (3.3V), CML, or LVDS input to LVDS outputs. A single-ended 3.3V / 2.5V LVTTTL input can also be used to translate to LVDS outputs. The redundant input capability allows for a glitchless change-over from a primary clock source to a secondary clock source up to 450MHz. Selectable inputs are controlled by SEL. During the switchover, the output will disable low for up to three clock cycles of the previously-selected input clock. The outputs will remain low for up to three clock cycles of the newly-selected clock, after which the outputs will start from the newly-selected input. A FSEL pin has been implemented to control the switchover in cases where a clock source is absent or is driven to DC levels below the minimum specifications.

The 5T93GL02 outputs can be asynchronously enabled/disabled. When disabled, the outputs will drive to the value selected by the GL pin. Multiple power and grounds reduce noise.

Applications

- Clock distribution

Features

- Guaranteed low skew: <50ps (maximum)
- Very low duty cycle distortion: <100ps (maximum)
- High speed propagation delay: <2.2ns (maximum)
- Up to 450MHz operation
- Selectable inputs
- Hot insertable and over-voltage tolerant inputs
- 3.3V/2.5V LVTTTL, HSTL, eHSTL, LVEPECL (2.5V), LVPECL (3.3V), CML or LVDS input interface
- Selectable differential inputs to two LVDS outputs
- Power-down mode
- At power-up, FSEL should be LOW
- 2.5V V_{DD}
- -40°C to 85°C ambient operating temperature
- Available in TSSOP package
- Recommends IDT5T9302 if glitchless input selection is not required
- **Not Recommended for New Designs**
- **For functional replacement use 8SLVP1102**

Pin Assignment

GND	1	20	A2
\overline{PD}	2	19	$\overline{A2}$
FSEL	3	18	GND
V_{DD}	4	17	V_{DD}
$\overline{Q1}$	5	16	$\overline{Q2}$
Q1	6	15	Q2
V_{DD}	7	14	V_{DD}
SEL	8	13	GL
\overline{G}	9	12	$\overline{A1}$
GND	10	11	A1

20-Lead TSSOP
4.4mm x 6.5mm x 0.925mm package body
G Package
Top View

Block Diagram

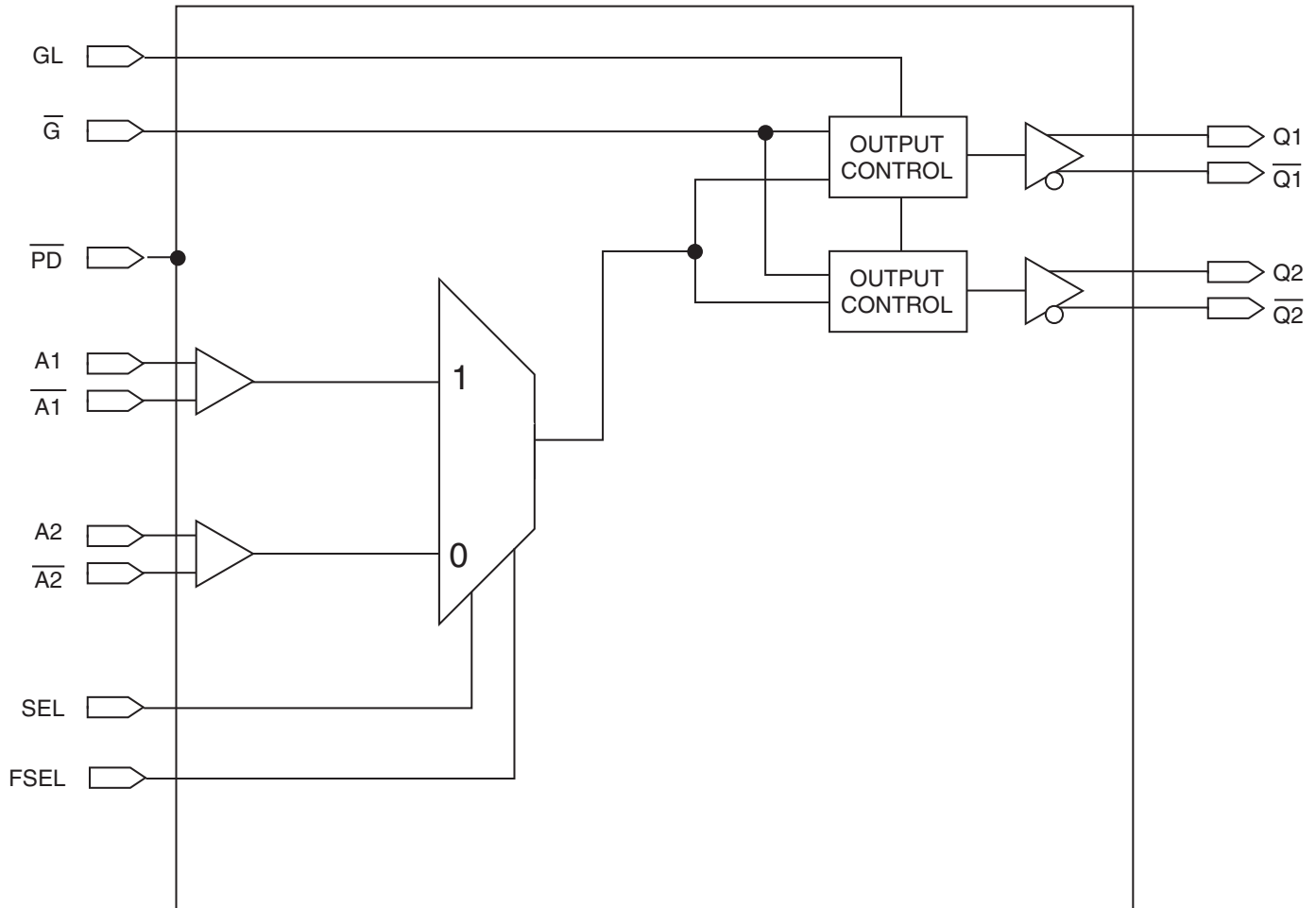

Table 1. Pin Descriptions

Name	Type		Description
A[1:2]	Input	Adjustable ^(1, 4)	Clock input. A[1:2] is the "true" side of the differential clock input.
$\overline{A[1:2]}$	Input	Adjustable ^(1, 4)	Complementary clock inputs. $\overline{A[1:2]}$ is the complementary side of A[1:2]. For LVTTTL single-ended operation, $\overline{A[1:2]}$ should be set to the desired toggle voltage for A[1:2]: 3.3V LVTTTL VREF = 1650mV 2.5V LVTTTL VREF = 1250mV
\overline{G}	Input	LVTTTL	Gate control for differential outputs Q1 and $\overline{Q1}$ through Q2 and $\overline{Q2}$. When \overline{G} is LOW, the differential outputs are active. When \overline{G} is HIGH, the differential outputs are asynchronously driven to the level designated by GL ⁽²⁾ .
GL	Input	LVTTTL	Specifies output disable level. If HIGH, "true" outputs disable HIGH and "complementary" outputs disable LOW. If LOW, "true" outputs disable LOW and "complementary" outputs disable HIGH.
Q[1:2]	Output	LVDS	Clock outputs.
$\overline{Q[1:2]}$	Output	LVDS	Complementary clock outputs.
SEL	Input	LVTTTL	Reference clock select. When LOW, selects A2 and $\overline{A2}$. When HIGH, selects A1 and $\overline{A1}$.
\overline{PD}	Input	LVTTTL	Power-down control. Shuts off entire chip. If LOW, the device goes into low power mode. Inputs and outputs are disabled. Both "true" and "complementary" outputs will pull to VDD. Set HIGH for normal operation. ⁽³⁾
FSEL	Input	LVTTTL	At a rising edge, FSEL forces select to the input designated by SEL. Set LOW for normal operation. At power-up, FSEL should be LOW.
V _{DD}		Power	Power supply for the device core and inputs.
GND		Power	Ground.

NOTES:

- Inputs are capable of translating the following interface standards:
Single-ended 3.3V and 2.5V LVTTTL levels
Differential HSTL and eHSTL levels
Differential LVEPECL (2.5V) and LVPECL (3.3V) levels
Differential LVDS levels
Differential CML levels
- Because the gate controls are asynchronous, runt pulses are possible. It is the user's responsibility to either time the gate control signals to minimize the possibility of runt pulses or be able to tolerate them in down stream circuitry.
- It is recommended that the outputs be disabled before entering power-down mode. It is also recommended that the outputs remain disabled until the device completes power-up after asserting \overline{PD} .
- The user must take precautions with any differential input interface standard being used in order to prevent instability when there is no input signal.

Table 2. Pin Characteristics (T_A = +25°C, F = 1.0MHz)

Symbol	Parameter	Test Conditions	Minimum	Typical	Maximum	Units
C _{IN}	Input Capacitance				3	pF

NOTE: This parameter is measured at characterization but not tested.

Function Tables

Table 3A. Gate Control Output Table

Control Output		Outputs	
GL	\overline{G}	Q[1:2]	$\overline{Q[1:2]}$
0	0	Toggling	Toggling
0	1	LOW	HIGH
1	0	Toggling	Toggling
1	1	HIGH	LOW

Table 3B. Input Selection Table

Selection SEL pin	Inputs
0	A2/ $\overline{A2}$
1	A1/ $\overline{A1}$

Absolute Maximum Ratings

NOTE: Stresses beyond those listed under *Absolute Maximum Ratings* may cause permanent damage to the device. These ratings are stress specifications only. Functional operation of product at these conditions or any conditions beyond those listed in the *DC Characteristics* or *AC Characteristics* is not implied. Exposure to absolute maximum rating conditions for extended periods may affect product reliability.

Item	Rating
Power Supply Voltage, V_{DD}	-0.5V to +3.6V
Input Voltage, V_I	-0.5V to +3.6V
Output Voltage, V_O Not to exceed 3.6V	-0.5 to $V_{DD} + 0.5V$
Storage Temperature, T_{STG}	-65°C to 150°C
Junction Temperature, T_J	150°C

Recommended Operating Range

Symbol	Description	Minimum	Typical	Maximum	Units
T_A	Ambient Operating Temperature	-40	+25	+85	°C
V_{DD}	Internal Power Supply Voltage	2.3	2.5	2.7	V

DC Electrical Characteristics

Table 4A. LVDS Power Supply DC Characteristics⁽¹⁾, T_A = -40°C to 85°C

Symbol	Parameter	Test Conditions	Minimum	Typical	Maximum	Units
I _{DDQ}	Quiescent V _{DD} Power Supply Current	V _{DD} = Max., All Input Clocks = LOW ⁽²⁾ ; Outputs enabled			240	mA
I _{TOT}	Total Power V _{DD} Supply Current	V _{DD} = 2.7V; F _{REFERENCE} Clock = 450MHz			250	mA
I _{PD}	Total Power Down Supply Current	\overline{PD} = LOW			5	mA

NOTE 1: These power consumption characteristics are for all the valid input interfaces and cover the worst case conditions.

NOTE 2: The true input is held LOW and the complementary input is held HIGH.

Table 4B. LVTTTL DC Characteristics⁽¹⁾, T_A = -40°C to 85°C

Symbol	Parameter	Test Conditions	Minimum	Typical ⁽²⁾	Maximum	Units
I _{IH}	Input High Current	V _{DD} = 2.7V			±5	μA
I _{IL}	Input Low Current	V _{DD} = 2.7V			±5	μA
V _{IK}	Clamp Diode Voltage	V _{DD} = 2.3V, I _{IN} = -18mA		-0.7	-1.2	V
V _{IN}	DC Input Voltage		-0.3		3.6	V
V _{IH}	DC Input High Voltage		1.7			V
V _{IL}	DC Input Low Voltage				0.7	V
V _{THI}	DC Input Threshold Crossing Voltage			V _{DD} /2		V
V _{REF}	Single-Ended Reference Voltage ⁽³⁾	3.3V LVTTTL		1.65		V
		2.5V LVTTTL		1.25		V

NOTE 1: See *Recommended Operating Range* table.

NOTE 2: Typical values are at V_{DD} = 2.5V, +25°C ambient.

NOTE 3: For A[1:2] single-ended operation, \overline{A} [1:2] is tied to a DC reference voltage.

Table 4C. Differential DC Characteristics⁽¹⁾, T_A = -40°C to 85°C

Symbol	Parameter	Test Conditions	Minimum	Typical ⁽⁴⁾	Maximum	Units
I _{IH}	Input High Current	V _{DD} = 2.7V			±5	μA
I _{IL}	Input Low Current	V _{DD} = 2.7V			±5	μA
V _{IK}	Clamp Diode Voltage	V _{DD} = 2.3V, I _{IN} = -18mA		-0.7	-1.2	V
V _{IN}	DC Input Voltage		-0.3		3.6	V
V _{DIF}	DC Differential Voltage ⁽²⁾		0.1			V
V _{CM}	DC Common Mode Input Voltage ⁽³⁾		0.05		V _{DD}	V

NOTE 1: See *Recommended Operating Range* table.

NOTE 2: V_{DIF} specifies the minimum input differential voltage (V_{TR} - V_{CP}) required for switching where V_{TR} is the "true" input level and V_{CP} is the "complement" input level. The DC differential voltage must be maintained to guarantee retaining the existing HIGH or LOW input. The AC differential voltage must be achieved to guarantee switching to a new state.

NOTE 3: V_{CM} specifies the maximum allowable range of (V_{TR} + V_{CP}) / 2.

NOTE 4: Typical values are at V_{DD} = 2.5V, +25°C ambient.

Table 4D. LVDS DC Characteristics⁽¹⁾, $T_A = -40^\circ\text{C}$ to 85°C

Symbol	Parameter	Test Conditions	Minimum	Typical ⁽²⁾	Maximum	Units
$V_{OT(+)}$	Differential Output Voltage for the True Binary State		247		454	mV
$V_{OT(-)}$	Differential Output Voltage for the False Binary State		247		454	mV
ΔV_{OT}	Change in V_{OT} Between Complementary Output States				50	mV
V_{OS}	Output Common Mode Voltage (Offset Voltage)		1.125	1.2	1.375	V
ΔV_{OS}	Change in V_{OS} Between Complementary Output States				50	mV
I_{OS}	Outputs Short Circuit Current	V_{OUT+} and $V_{OUT-} = 0V$		12	24	mA
I_{OSD}	Differential Outputs Short Circuit Current	$V_{OUT+} = V_{OUT-}$		6	12	mA

NOTE 1: See *Recommended Operating Range* table.

NOTE 2: Typical values are at $V_{DD} = 2.5V$, $+25^\circ\text{C}$ ambient.

AC Electrical Characteristics

Table 5A. HSTL Differential Input AC Characteristics, $T_A = -40^\circ\text{C}$ to 85°C

Symbol	Parameter	Value	Units
V_{DIF}	Input Signal Swing ⁽¹⁾	1	V
V_X	Differential Input Signal Crossing Point ⁽²⁾	750	mV
D_H	Duty Cycle	50	%
V_{THI}	Input Timing Measurement Reference Level ⁽³⁾	Crossing Point	V
t_R / t_F	Input Signal Edge Rate ⁽⁴⁾	2	V/ns

NOTE 1. The 1V peak-to-peak input pulse level is specified to allow consistent, repeatable results in an automatic test equipment (ATE) environment. This device meets the V_{DIF} (AC) specification under actual use conditions.

NOTE 2. A 750mV crossing point level is specified to allow consistent, repeatable results in an automatic test equipment (ATE) environment. This device meets the V_X specification under actual use conditions.

NOTE 3. In all cases, input waveform timing is marked at the differential cross-point of the input signals.

NOTE 4. The input signal edge rate of 2V/ns or greater is to be maintained in the 20% to 80% range of the input waveform.

Table 5B. eHSTL AC Differential Input Characteristics, $T_A = -40^\circ\text{C}$ to 85°C

Symbol	Parameter	Value	Units
V_{DIF}	Input Signal Swing ⁽¹⁾	1	V
V_X	Differential Input Signal Crossing Point ⁽²⁾	900	mV
D_H	Duty Cycle	50	%
V_{THI}	Input Timing Measurement Reference Level ⁽³⁾	Crossing Point	V
t_R / t_F	Input Signal Edge Rate ⁽⁴⁾	2	V/ns

NOTE 1. The 1V peak-to-peak input pulse level is specified to allow consistent, repeatable results in an automatic test equipment (ATE) environment. This device meets the V_{DIF} (AC) specification under actual use conditions.

NOTE 2. A 900mV crossing point level is specified to allow consistent, repeatable results in an automatic test equipment (ATE) environment. This device meets the V_X specification under actual use conditions.

NOTE 3. In all cases, input waveform timing is marked at the differential cross-point of the input signals.

NOTE 4. The input signal edge rate of 2V/ns or greater is to be maintained in the 20% to 80% range of the input waveform.

Table 5C. LVEPECL (2.5V) and LVPECL (3.3V) Differential Input AC Characteristics, $T_A = -40^\circ\text{C}$ to 85°C

Symbol	Parameter	Maximum	Units
V_{DIF}	Input Signal Swing ⁽¹⁾	732	mV
V_X	Differential Input Cross Point Voltage ⁽²⁾	LVEPECL	1082
		LVPECL	1880
D_H	Duty Cycle	50	%
V_{THI}	Input Timing Measurement Reference Level ⁽³⁾	Crossing Point	V
t_R / t_F	Input Signal Edge Rate ⁽⁴⁾	2	V/ns

NOTE 1. The 732mV peak-to-peak input pulse level is specified to allow consistent, repeatable results in an automatic test equipment (ATE) environment. This device meets the V_{DIF} (AC) specification under actual use conditions.

NOTE 2. A 1082mV LVEPECL (2.5V) and 1880mV LVPECL (3.3V) crossing point level is specified to allow consistent, repeatable results in an automatic test equipment (ATE) environment. This device meets the V_X specification under actual use conditions.

NOTE 3. In all cases, input waveform timing is marked at the differential cross-point of the input signals.

NOTE 4. The input signal edge rate of 2V/ns or greater is to be maintained in the 20% to 80% range of the input waveform.

Table 5D. LVDS Differential Input AC Characteristics, $T_A = -40^\circ\text{C}$ to 85°C

Symbol	Parameter	Maximum	Units
V_{DIF}	Input Signal Swing ⁽¹⁾	400	mV
V_X	Differential Input Cross Point Voltage ⁽²⁾	1.2	V
D_H	Duty Cycle	50	%
V_{THI}	Input Timing Measurement Reference Level ⁽³⁾	Crossing Point	V
t_R / t_F	Input Signal Edge Rate ⁽⁴⁾	2	V/ns

NOTE 1. The 400mV peak-to-peak input pulse level is specified to allow consistent, repeatable results in an automatic test equipment (ATE) environment. This device meets the V_{DIF} (AC) specification under actual use conditions.

NOTE 2. A 1.2V crossing point level is specified to allow consistent, repeatable results in an automatic test equipment (ATE) environment. This device meets the V_X specification under actual use conditions.

NOTE 3. In all cases, input waveform timing is marked at the differential cross-point of the input signals.

NOTE 4. The input signal edge rate of 2V/ns or greater is to be maintained in the 20% to 80% range of the input waveform.

Table 5E. AC Differential Input Characteristics⁽¹⁾, $T_A = -40^{\circ}\text{C}$ to 85°C

Symbol	Parameter	Minimum	Typical	Maximum	Units
V_{DIF}	AC Differential Voltage ⁽²⁾	0.1		3.6	V
V_X	Differential Input Cross Point Voltage	0.05		V_{DD}	V
V_{CM}	Common Mode Input Voltage Range ⁽³⁾	0.05		V_{DD}	V
V_{IN}	Input Voltage	-0.3		3.6	V

NOTE 1. The output will not change state until the inputs have crossed and the minimum differential voltage range defined by V_{DIF} has been met or exceeded.

NOTE 2. V_{DIF} specifies the minimum input voltage ($V_{TR} - V_{CP}$) required for switching where V_{TR} is the “true” input level and V_{CP} is the “complement” input level. The AC differential voltage must be achieved to guarantee switching to a new state.

NOTE 3. V_{CM} specifies the maximum allowable range of $(V_{TR} + V_{CP}) / 2$.

Table 5F. AC Characteristics^(1,5), $T_A = -40^{\circ}\text{C}$ to 85°C

Symbol	Parameter	Test Conditions	Minimum	Typical	Maximum	Units
$t_{sk(o)}$	Same Device Output Pin-to-Pin Skew ⁽²⁾				50	ps
$t_{sk(p)}$	Pulse Skew ⁽³⁾				100	ps
$t_{sk(pp)}$	Part-to-Part Skew ⁽⁴⁾				300	ps
t_{PLH}	Propagation Delay, Low-to-High	A Crosspoint to $Q_n/\overline{Q_n}$ Crosspoint		1.5	2.2	ns
t_{PHL}	Propagation Delay, High-to-Low			1.5	2.2	ns
f_o	Frequency Range ⁽⁶⁾				450	MHz
t_{PGE}	Output Gate Enable Crossing V_{THI} -to- $Q_n/\overline{Q_n}$ Crosspoint				3.5	ns
t_{PGD}	Output Gate Enable Crossing V_{THI} -to- $Q_n/\overline{Q_n}$ Crosspoint Driven to GL Designated Level				3.5	ns
t_{PWRDN}	\overline{PD} Crossing V_{THI} -to- $Q_n = V_{DD}$, $\overline{Q_n} = V_{DD}$				100	μS
t_{PWRUP}	Output Gate Disable Crossing V_{THI} to $Q_n/\overline{Q_n}$ Driven to Designated Level				100	μS
t_R / t_F	Output Rise/Fall Time ⁽⁶⁾	20% to 80%	100		500	ps

NOTE: Characterized at 300MHz, unless otherwise noted.

NOTE 1. AC propagation measurements should not be taken within the first 100 cycles of startup.

NOTE 2. Skew measured between crosspoints of all differential output pairs under identical input and output interfaces, transitions and load conditions on any one device.

NOTE 3. Skew measured is the difference between propagation delay times t_{PHL} and t_{PLH} of any differential output pair under identical input and output interfaces, transitions and load conditions on any one device.

NOTE 4. Skew measured is the magnitude of the difference in propagation times between any single differential output pair of two devices, given identical transitions and load conditions at identical V_{DD} levels and temperature.

NOTE 5. All parameters are tested with a 50% input duty cycle.

NOTE 6. Guaranteed by design but not production tested.

Differential AC Timing Waveforms

Output Propagation and Skew Waveforms

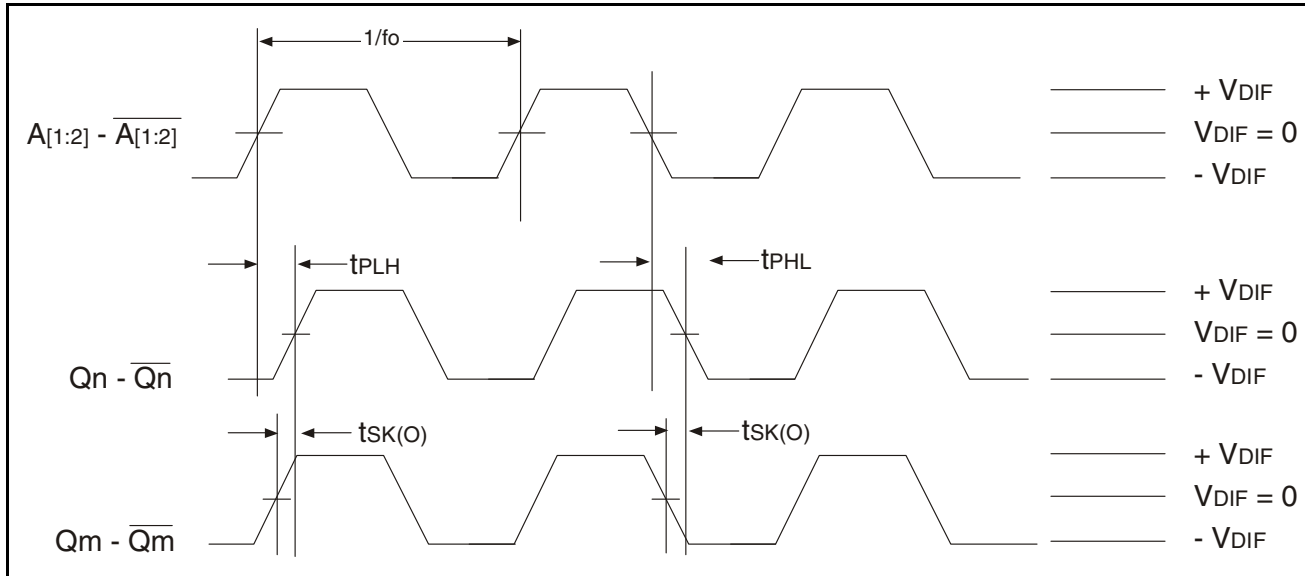

NOTE 1: Pulse skew is calculated using the following expression:

$$tsk(p) = |tp_{HL} - tp_{LH}|$$

Note that the tp_{HL} and tp_{LH} shown above are not valid measurements for this calculation because they are not taken from the same pulse.

NOTE 2: AC propagation measurements should not be taken within the first 100 cycles of startup.

Differential Gate Disabled/Endable Showing Runt Pulse Generation

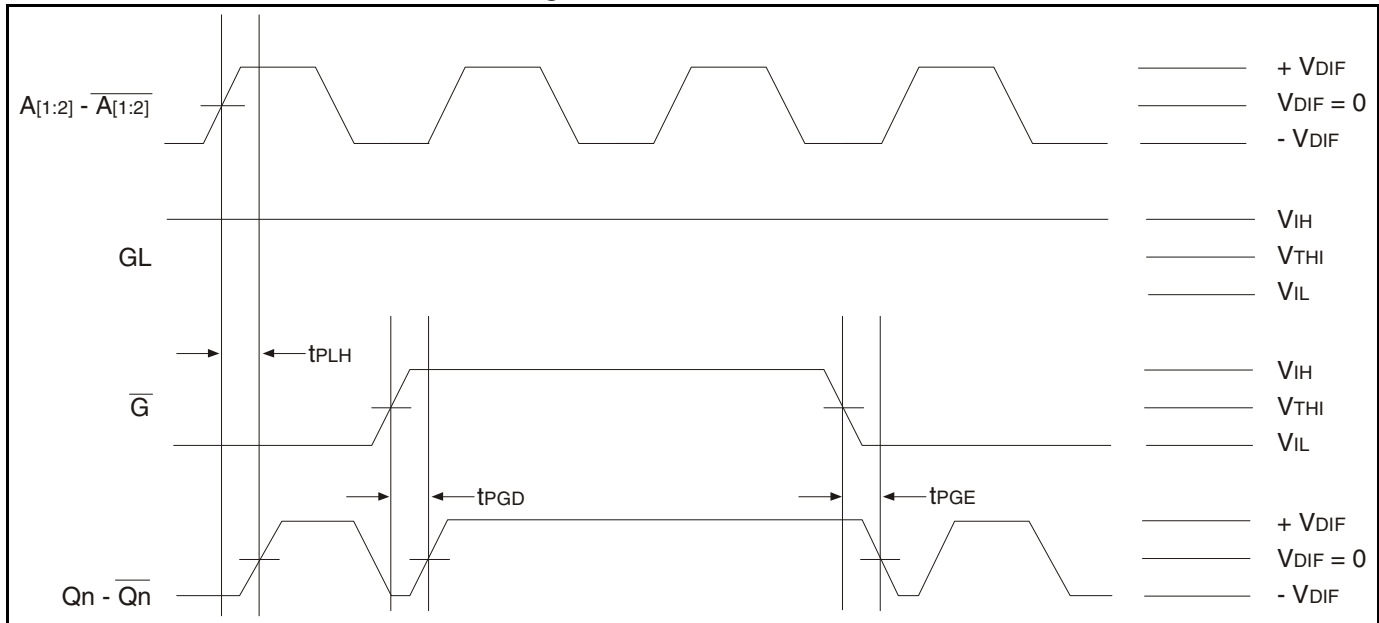

NOTE 1: As shown, it is possible to generate runt pulses on gate disable and enable of the outputs. It is the user's responsibility to time the \bar{G} signal to avoid this problem.

Glitchless Output Operation with Switching Input Clock Selection

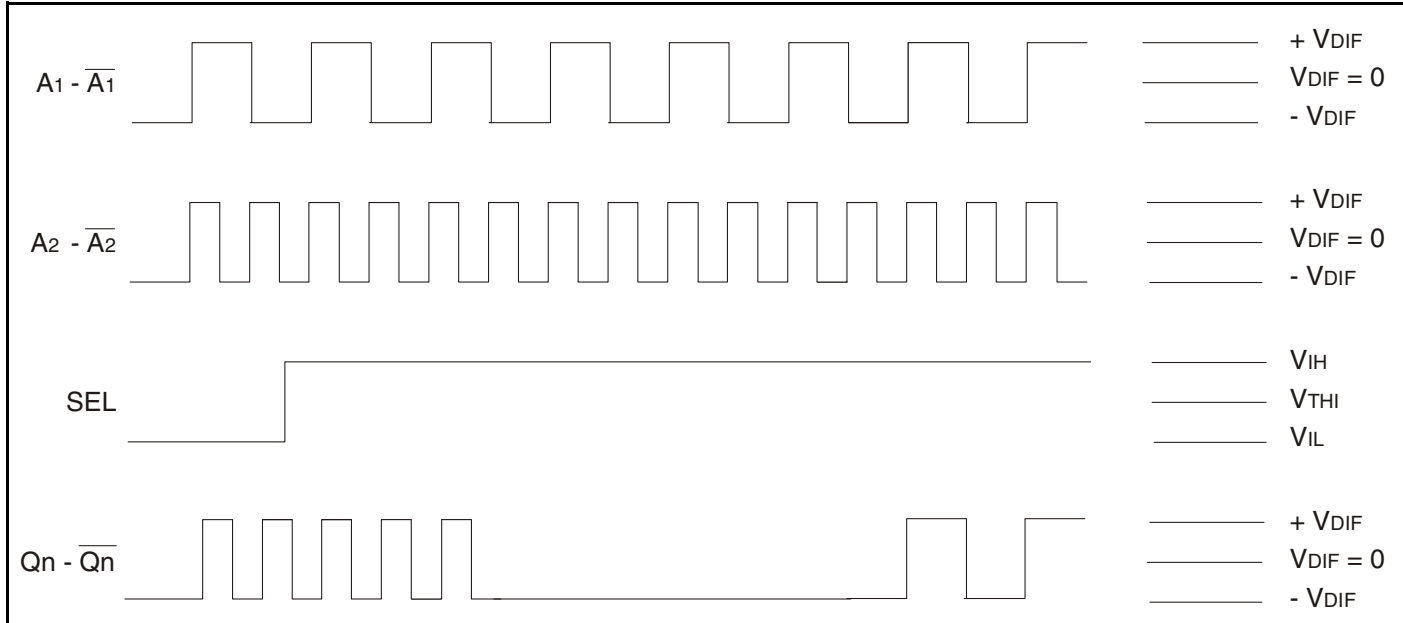

1. When SEL changes, the output clock goes LOW on the falling edge of the output clock up to three cycles later. The output then stays LOW for up to three clock cycles of the new input clock. After this, the output starts with the rising edge of the new input clock.
2. AC propagation measurements should not be taken within the first 100 cycles of startup.

FSEL Operation for When Current Clock Dies

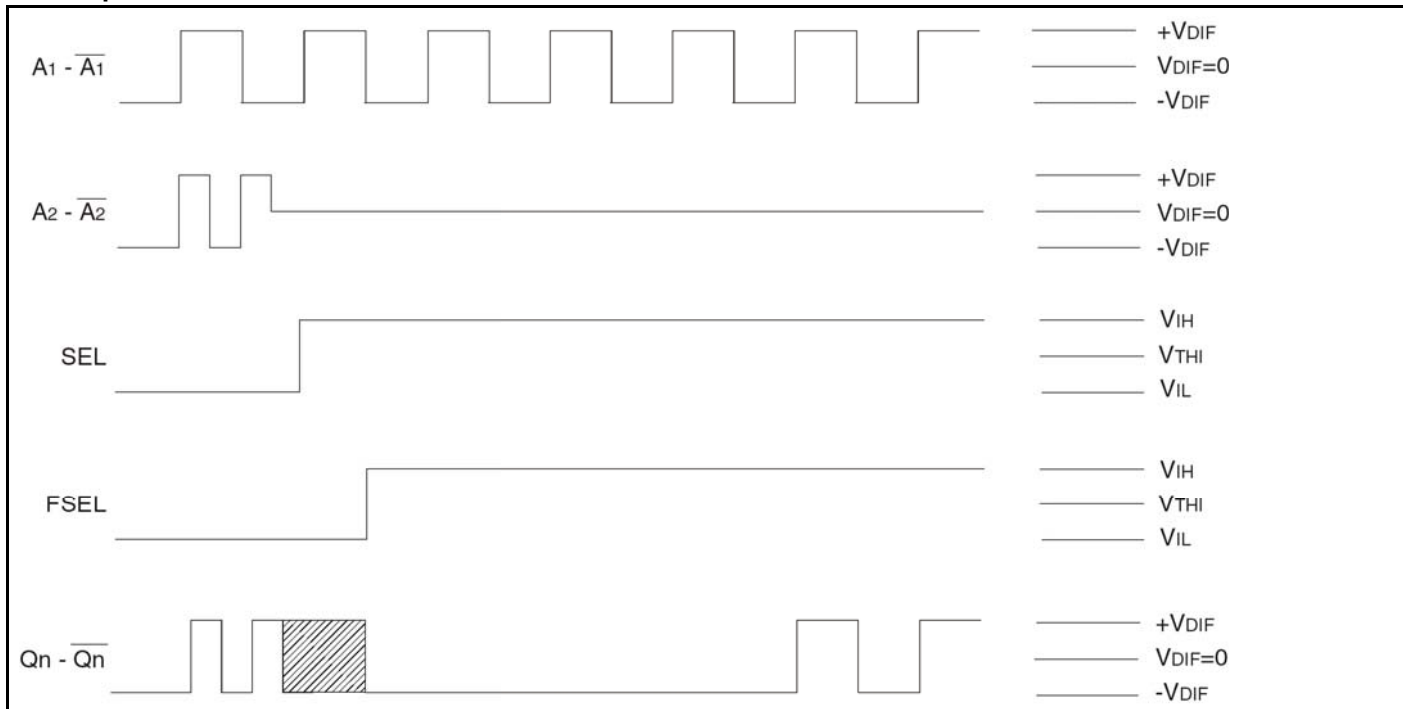

1. When the differential on the selected clock goes below the minimum DC differential, the outputs clock goes to an unknown state. When this happens, the SEL pin should be toggled and FSEL asserted in order to force selection of the new input clock. The output clock will start up after a number of cycles of the newly-selected input clock.
2. The FSEL pin should stay asserted until the problem with the dead clock can be fixed in the system.
3. It is recommended that the FSEL be tied HIGH for systems that use only one input. If this is not possible, the user must guarantee that the unused input have a differential greater than or equal to the minimum DC differential specified in the datasheet.

FSEL Operation for When Opposite Clock Dies

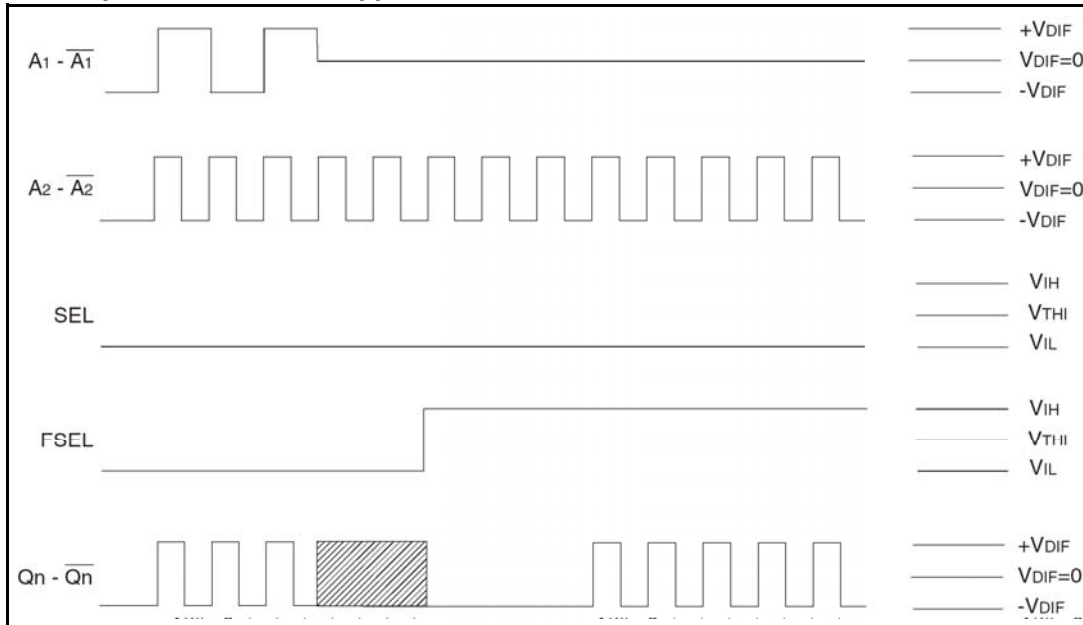

1. When the differential on the non-selected clock goes below the minimum DC differential, the outputs clock goes to an unknown state. When this happens, the FSEL pin should be asserted in order to force selection of the new input clock. The output clock will start up after a number of cycles of the newly-selected input clock.
2. The FSEL pin should stay asserted until the problem with the dead clock can be fixed in the system.
3. It is recommended that the FSEL be tied HIGH for systems that use only one input. If this is not possible, the user must guarantee that the unused input have a differential greater than or equal to the minimum DC differential specified in the datasheet.

Selection of Input While Protecting Against When Opposite Clock Dies

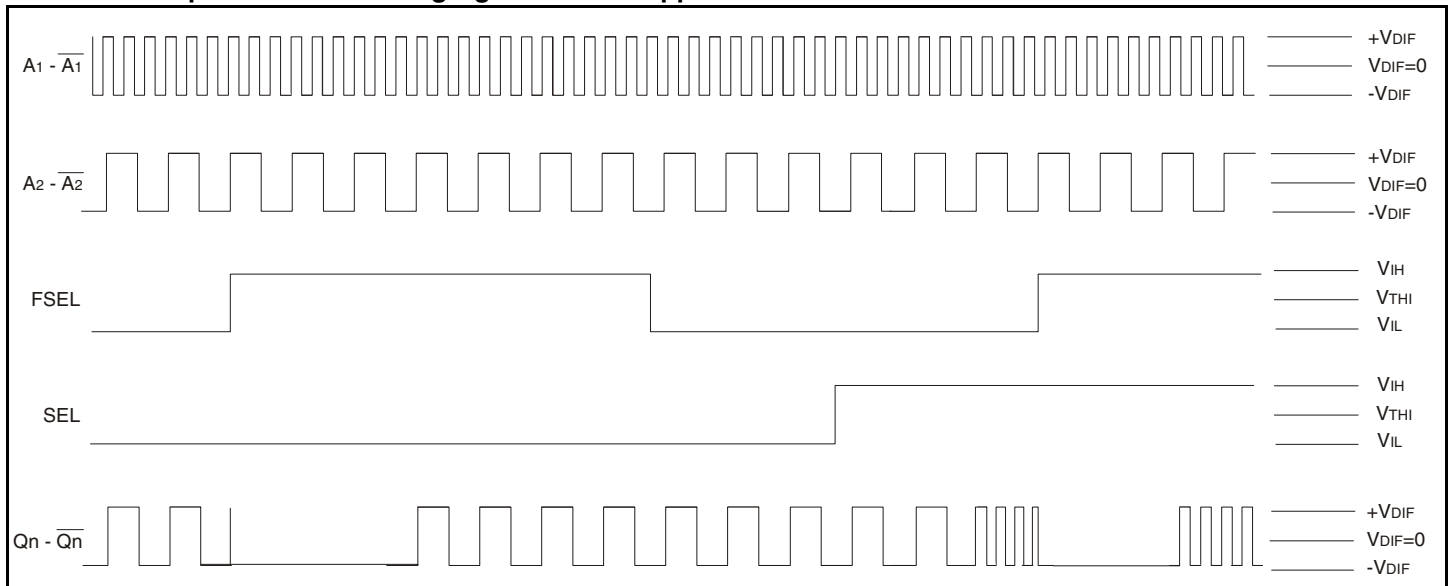

1. If the user holds FSEL HIGH, the output will not be affected by the deselected input clock.
2. The output will immediately be driven to LOW once FSEL is asserted. This may cause glitching on the output. The output will restart with the input clock selected by the SEL pin.
3. If the user decides to switch input clocks, the user must de-assert FSEL, then assert FSEL after toggling the SEL input pin. The output will be driven LOW and will restart with the input clock selected by the SEL pin.

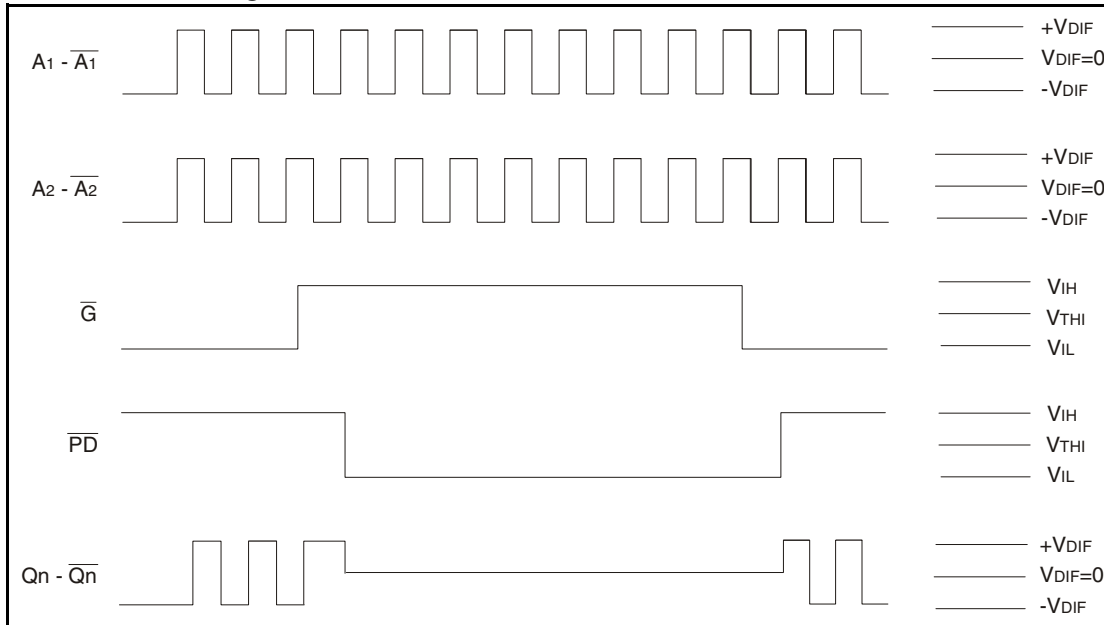
Power Down Timing

NOTE 1: It is recommended that outputs be disabled before entering power-down mode. It is also recommended that the outputs remain disabled until the device completes power-up after asserting \overline{PD} .

NOTE 2: The *Power Down Timing* diagram assumes that GL is HIGH.

NOTE 3: It should be noted that during power-down mode, the outputs are both pulled to V_{DD} . In the *Power Down Timing* diagram this is shown when Qn/ \overline{Qn} goes to $V_{DIF} = 0$.

Test Circuits and Conditions

Test Circuit for Differential Input

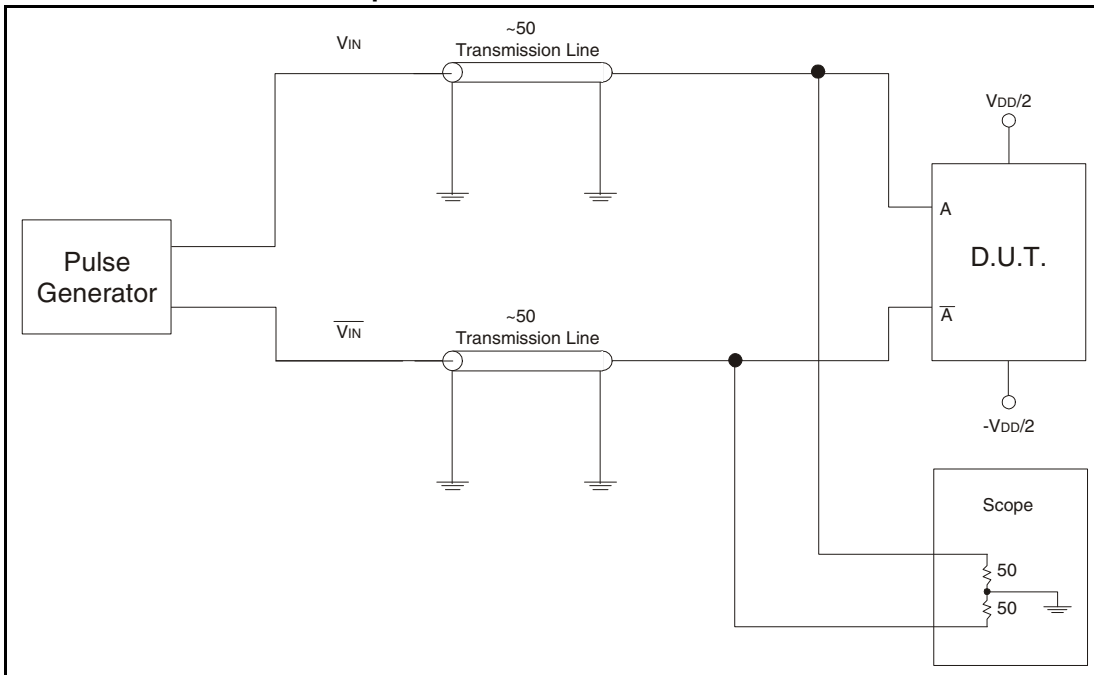
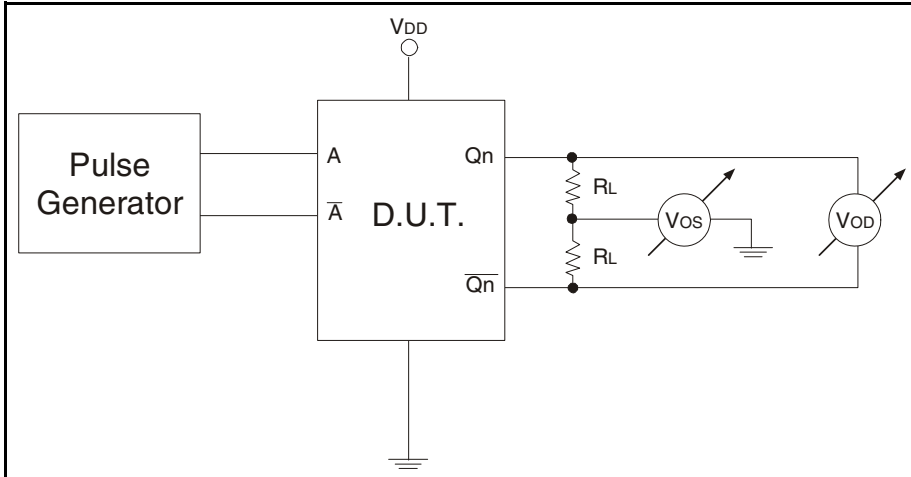
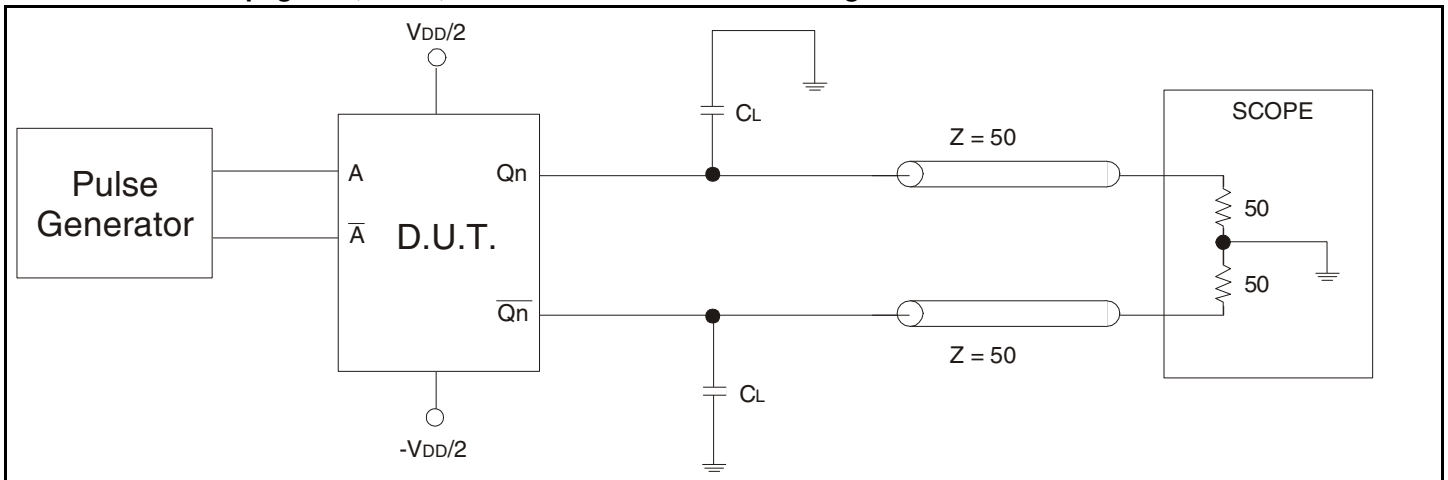

Table 6A. Differential Input Test Conditions

Symbol	$V_{DD} = 2.5V \pm 0.2V$	Unit
V_{THI}	Crossing of A and \overline{A}	V

Test Circuit for DC Outputs and Power Down Tests

Test Circuit for Propagation, Skew, and Gate Enable/Disable Timing

Table 6B. Differential Input Test Conditions

Symbol	$V_{DD} = 2.5V \pm 0.2V$	Unit
C_L	$0^{(1)}$	pF
	$8^{(1,2)}$	pF
R_L	50	Ω

NOTE 1: Specifications only apply to “Normal Operations” test condition. The T_{IA}/E_{IA} specification load is for reference only.

NOTE 2: The scope inputs are assumed to have a 2pF load to ground. $T_{IA}/E_{IA} - 644$ specifies 5pF between the output pair. With $C_L = 8pF$, this gives the test circuit appropriate 5pF equivalent load.

Ordering Information

Table 7. Ordering Information

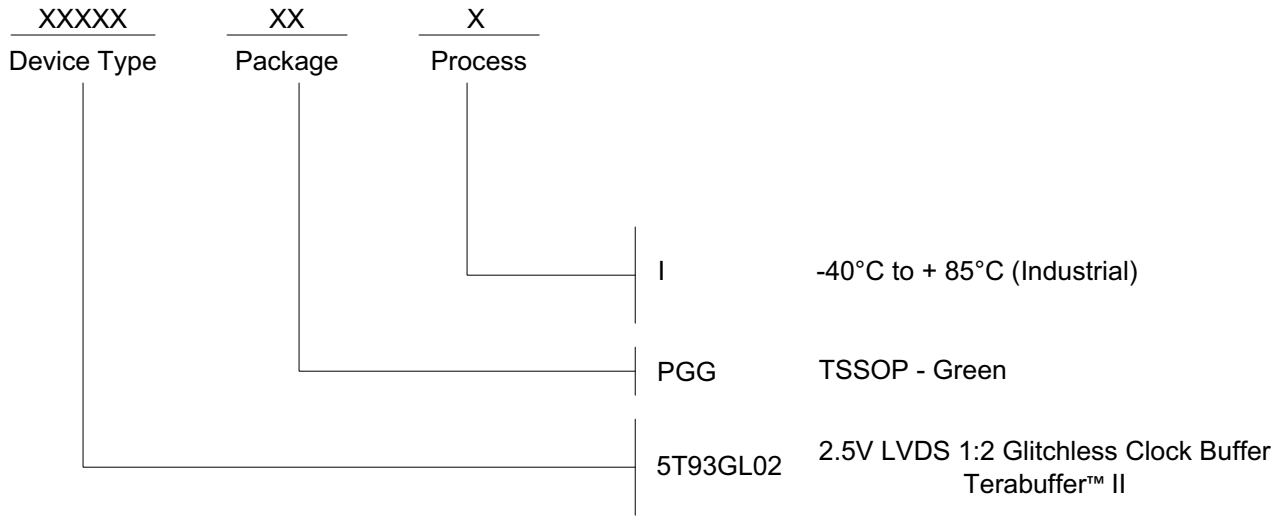

Revision History Sheet

Rev	Table	Page	Description of Change	Date
B	T3A T3B	4 4	Added Gate Control Output Table. Added Input Selection Table. Converted datasheet format.	8/17/09
B	T5F	8 1	Added NOTE: Characterized at 300MHz, unless otherwise noted. NRND - Not Recommended for New designs	1/18/13
B	T7	15	Ordering Information - removed leaded device, PDN N-13-11 Updated data sheet format	3/11/15
B		1	Product Discontinuation Notice - last time buy expires September 7, 2016. PDN N-16-02	3/10/16



Corporate Headquarters
6024 Silver Creek Valley Road
San Jose, CA 95138 USA

Sales
1-800-345-7015 or 408-284-8200
Fax: 408-284-2775
www.IDT.com

Tech Support
email: clocks@idt.com

DISCLAIMER Integrated Device Technology, Inc. (IDT) and its subsidiaries reserve the right to modify the products and/or specifications described herein at any time and at IDT's sole discretion. All information in this document, including descriptions of product features and performance, is subject to change without notice. Performance specifications and the operating parameters of the described products are determined in the independent state and are not guaranteed to perform the same way when installed in customer products. The information contained herein is provided without representation or warranty of any kind, whether express or implied, including, but not limited to, the suitability of IDT's products for any particular purpose, an implied warranty of merchantability, or non-infringement of the intellectual property rights of others. This document is presented only as a guide and does not convey any license under intellectual property rights of IDT or any third parties.

IDT's products are not intended for use in applications involving extreme environmental conditions or in life support systems or similar devices where the failure or malfunction of an IDT product can be reasonably expected to significantly affect the health or safety of users. Anyone using an IDT product in such a manner does so at their own risk, absent an express, written agreement by IDT.

While the information presented herein has been checked for both accuracy and reliability, Integrated Device Technology (IDT) assumes no responsibility for either its use or for the infringement of any patents or other rights of third parties, which would result from its use. No other circuits, patents, or licenses are implied. This product is intended for use in normal commercial applications. Any other applications, such as those requiring extended temperature ranges, high reliability or other extraordinary environmental requirements are not recommended without additional processing by IDT. IDT reserves the right to change any circuitry or specifications without notice. IDT does not authorize or warrant any IDT product for use in life support devices or critical medical instruments.

Integrated Device Technology, IDT and the IDT logo are registered trademarks of IDT. Product specification subject to change without notice. Other trademarks and service marks used herein, including protected names, logos and designs, are the property of IDT or their respective third party owners.

Copyright ©2015 Integrated Device Technology, Inc.. All rights reserved.