

阅读申明

- 1.本站收集的数据手册和产品资料都来自互联网，版权归原作者所有。如读者和版权方有任何异议请及时告之，我们将妥善解决。
- 2.本站提供的中文数据手册是英文数据手册的中文翻译，其目的是协助用户阅读，该译文无法自动跟随原稿更新，同时也可能存在翻译上的不当。建议读者以英文原稿为参考以便获得更精准的信息。
- 3.本站提供的产品资料，来自厂商的技术支持或者使用者的心得体会等，其内容可能存在描述上的差异，建议读者做出适当判断。
- 4.如需与我们联系，请发邮件到marketing@iczoom.com，主题请标有“数据手册”字样。

Read Statement

1. The datasheets and other product information on the site are all from network reference or other public materials, and the copyright belongs to the original author and original published source. If readers and copyright owners have any objections, please contact us and we will deal with it in a timely manner.
2. The Chinese datasheets provided on the website is a Chinese translation of the English datasheets. Its purpose is for reader's learning exchange only and do not involve commercial purposes. The translation cannot be automatically updated with the original manuscript, and there may also be improper translations. Readers are advised to use the English manuscript as a reference for more accurate information.
3. All product information provided on the website refer to solutions from manufacturers' technical support or users the contents may have differences in description, and readers are advised to take the original article as the standard.
4. If you have any questions, please contact us at marketing@iczoom.com and mark the subject with "Datasheets" .



Low Skew Output Buffer

General Description

The ICS9112-26 is a high performance, low skew, low jitter clock driver. It is designed to distribute high speed clocks in PC systems operating at speeds from 0 to 133 MHz.

The ICS9112-26 comes in an eight pin 150 mil SOIC package. It has four output clocks.

Features

- Frequency range 0 - 133 MHz (3.3V)
- Less than 200 ps Jitter between outputs
- Skew controlled outputs
- Skew less than 250 ps between outputs
- Available in 8 pin 150 mil SOIC & 173 mil TSSOP packages.
- 3.3V \pm 10% operation

Block Diagram

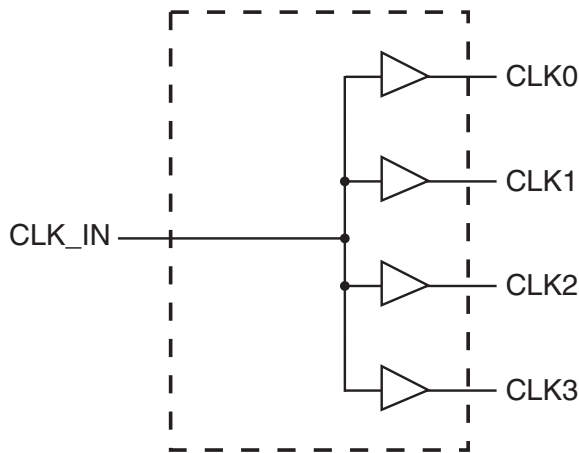

Pin Configuration

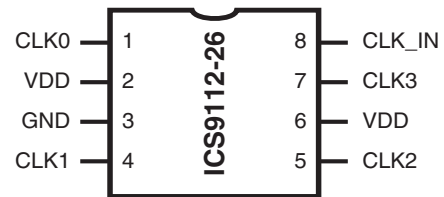

8 pin SOIC & TSSOP

Pin Descriptions

PIN NUMBER	PIN NAME	TYPE	DESCRIPTION
1	CLK0 ¹	OUT	Buffered clock output
2,6	VDD	PWR	Power Supply (3.3V)
3	GND	PWR	Ground
4	CLK1 ¹	OUT	Buffered clock output
5	CLK2 ¹	OUT	Buffered clock output
7	CLK3 ¹	OUT	Buffered clock output
8	CLK_IN	IN	Input reference frequency.

Notes:

1. Weak pull-down on all outputs



Absolute Maximum Ratings

Supply Voltage	7.0 V
Logic Inputs	GND -0.5 V to $V_{DD} + 0.5$ V
Ambient Operating Temperature	0°C to +70°C
Storage Temperature	-65°C to +150°C

Stresses above those listed under *Absolute Maximum Ratings* may cause permanent damage to the device. These ratings are stress specifications only and functional operation of the device at these or any other conditions above those listed in the operational sections of the specifications is not implied. Exposure to absolute maximum rating conditions for extended periods may affect product reliability.

Electrical Characteristics at 3.3V

$T_A = 0 - 70$ °C; Supply Voltage $V_{DD} = 3.3$ V +/-5% (unless otherwise stated)

PARAMETER	SYMBOL	CONDITIONS	MIN	TYP	MAX	UNITS
High-level Output Voltage	V_{OH}	$V_{DD} = \text{min to max}, I_{OH} = -1$ mA	$V_{DD} - 0.2$	3.3		V
		$V_{DD} = 3$ V, $I_{OH} = -24$ mA	2	2.9		V
		$V_{DD} = 3$ V, $I_{OH} = 12$ mA	2.4	3.1		V
Low-level Output Voltage	V_{OL}	$V_{DD} = \text{min to max}, I_{OH} = 1$ mA		0.0055	0.2	V
		$V_{DD} = 3$ V, $I_{OH} = 24$ mA		0.28	0.8	V
		$V_{DD} = 3$ V, $I_{OH} = 12$ mA		0.14	0.55	V
High-level Input Current	I_{OH}	$V_{DD} = 3$ V, $V_O = 1$ V		-61	-50	
		$V_{DD} = 3.3$ V, $V_O = 1.65$ V		-77		
Low-level Input Current	I_{OL}	$V_{DD} = 3$ V, $V_O = 2$ V	60	103		
		$V_{DD} = 3.3$ V, $V_O = 1.65$ V		111		
Input Current	I_I	$V = V_O$ or V_{DD}	-5		5	μA
Input Capacitance ¹	C_I	$V_{DD} = 3.3$ V, $V_I = 0$ V or 3.3 V		3		pF
Output Capacitance ¹	CO	$V_{DD} = 3.3$ V, $V_I = 0$ V or 3.3 V		3.2		pF
Supply current	I_{DD}	REF = 0 MHz		22	50	μA
		Unloaded outputs at 66.67 MHz		25	40	mA

1. Guaranteed by design, not 100% tested in production.

Switching Characteristics at 3.3V

$T_A = 0 - 70$ °C; Supply Voltage $V_{DD} = 3.3$ V +/-5% (unless otherwise stated)

PARAMETER	SYMBOL	CONDITIONS	MIN	TYP	MAX	UNITS
Low-to-high Propagation Delay ¹	t_{PLH}	$V_O = V_{DD}/2$	4	5.6	7	ns
High-to-low Propagation Delay ¹	t_{PHL}	$V_O = V_{DD}/2$	4	5.2	7	ns
Output Skew Window ¹	$T_{sk}(O)$	$V_O = V_{DD}/2$		50	100	ps
Process Skew ¹	$T_{sk}(PR)$	$V_O = V_{DD}/2$			0.5	ps
CLKIN High Time ¹	T_{high}	66 MHz	6			ns
		133 MHz	3			
CLKIN Low Time ¹	T_{low}	66 MHz	6			ns
		133 MHz	3			
Output Rise Slew Rate ¹	T_r	0.3 to 0.6 V_{DD}	2	3.6	5	V/ns
Output Rise Slew Rate ¹	T_f	0.3 to 0.6 V_{DD}	2	3.2	5	V/ns

1. Guaranteed by design, not 100% tested in production.

Notes:

- Guaranteed by design and characterization. Not subject to 100% test.
- CLK_IN input has a threshold voltage of 1.4V
- All parameters expected with loaded outputs

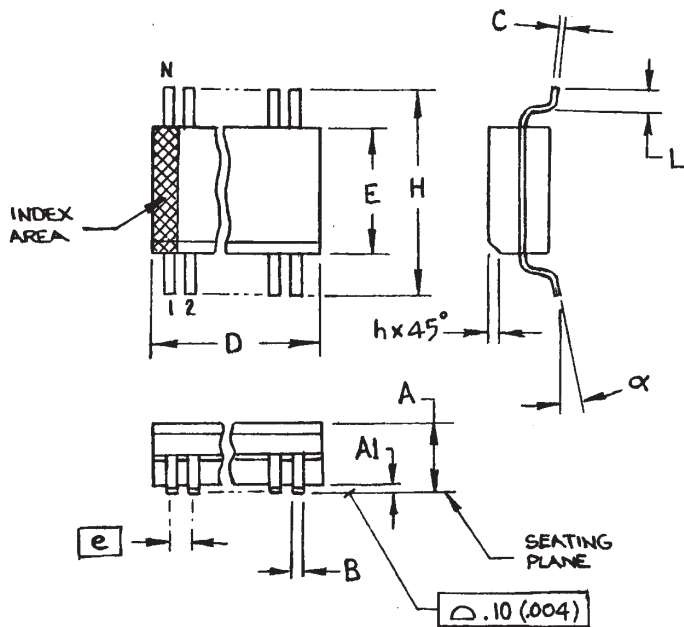

SYMBOL	In Millimeters COMMON DIMENSIONS		In Inches COMMON DIMENSIONS	
	MIN	MAX	MIN	MAX
A	1.35	1.75	.0532	.0688
A1	0.10	0.25	.0040	.0098
B	0.33	0.51	.013	.020
C	0.19	0.25	.0075	.0098
D	SEE VARIATIONS		SEE VARIATIONS	
E	3.80	4.0	.1497	.1574
e	1.27 BASIC		0.050 BASIC	
H	5.80	6.20	.2284	.2440
h	0.25	0.50	.010	.020
L	0.40	1.27	.016	.050
N	SEE VARIATIONS		SEE VARIATIONS	
α	0°	8°	0°	8°

VARIATIONS

N	D mm.		D (inch)	
	MIN	MAX	MIN	MAX
8	4.80	5.00	.1890	.1968

150 mil (Narrow Body) SOIC

Ordering Information

9112yM-26LFT

Example:

XXXX y M - PPP LFT

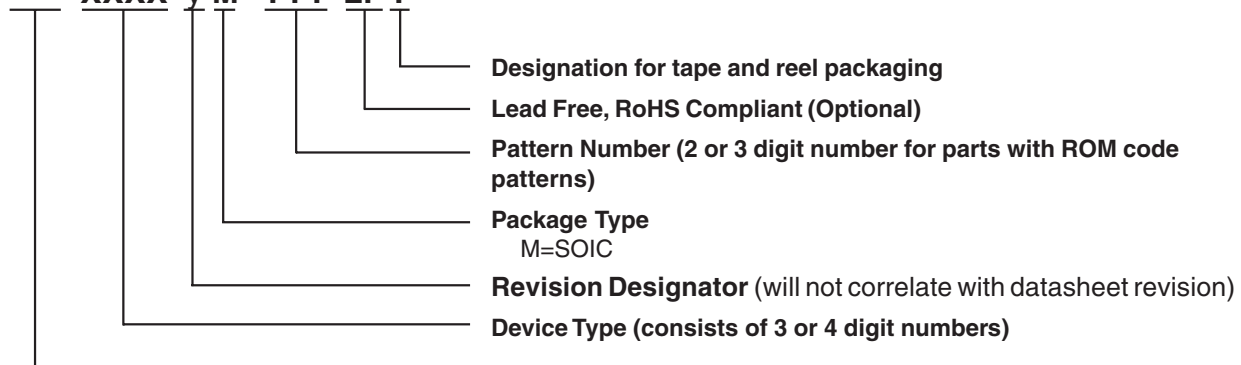

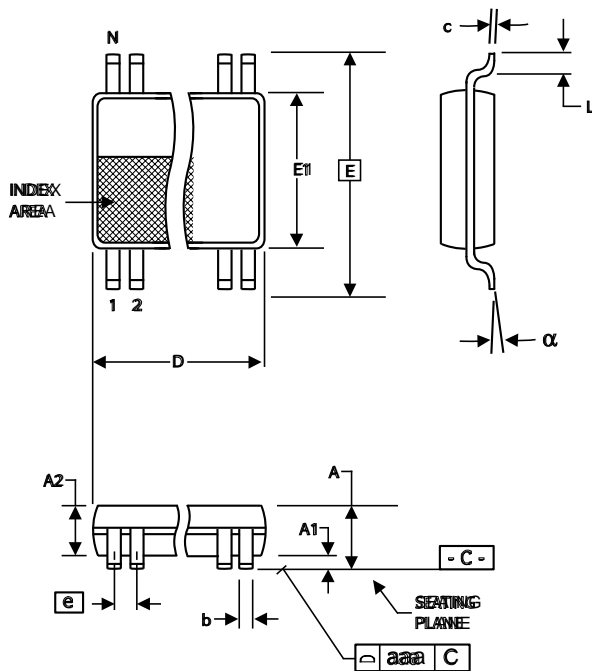

4.40 mm. Body, 0.65 mm. pitch TSSOP
(173 mil) (0.0256 mil)

SYMBOL	In Millimeters COMMON DIMENSIONS		In Inches COMMON DIMENSIONS	
	MIN	MAX	MIN	MAX
A	-	1.20	-	.047
A1	0.05	0.15	.002	.006
A2	0.80	1.05	.032	.041
b	0.19	0.30	.007	.012
c	0.09	0.20	.0035	.008
D	SEE VARIATIONS		SEE VARIATIONS	
E	6.40 BASIC		0.252 BASIC	
E1	4.30	4.50	.169	.177
e	0.65 BASIC		0.0256 BASIC	
L	0.45	0.75	.018	.030
N	SEE VARIATIONS		SEE VARIATIONS	
alpha	0°	8°	0°	8°
aaa	-	0.10	-	.004

VARIATIONS

N	D mm.		D (inch)	
	MIN	MAX	MIN	MAX
8	2.90	3.10	.114	.122

MO-153 JEDEC 7/6/00 Rev B
Doc.# 10-0038

Ordering Information

9112yG-26LFT

Example:

XXXX y G - PPP LFT

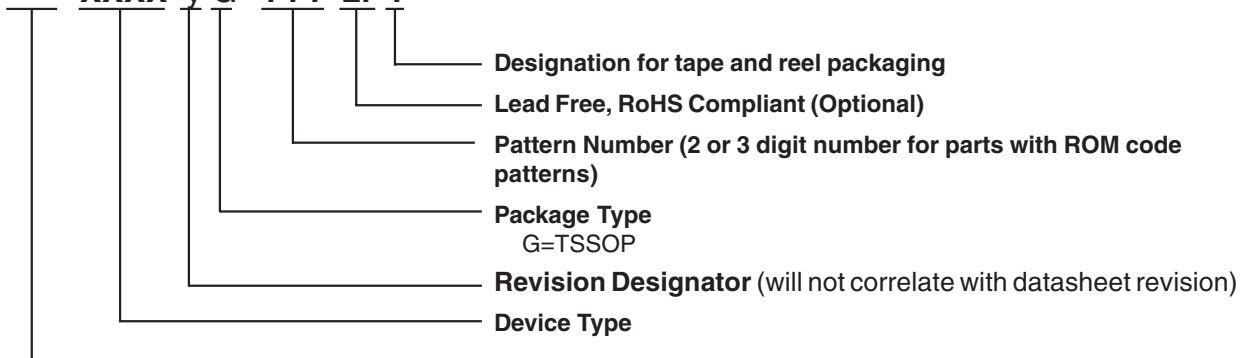



Revision History

Rev.	Issue Date	Description	Page #
C	04/17/07	Added LF to Ordering Information.	-
D	05/14/07	Updated Ordering Information.	3-4