

## 阅读申明

- 1.本站收集的数据手册和产品资料都来自互联网，版权归原作者所有。如读者和版权方有任何异议请及时告之，我们将妥善解决。
- 2.本站提供的中文数据手册是英文数据手册的中文翻译，其目的是协助用户阅读，该译文无法自动跟随原稿更新，同时也可能存在翻译上的不当。建议读者以英文原稿为参考以便获得更精准的信息。
- 3.本站提供的产品资料，来自厂商的技术支持或者使用者的心得体会等，其内容可能存在描述上的差异，建议读者做出适当判断。
- 4.如需与我们联系，请发邮件到marketing@iczoom.com，主题请标有“数据手册”字样。

## Read Statement

1. The datasheets and other product information on the site are all from network reference or other public materials, and the copyright belongs to the original author and original published source. If readers and copyright owners have any objections, please contact us and we will deal with it in a timely manner.
2. The Chinese datasheets provided on the website is a Chinese translation of the English datasheets. Its purpose is for reader's learning exchange only and do not involve commercial purposes. The translation cannot be automatically updated with the original manuscript, and there may also be improper translations. Readers are advised to use the English manuscript as a reference for more accurate information.
3. All product information provided on the website refer to solutions from manufacturers' technical support or users the contents may have differences in description, and readers are advised to take the original article as the standard.
4. If you have any questions, please contact us at marketing@iczoom.com and mark the subject with "Datasheets" .

## PLL Synthesizer with 3-Wire Bus for TV Tuner

### DESCRIPTION

The NJW1503A is a PLL frequency synthesizer especially designed for TV and VCR tuning systems and consists of PLL circuit and a prescaler which operates up to 1.0GHz, built into one chip.

The NJW1503A is controlled through a 3-wire bus.

### PACKAGE OUTLINE

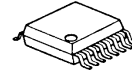

NJW1503AV

### FEATURES

- Operating Voltage 5V
- Low Operating Current : 15mA typ. @Vcc=5V
- Prescaler accepts frequencies up to 1GHz on chip
- 3-wire bus controlled
- Reference divider ratio automatic setting (512 or 1024)
- 34V max. tuning voltage output
- Package Outline: SSOP16

### BLOCK DIAGRAM

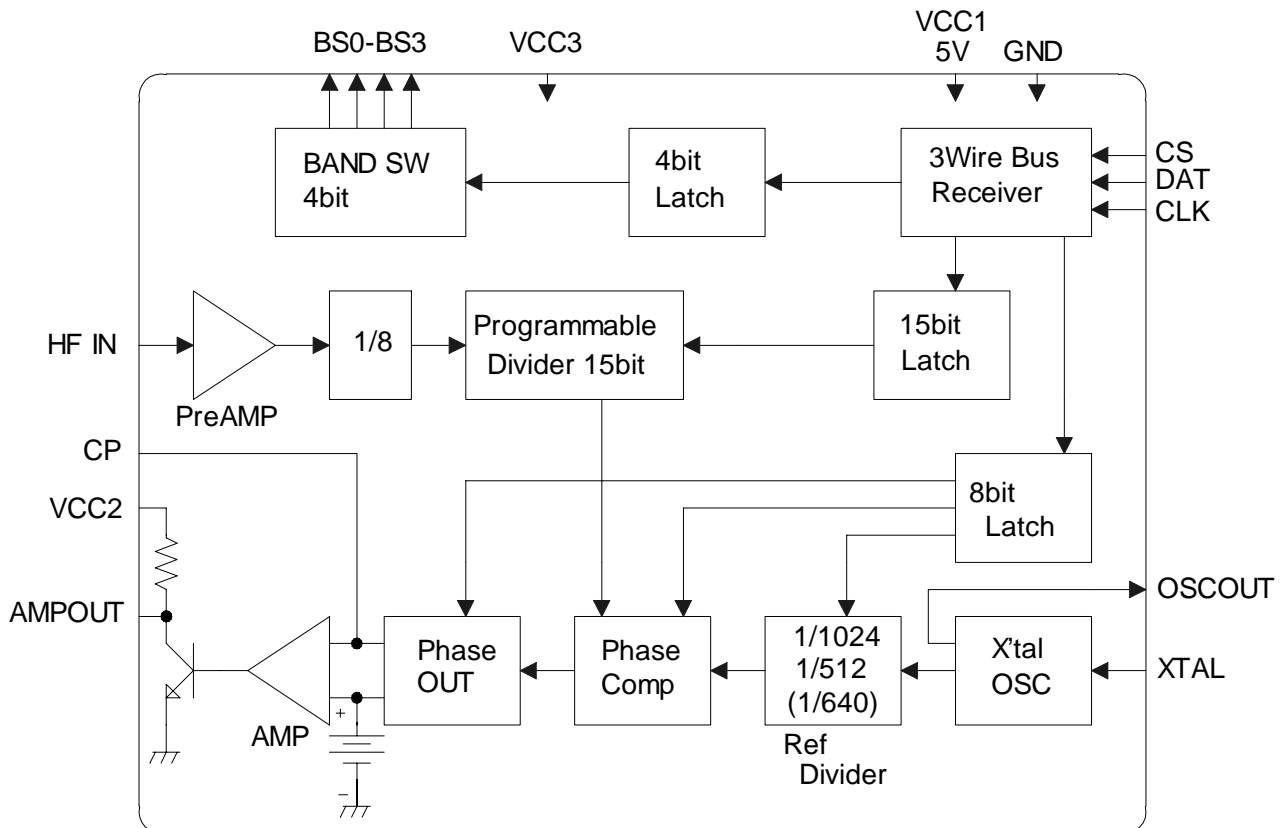

## ■ ABSOLUTE MAXIMUM RATINGS

( $T_A=25^\circ\text{C}$ )

Parameter	Symbol	Ratings	Unit
Supply Voltage (Vcc1,3)	Vcc1,Vcc3	-0.3 to +6.5	V
Supply Voltage (Vcc2)	Vcc2	-0.3 to +34	V
Input Voltage(except 3-wire bus)	V <sub>i</sub>	-0.3 to Vcc+0.3	V
Output Voltage (except 3-wire bus)	V <sub>o</sub>	-0.3 to Vcc+0.3	V
3-Wire bus Input Voltage	V <sub>seri</sub>	-0.3 to 6.5	V
Power Dissipation	P <sub>D</sub>	300	mW
Operating Temperature Range	T <sub>opr</sub>	-20 to +75	°C
Storage Temperature Range	T <sub>stg</sub>	-40 to +125	°C

## ■ RECOMMENDED OPERATING CONDITION

( $T_A=25^\circ\text{C}$ )

Parameter	Condition	Symbol	Min.	Typ.	Max.	Unit
Operating Voltage	Vcc1,Vcc3	V <sup>+1</sup> ,V <sup>+3</sup>	4.5	5	5.5	V
Operating Voltage	Vcc2	V <sup>+2</sup>	0	32	34	V
X'tal Operating Range		f <sub>xtal</sub>	3.15	4	4.05	MHz
HF Input Frequency	Input= -20dBm	f <sub>hf</sub>	80	-	1000	MHz
Data Set-up Time	Refer to 3-Wire bus Timing Chart	t <sub>SET</sub>	2	-	-	uS
Clock Width Time		t <sub>CLK</sub>	2	-	-	uS
Data Hold Time		t <sub>HOLD</sub>	2	-	-	uS
CS Set-up Time		t <sub>CSSET</sub>	10	-	-	uS
CS Hold Time		t <sub>CSHLD</sub>	2	-	-	uS
Maximum Clock Frequency		Refer to 3-Wire bus Timing Chart F <sub>CLKMAX</sub> =1/T <sub>CLKMAX</sub>	t <sub>CLKMAX</sub>	-	-	100

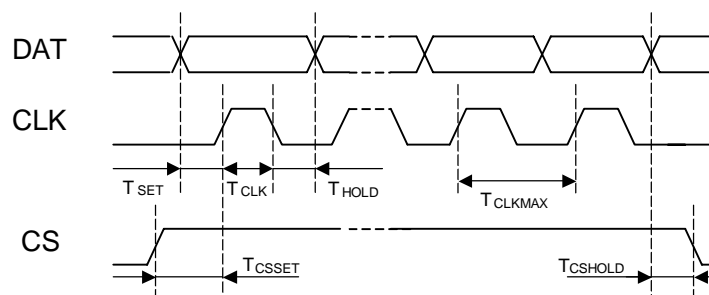

3-Wire bus Timing Chart

V<sub>IHmin</sub>(0.7 Vcc1) and V<sub>IHmax</sub>(0.3 Vcc1)

## ■ ELECTRICAL CHARACTERISTICS

(V<sub>CC1,3</sub>=5V, V<sub>CC2</sub>=32V, T<sub>A</sub>=25°C)

Parameter	Condition	Symbol	Min.	Typ.	Max.	Unit
Operating Current 1	f <sub>HF</sub> =100MHz	I <sub>CC</sub>	6	15	23	mA
Operating Current 2	AMP OUT: Low Level	I <sub>CC2</sub>	-	1.6	-	mA
AMP Input Current	Phase OUT :High Imp (2.5V)	I <sub>IN</sub>	(-50)	0.1	(50)	nA
AMP Output Current	AMP OUT : Low Level AMP OUT Input=5V	I <sub>OUT</sub>	-	-	-2.5	mA
AMP Gain	f=1KHz	AV	40	50	60	dB
Phase Comparator Current	Current Source	I <sub>source</sub>	190	280	400	uA
Phase Comparator Current	Current Sink	I <sub>sink</sub>	-400	-280	-190	uA
Band Switch						
"L" Output Current	BS0=BS1=BS2=0.3V	I <sub>OBS0-2L</sub>	-5.0	-0.5	0.0	mA
"H" Output Current	BS0=BS1=BS2=4.7V	I <sub>OBS0-2H</sub>	11.0	15.0	-	mA
"L" Output Current	BS=0.3V	I <sub>OBS3L</sub>	-6.0	-1.0	-0.4	mA
"H" Output Current	BS3=4.7V	I <sub>OBS3H</sub>	0.7	3.5	-	mA
3-Wire bus						
"H" Input Current	CLK, DAT, CS Terminal	I <sub>INH</sub>	-5	0	5	uA
"L" Input Current	CLK, DAT, CS Terminal	I <sub>INL</sub>	-5	0	5	uA
"H" Input Voltage Range	CLK, DAT, CS Terminal	V <sub>IH</sub>	4.0	-	5.0	V
"L" Input Voltage Range	CLK, DAT, CS Terminal	V <sub>IL</sub>	0	-	1.0	V

# NJW1503A

## ■ TEST CIRCUIT

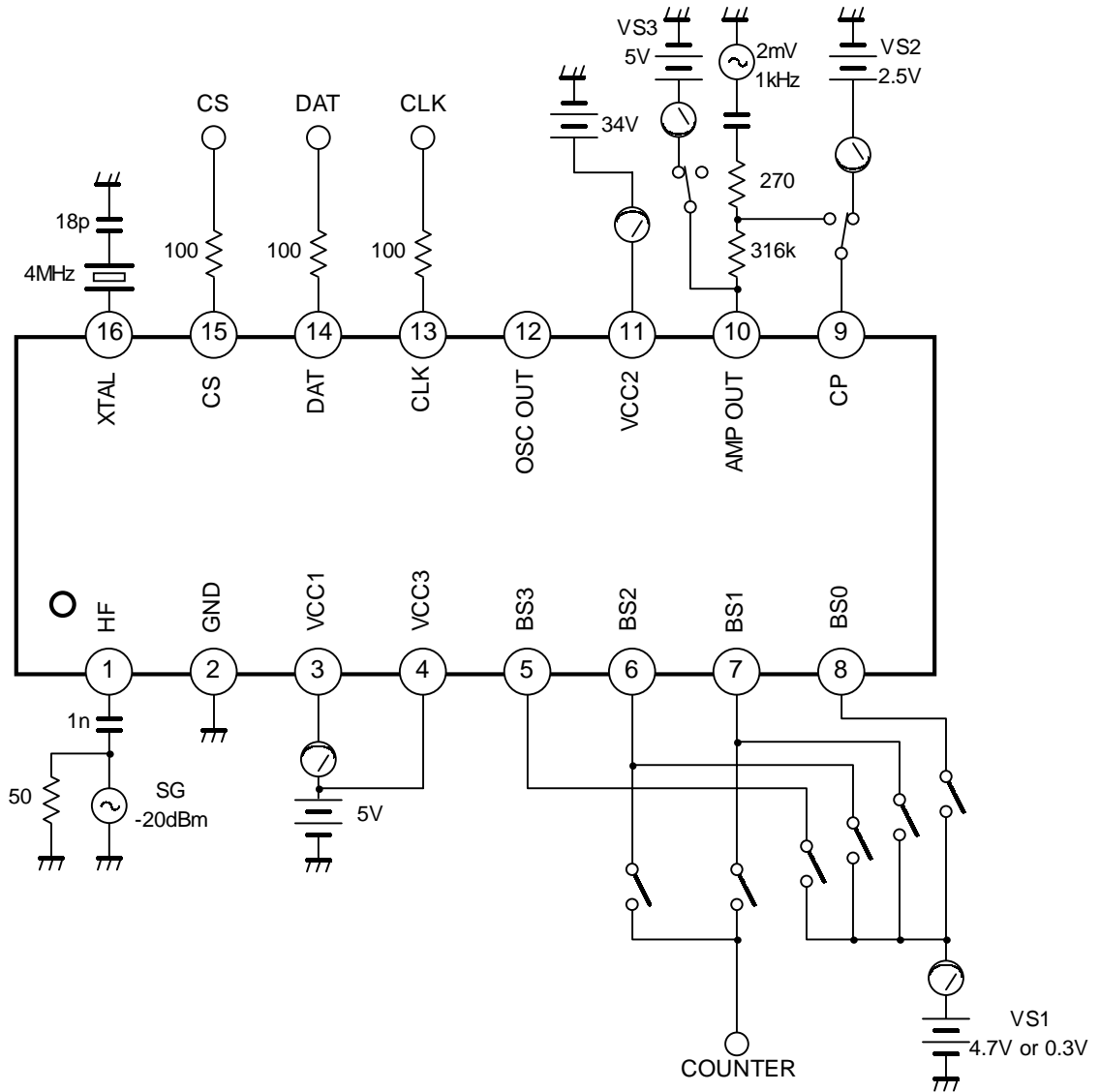

■ Serial Bus Data Format (3-Wire bus)

1. Bus protocol for 18bit

B3 B2 B1 B0 N13 N12 N11 N10 N9 N8 N7 N6 N5 N4 N3 N2 N1 N0

Reference divider :  $f_{xtal} / 512$

2. Bus protocol for 19bit

B3 B2 B1 B0 N14 N13 N12 N11 N10 N9 N8 N7 N6 N5 N4 N3 N2 N1 N0

Reference divider :  $f_{xtal} / 1024$

3. Bus protocol for Test (27bit)

B3 B2 B1 B0 N14 N13 ...N1 N0 T7 T6 T5 T4 T3 T2 T1 T0

B0 to B3 : Control of Band Switch

N0 to N14 : Control of Programmable Divider      N14=MSB N0=LSB

Division ratio :  $N = 2^{14} \times N14 + 2^{13} \times N13 + \dots + 2^1 \times N1 + N0$

Maximum division ratio 32767

Minimum division ratio 256

T0 to T7 : Control bit of test

Bit T0: Charge Pump Current

T0	Charge Pump Current	Conditions
0	280uA	Normal, Default
1	60uA	Test

Bit T1 and T2: Output function of Phase Comparator

T2	T1	Phase Comparator	Conditions
0	0	Normal Operation	Normal, Default
0	1	Source	Test
1	1	High Impedance	Test
1	0	Sink	Test

Bit T4: Band Switch Test

T4	Band Switch	Conditions
0	Normal Operation	Normal, Default
1	Test	Test

Bit T5 and T6: Reference Divider

T6	T5	Reference Divider	Condition
0	0	1/512	Normal, Default
0	1	1/1024	
1	*	1/640	

\* : don't care; 0 or 1

The 18bit and 19bit is automatic selector of the reference divider.

T3: unassigned, undefined

(Note)

Default : Power on reset

## ■ TERMINAL CHARACTERISTICS

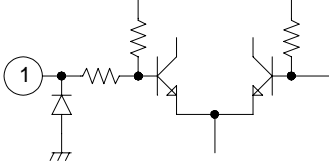
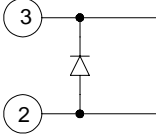
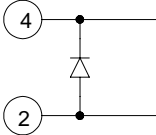
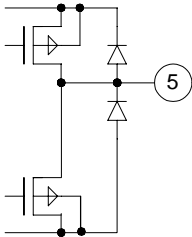
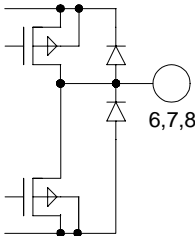
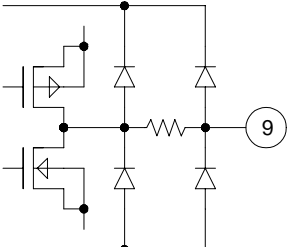
No.	Symbol	Typ.DC Voltage (V)	Equivalent Circuit	Function
1	HF	3.2		High Frequency Signal Input
2	GND	0		GND
3	VCC1	5		Power Supply
4	VCC3	5		Band Switch Power Supply
5	BS3	0		Band Switch
6 7 8	BS2 BS1 BS0	0		Band Switch
9	CP	-		Charge Pump Output

No.	Symbol	Typ.DC Voltage (V)	Equivalent Circuit	Function
10	AMPOUT	-		Amplifier Output
11	VCC2	32		Amplifier Power Supply
12	OSCOUT	4.1		Reference Oscillator Output
13	CLK	-		Clock Input (3-Wire bus)
14	DAT	-		Data Input (3-Wire bus)
15	CS	-		Enable Input (3-Wire bus)
16	XTAL	3.3		Crystal Input



## ■ TYPICAL CHARACTERISTICS

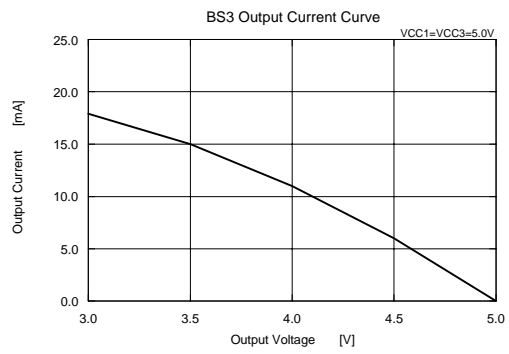
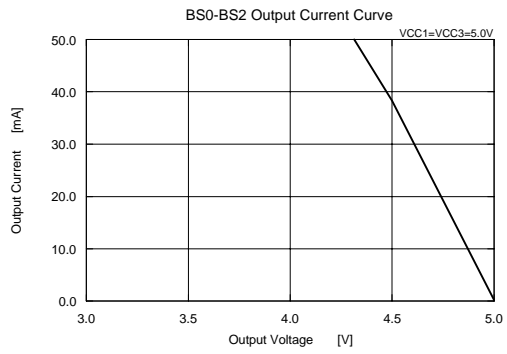
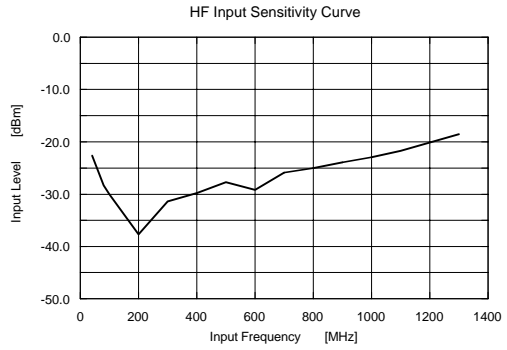
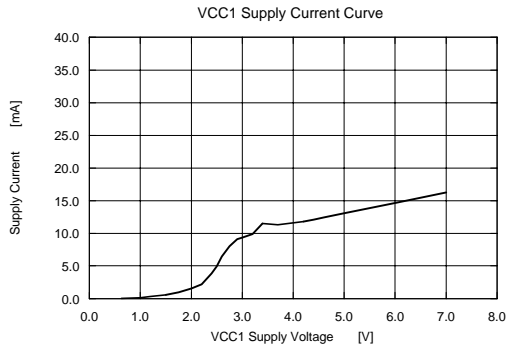

---

# MEMO

**[CAUTION]**

The specifications on this databook are only given for information, without any guarantee as regards either mistakes or omissions. The application circuits in this databook are described only to show representative usages of the product and not intended for the guarantee or permission of any right including the industrial rights.