

阅读申明

- 1.本站收集的数据手册和产品资料都来自互联网，版权归原作者所有。如读者和版权方有任何异议请及时告之，我们将妥善解决。
- 2.本站提供的中文数据手册是英文数据手册的中文翻译，其目的是协助用户阅读，该译文无法自动跟随原稿更新，同时也可能存在翻译上的不当。建议读者以英文原稿为参考以便获得更精准的信息。
- 3.本站提供的产品资料，来自厂商的技术支持或者使用者的心得体会等，其内容可能存在描述上的差异，建议读者做出适当判断。
- 4.如需与我们联系，请发邮件到marketing@iczoom.com，主题请标有“数据手册”字样。

Read Statement

1. The datasheets and other product information on the site are all from network reference or other public materials, and the copyright belongs to the original author and original published source. If readers and copyright owners have any objections, please contact us and we will deal with it in a timely manner.
2. The Chinese datasheets provided on the website is a Chinese translation of the English datasheets. Its purpose is for reader's learning exchange only and do not involve commercial purposes. The translation cannot be automatically updated with the original manuscript, and there may also be improper translations. Readers are advised to use the English manuscript as a reference for more accurate information.
3. All product information provided on the website refer to solutions from manufacturers' technical support or users the contents may have differences in description, and readers are advised to take the original article as the standard.
4. If you have any questions, please contact us at marketing@iczoom.com and mark the subject with "Datasheets" .



MB88152A

Spread Spectrum Clock Generator

MB88152A is a clock generator for EMI (Electro Magnetic Interference) reduction. The peak of unnecessary radiation noise (EMI) can be attenuated by making the oscillation frequency slightly modulate periodically with the internal modulator. It corresponds to both of the center spread which modulates input frequency as Middle Centered and down spread which modulates so as not to exceed input frequency.

Features

- Input frequency : 16.6 MHz to 134 MHz
- Output frequency : 16.6 MHz to 134 MHz
- Modulation rate : $\pm 0.5\%$, $\pm 1.5\%$ (Center spread), $- 1.0\%$, $- 3.0\%$ (Down spread)
- Equipped with oscillation circuit: Range of oscillation 16.6 MHz to 48 MHz
- Modulation clock output Duty : 40% to 60%
- Modulation clock Cycle-Cycle Jitter : Less than 100 ps
- Low current consumption by CMOS process : 5.0 mA (24 MHz : Typ-sample, no load)
- Power supply voltage : 3.3 V \pm 0.3 V
- Operating temperature : $- 40^{\circ}$ to $+85^{\circ}$ C
- Package : SOP 8-pin

Contents

Product Line-up	3	Output Clock Duty Cycle ($t_{DCC} = t_b/t_a$)	15
Pin Assignment	3	Input Frequency ($f_{in} = 1/t_{in}$)	15
Pin Description	3	Output Slew Rate (SR)	15
I/O Circuit Type	4	Cycle-cycle Jitter ($t_{JC} = t_n - t_{n+1}$)	15
Handling Devices	5	Modulation Waveform	16
Block Diagram	6	Lock-up Time	17
Pin Setting	7	Oscillation Circuit	18
Modulation enable setting	7	Interconnection Circuit Example	19
SEL modulation rate setting	7	Example Characteristics	20
Frequency setting	7	Ordering Information	21
Absolute Maximum Ratings	9	Package Dimension	22
Recommended Operating Conditions	10	Document History	23
Electrical Characteristics	12	Sales, Solutions, and Legal Information	24
DC Characteristics	12		
AC Characteristics	13		

1. Product Line-up

MB88152A has three kinds of input frequency, and two kinds of modulation type (center/down spread), total six line-ups.

Product	Input/Output Frequency	Modulation type	Modulation enable pin
MB88152A-100	16.6 MHz to 134 MHz	Down spread	No
MB88152A-101	16.6 MHz to 67 MHz		Yes
MB88152A-102	40 MHz to 134 MHz		
MB88152A-110	16.6 MHz to 134 MHz	Center spread	No
MB88152A-111	16.6 MHz to 67 MHz		Yes
MB88152A-112	40 MHz to 134 MHz		

2. Pin Assignment

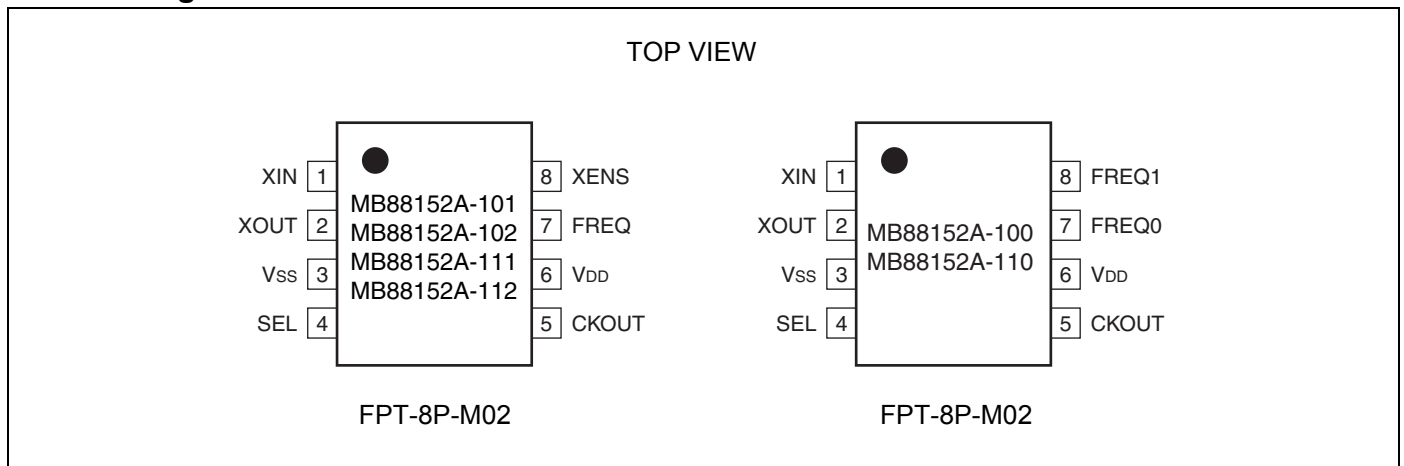

3. Pin Description

Pin name	I/O	Pin no.	Description
XIN	I	1	Crystal resonator connection pin/clock input pin
XOUT	O	2	Crystal resonator connection pin
V _{SS}	—	3	GND pin
SEL	I	4	Modulation rate setting pin
CKOUT	O	5	Modulated clock output pin
V _{DD}	—	6	Power supply voltage pin
FREQ/FREQ0	I	7	Frequency setting pin
XENS/FREQ1	I	8	Modulation enable setting pin/frequency setting pin

4. I/O Circuit Type

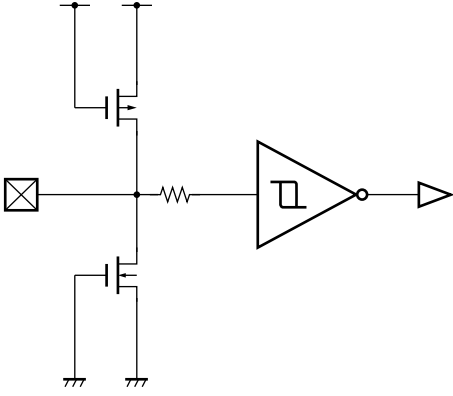
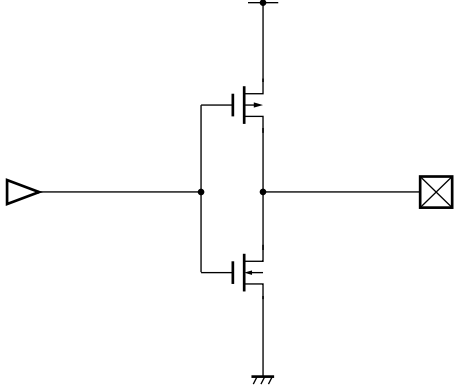
Pin	Circuit type	Remarks
SEL FREQ FREQ0 FREQ1 XENS		CMOS hysteresis input
CKOUT		<ul style="list-style-type: none"> ■ CMOS output ■ I_{OL} = 4 mA

Note: For XIN and XOUT pins, refer to “Oscillation Circuit”.

5. Handling Devices

Preventing Latch-up

A latch-up can occur if, on this device, (a) a voltage higher than V_{DD} or a voltage lower than V_{SS} is applied to an input or output pin or (b) a voltage higher than the rating is applied between V_{DD} and V_{SS} pins. The latch-up, if it occurs, significantly increases the power supply current and may cause thermal destruction of an element. When you use this device, be very careful not to exceed the maximum rating.

Handling unused pins

- Do not leave an unused input pin open, since it may cause a malfunction. Handle by, using a pull-up or pull-down resistor.
- Unused output pin should be opened.

The attention when the external clock is used

- Input the clock to XIN pin, and XOUT pin should be opened when you use the external clock.
- Please pay attention so that an overshoot and an undershoot do not occur to an input clock of XIN pin.

Power supply pins

- Please design connecting the power supply pin of this device by as low impedance as possible from the current supply source.
- We recommend connecting electrolytic capacitor (about 10 μF) and the ceramic capacitor (about 0.01 μF) in parallel between V_{SS} and V_{DD} pins near the device, as a bypass capacitor.

Oscillation Circuit

- Noise near the XIN and XOUT pins may cause the device to malfunction. Design printed circuit boards so that electric wiring of XIN or XOUT pin and resonator (or ceramic oscillator) do not intersect other wiring.
- Design the printed circuit board that surrounds the XIN and XOUT pins with ground.

6. Block Diagram

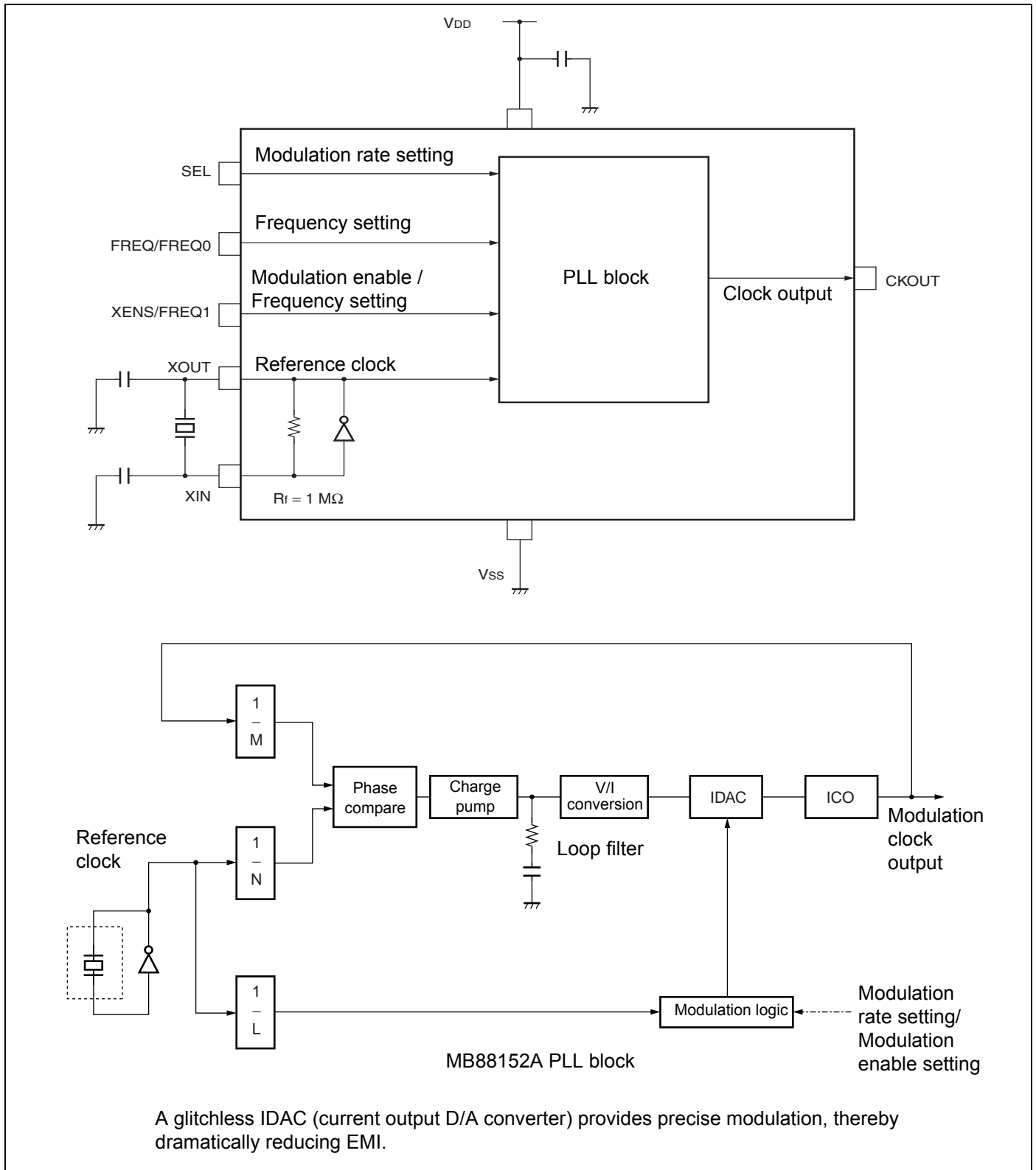

7. Pin Setting

When changing the pin setting, the stabilization wait time for the modulation clock is required. The stabilization wait time for the modulation clock takes the maximum value of Lock-Up time in “AC Characteristics of Electrical Characteristics”.

7.1 Modulation enable setting

XENS	Modulation	
L	Modulation	MB88152A-101, MB88152A-102, MB88152A-111, MB88152A-112
H	No modulation	

Note: MB88152A-100 and MB88152A-110 do not have XENS pin.

7.2 SEL modulation rate setting

SEL	Modulation rate		Remarks
L	$\pm 0.5\%$	MB88152A-110, MB88152A-111, MB88152A-112	Center spread
	$- 1.0\%$	MB88152A-100, MB88152A-101, MB88152A-102	Down spread
H	$\pm 1.5\%$	MB88152A-110, MB88152A-111, MB88152A-112	Center spread
	$- 3.0\%$	MB88152A-100, MB88152A-101, MB88152A-102	Down spread

Note: The modulation rate can be changed at the level of the terminal.

7.3 Frequency setting

FREQ	Frequency	
L	16.6 MHz to 40 MHz	MB88152A-101, MB88152A-111
	40 MHz to 80 MHz	MB88152A-102, MB88152A-112
H	33 MHz to 67 MHz	MB88152A-101, MB88152A-111
	66 MHz to 134 MHz	MB88152A-102, MB88152A-112

Note: MB88152A-100 and MB88152A-110 do not have FREQ pin.

FREQ1	FREQ0	Frequency	
L	L	16.6 MHz to 40 MHz	MB88152A-100, MB88152A-110
L	H	33 MHz to 67 MHz	
H	L	40 MHz to 80 MHz	
H	H	66 MHz to 134 MHz	

Note: MB88152A-101, MB88152A-111, MB88152A-102 and MB88152A-112 have neither FREQ0 pin nor FREQ1 pin.

7.3.1 Center spread

Spectrum is spread (modulated) by centering on the input frequency.

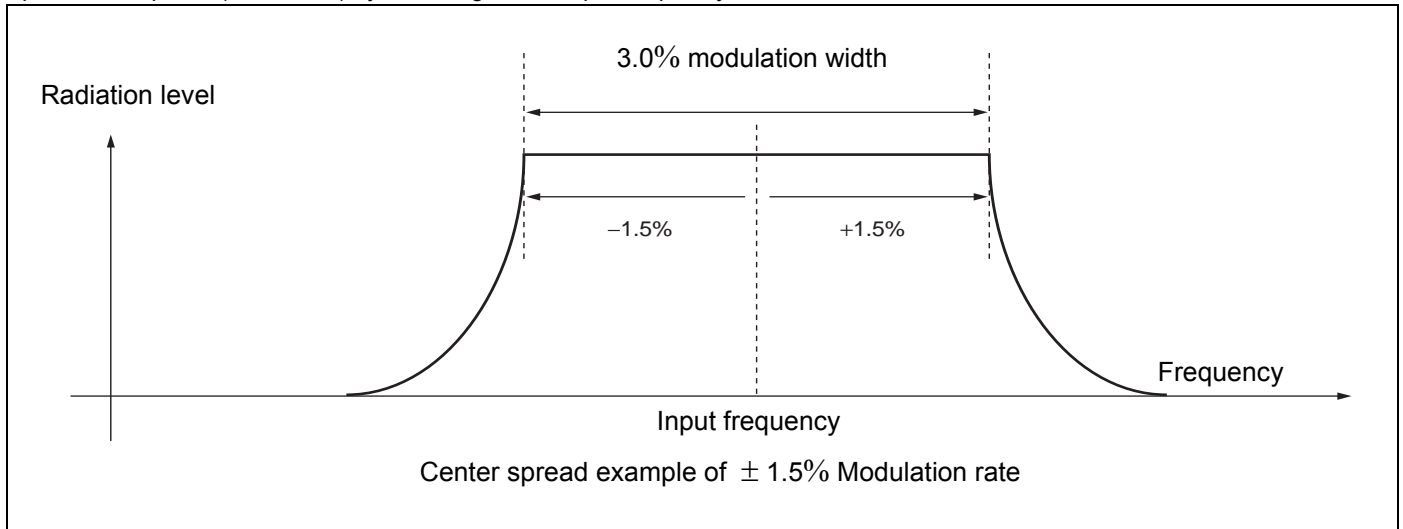

7.3.2 Down spread

Spectrum is spread (modulated) below the input frequency.

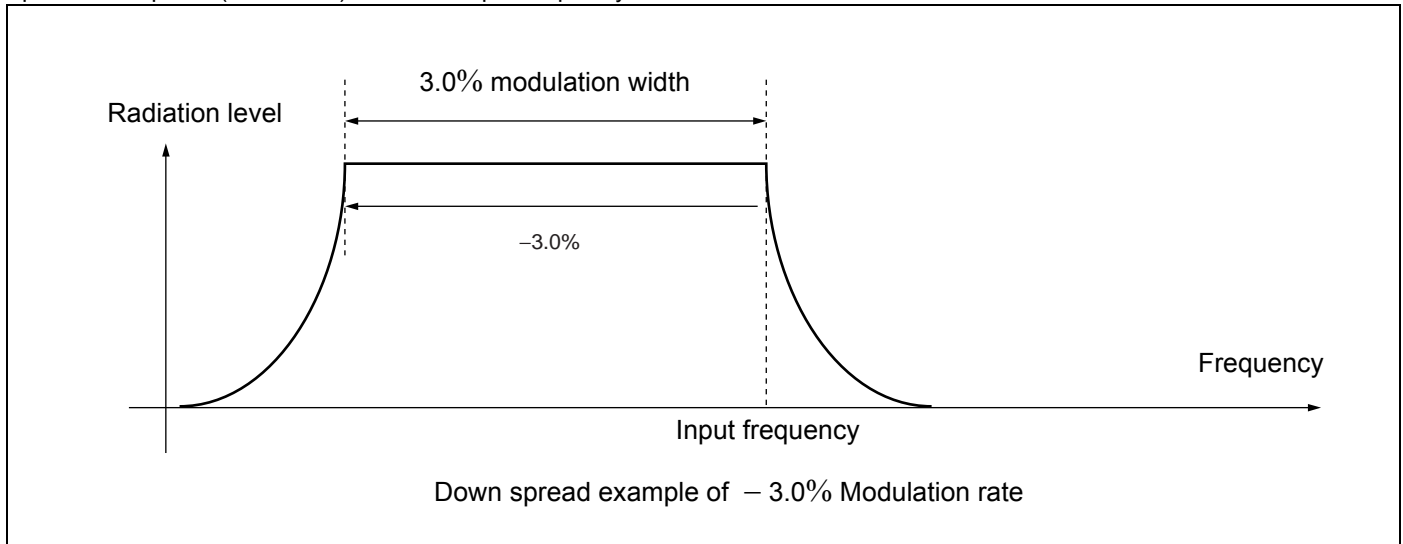

8. Absolute Maximum Ratings

Parameter	Symbol	Rating		Unit
		Min	Max	
Power supply voltage ^a	V_{DD}	- 0.5	+ 4.0	V
Input voltage ^a	V_i	$V_{SS} - 0.5$	$V_{DD} + 0.5$	V
Output voltage ^a	V_o	$V_{SS} - 0.5$	$V_{DD} + 0.5$	V
Storage temperature	T_{ST}	- 55	+ 125	°C
Operation junction temperature	T_J	- 40	+ 125	°C
Output current	I_o	- 14	+ 14	mA
Overshoot	V_{IOVER}	-	$V_{DD} + 1.0$ ($t_{OVER} \leq 50$ ns)	V
Undershoot	V_{IUNDER}	$V_{SS} - 1.0$ ($t_{UNDER} \leq 50$ ns)	-	V

a. The parameter is based on $V_{SS} = 0.0$ V.

WARNING: Semiconductor devices can be permanently damaged by application of stress (voltage, current, temperature, etc.) in excess of absolute maximum ratings. Do not exceed these ratings.

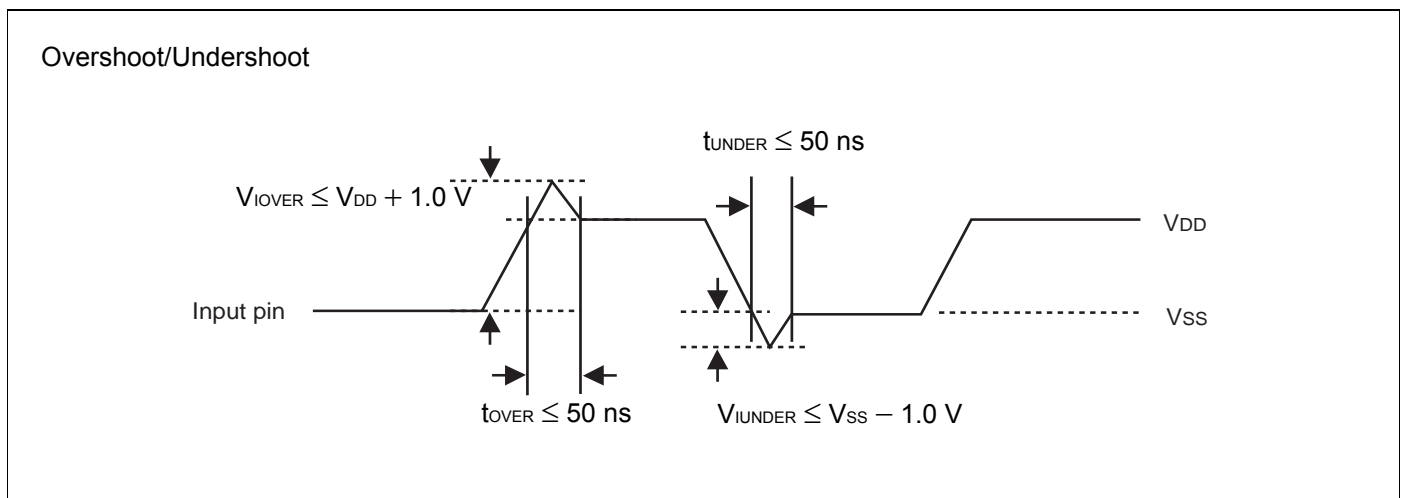

9. Recommended Operating Conditions

 (V_{SS} = 0.0 V)

Parameter	Symbol	Pin	Conditions	Value			Unit
				Min	Typ	Max	
Power supply voltage	V _{DD}	V _{DD}	—	3.0	3.3	3.6	V
“H” level input voltage	V _{IH}	SEL, FREQ/FREQ0, XENS/FREQ1	—	V _{DD} x 0.8	—	V _{DD} + 0.3	V
		XIN	16.6 MHz to 100 MHz	V _{DD} x 0.8	—	V _{DD} + 0.3	V
			100 MHz to 134 MHz	V _{DD} x 0.9	—	V _{DD} + 0.3	V
“L” level input voltage	V _{IL}	SEL, FREQ/FREQ0, XENS/FREQ1	—	V _{SS}	—	V _{DD} x 0.2	V
		XIN	16.6 MHz to 100 MHz	V _{SS}	—	V _{DD} x 0.2	V
			100 MHz to 134 MHz	V _{SS}	—	V _{DD} x 0.1	V
Input clock duty cycle	t _{DCI}	XIN	16.6 MHz to 100 MHz	40	50	60	%
			100 MHz to 134 MHz	45	50	55	
Input clock slew rate	SR _{IN}	XIN	Input frequency 40 MHz to 100 MHz	0.0475 x f _{in} — 1.75	—	—	V/ns
			Input frequency 100 MHz to 134 MHz	3	—	—	
Operating temperature	T _a	—	—	−40	—	+ 85	°C

WARNING: The recommended operating conditions are required in order to ensure the normal operation of the semiconductor device. All of the device's electrical characteristics are warranted when the device is operated within these ranges. Always use semiconductor devices within their recommended operating condition ranges. Operation outside these ranges may adversely affect reliability and could result in device failure. No warranty is made with respect to uses, operating conditions, or combinations not represented on the data sheet. Users considering application outside the listed conditions are advised to contact their representatives beforehand.

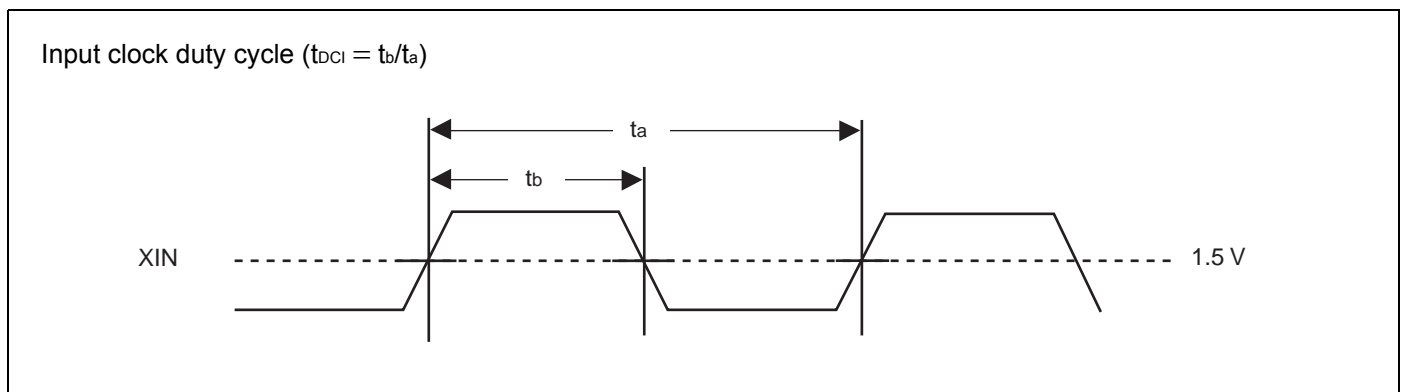

Input clock slew rate (SR_{IN})

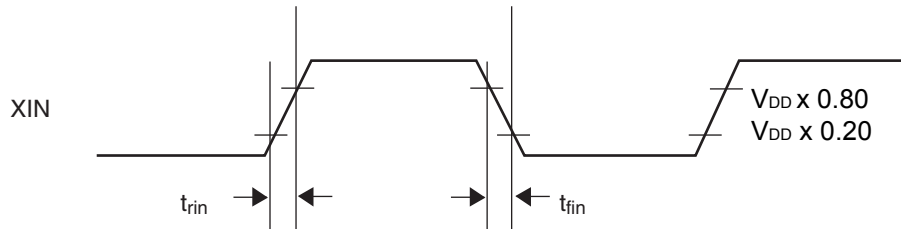

Note: $SR_{IN} = (V_{DD} \times 0.80 - V_{DD} \times 0.20) / t_{rin}$, $SR_{IN} = (V_{DD} \times 0.80 - V_{DD} \times 0.20) / t_{fin}$

10. Electrical Characteristics

10.1 DC Characteristics

($T_a = -40^{\circ}\text{C}$ to $+85^{\circ}\text{C}$, $V_{DD} = 3.3\text{ V} \pm 0.3\text{ V}$, $V_{SS} = 0.0\text{ V}$)

Parameter	Symbol	Pin	Conditions	Value			Unit
				Min	Typ	Max	
Power supply current	I_{CC}	V_{DD}	24 MHz output No load capacitance	—	5.0	7.0	mA
Output voltage	V_{OH}	CKOUT	“H” level output $I_{OH} = -4\text{ mA}$	$V_{DD} - 0.5$	—	V_{DD}	V
	V_{OL}		“L” level output $I_{OL} = 4\text{ mA}$	V_{SS}	—	0.4	V
Output impedance	Z_o	CKOUT	16.6 MHz to 134 MHz	—	45	—	Ω
Input capacitance	C_{IN}	XIN, SEL, FREQ/ FREQ0, XENS/ FREQ1	$T_a = +25^{\circ}\text{C}$ $V_{DD} = V_I = 0.0\text{ V}$ $f = 1\text{ MHz}$	—	—	16	pF
Load capacitance	C_L	CKOUT	16.6 MHz to 67 MHz	—	—	15	pF
			67 MHz to 100 MHz	—	—	10	
			100 MHz to 134 MHz	—	—	7	

10.2 AC Characteristics

 (Ta = -40°C to +85°C, V_{DD} = 3.3 V ± 0.3 V, V_{SS} = 0.0 V)

Parameter	Symbol	Pin	Conditions	Value			Unit
				Min	Typ	Max	
Oscillation frequency	f _x	XIN, XOUT	Fundamental oscillation	16.6	—	40	MHz
			3rd over tone	40	—	48	
Input frequency	f _{in}	XIN	MB88152A-100/110	16.6	—	134	MHz
			MB88152A-101/111	16.6	—	67	
			MB88152A-102/112	40	—	134	
Output frequency	f _{OUT}	CKOUT	MB88152A-100/110	16.6	—	134	MHz
			MB88152A-101/111	16.6	—	67	
			MB88152A-102/112	40	—	134	
Output slew rate	SR	CKOUT	0.4 V to 2.4 V Load capacitance 15 pF	0.4	—	4.0	V/ns
Output clock duty cycle	t _{DCC}	CKOUT	1.5 V	40	—	60	%
Modulation frequency (Number of input clocks per modulation)	f _{MOD} (n _{MOD})	CKOUT	MB88152A-100/110 FREQ[1 : 0] = (00)	f _{in} /2640 (2640)	f _{in} /2280 (2280)	f _{in} /1920 (1920)	kHz (clks)
			MB88152A-100/110 FREQ[1 : 0] = (01)	f _{in} /4400 (4400)	f _{in} /3800 (3800)	f _{in} /3200 (3200)	
			MB88152A-100/110 FREQ[1 : 0] = (10)	f _{in} /5280 (5280)	f _{in} /4560 (4560)	f _{in} /3840 (3840)	
			MB88152A-100/110 FREQ[1 : 0] = (11)	f _{in} /8800 (8800)	f _{in} /7600 (7600)	f _{in} /6400 (6400)	
			MB88152A-101/111 FREQ = 0	f _{in} /2640 (2640)	f _{in} /2280 (2280)	f _{in} /1920 (1920)	
			MB88152A-101/111 FREQ = 1	f _{in} /4400 (4400)	f _{in} /3800 (3800)	f _{in} /3200 (3200)	
			MB88152A-102/112 FREQ = 0	f _{in} /5280 (5280)	f _{in} /4560 (4560)	f _{in} /3840 (3840)	
			MB88152A-102/112 FREQ = 1	f _{in} /8800 (8800)	f _{in} /7600 (7600)	f _{in} /6400 (6400)	
Lock-Up time	t _{LK}	CKOUT	16.6 MHz to 80 MHz	—	2	5	ms
			80 MHz to 134 MHz	—	3	8	
Cycle-cycle jitter	t _{JC}	CKOUT	No load capacitance, Ta = +25°C, V _{DD} = 3.3 V	—	—	100	ps-rms

<Definition of modulation frequency and number of input clocks per modulation>

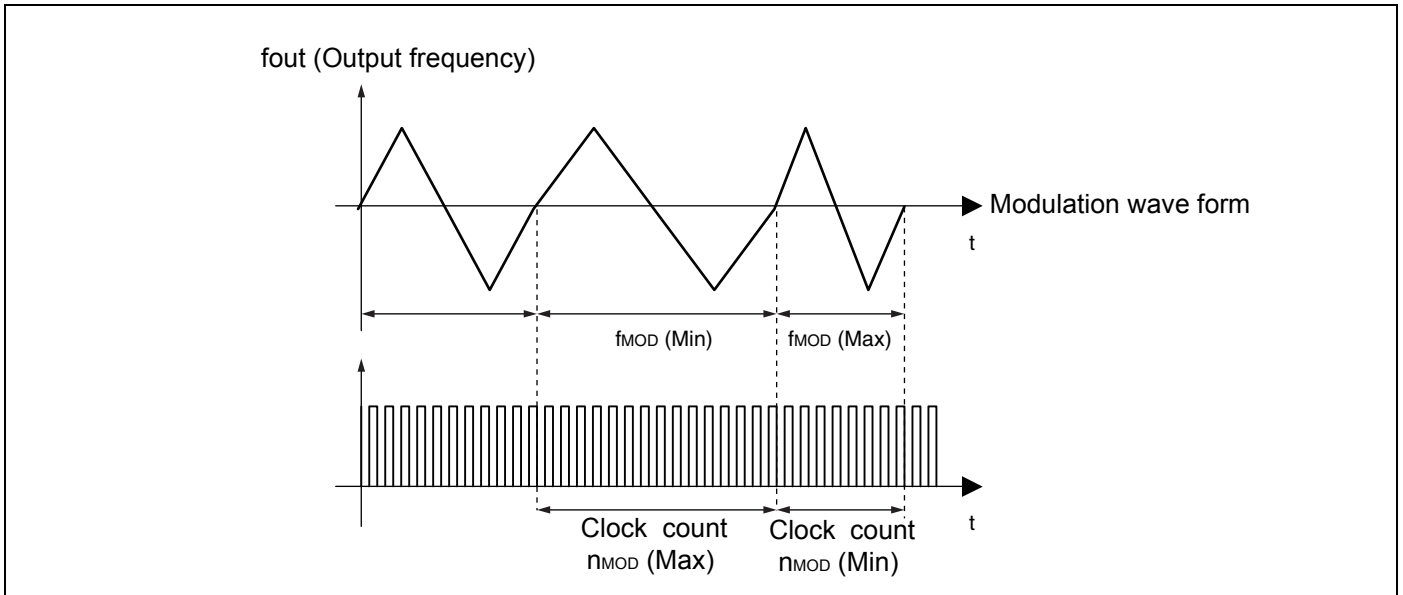

- MB88152A contains the modulation period to realize the efficient EMI reduction.
- The modulation period f_{MOD} depends on the input frequency and changes between $f_{MOD} (Min)$ and $f_{MOD} (Max)$.
- Furthermore, the average value of f_{MOD} equals the typical value of the electrical characteristics.

11. Output Clock Duty Cycle ($t_{DCC} = t_b/t_a$)

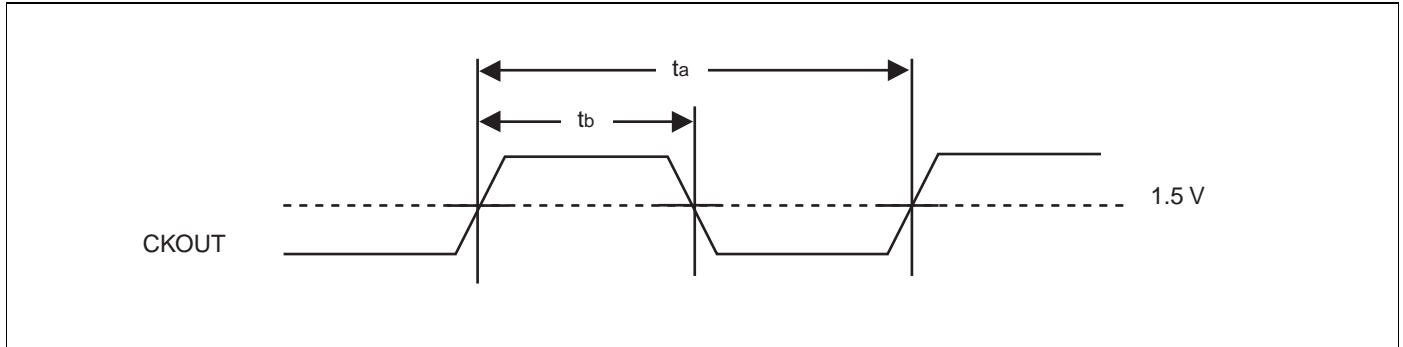

12. Input Frequency ($f_{in} = 1/t_{in}$)

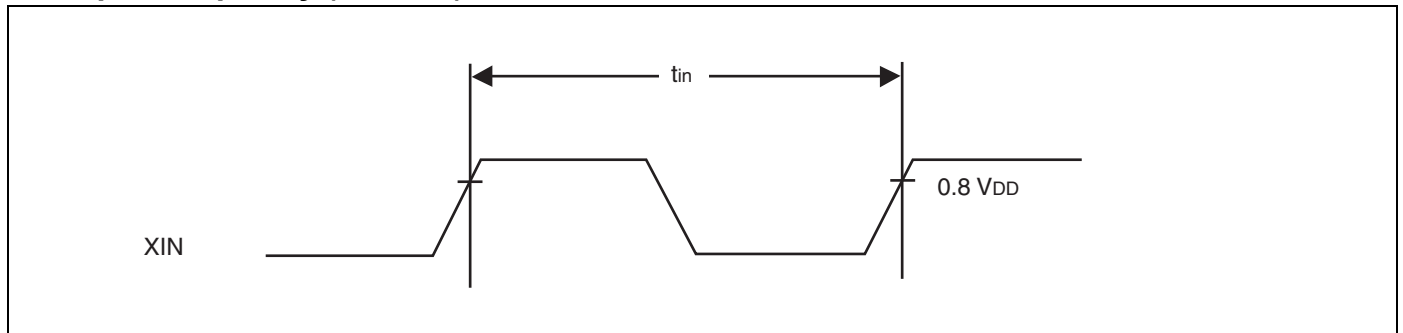

13. Output Slew Rate (SR)

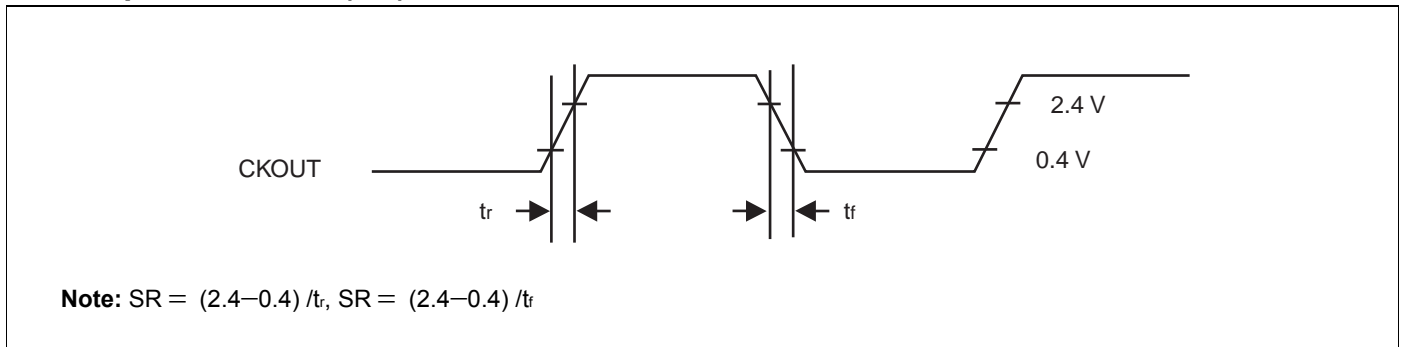

14. Cycle-cycle Jitter ($t_{JC} = |t_n - t_{n+1}|$)

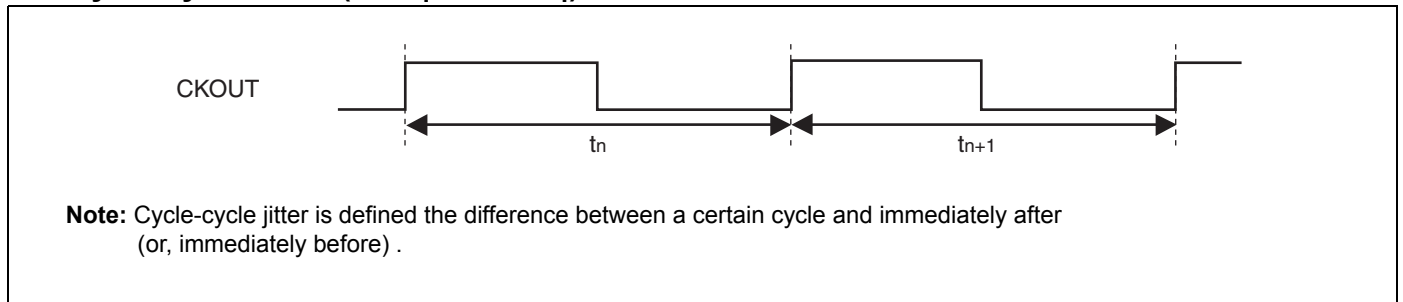

15. Modulation Waveform

±1.5% modulation rate, Example of center spread

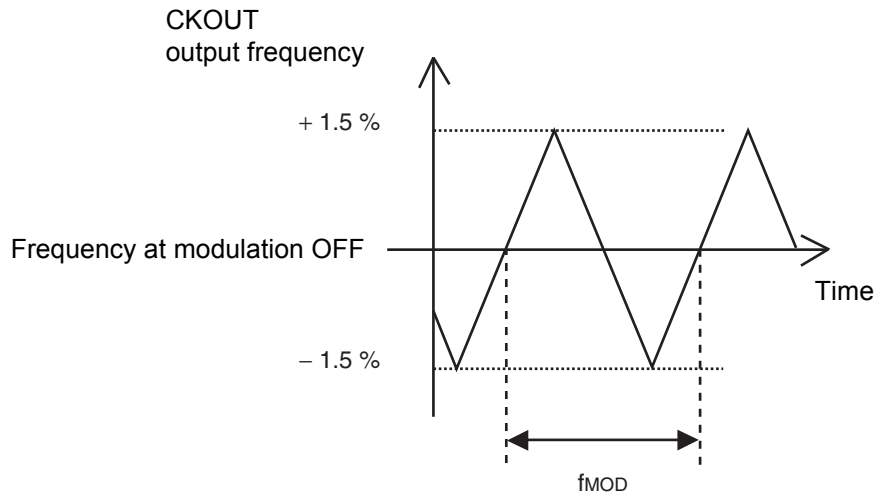

-1.0% modulation rate, Example of down spread

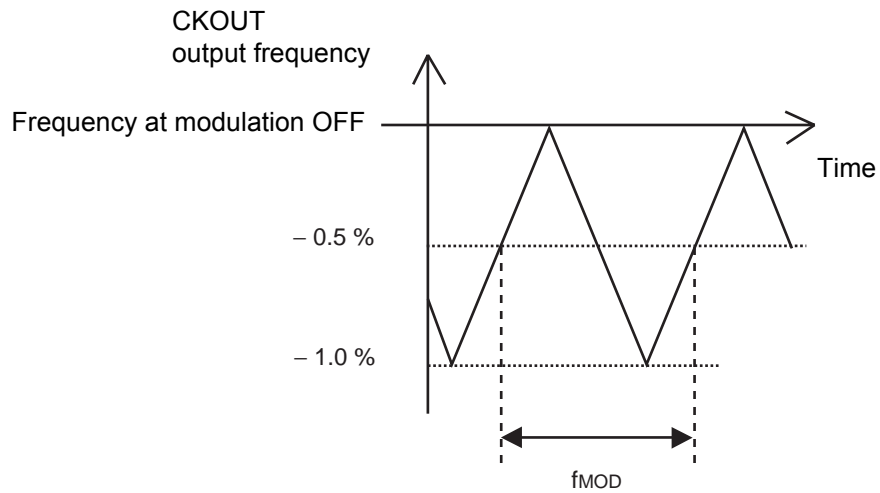

16. Lock-up Time

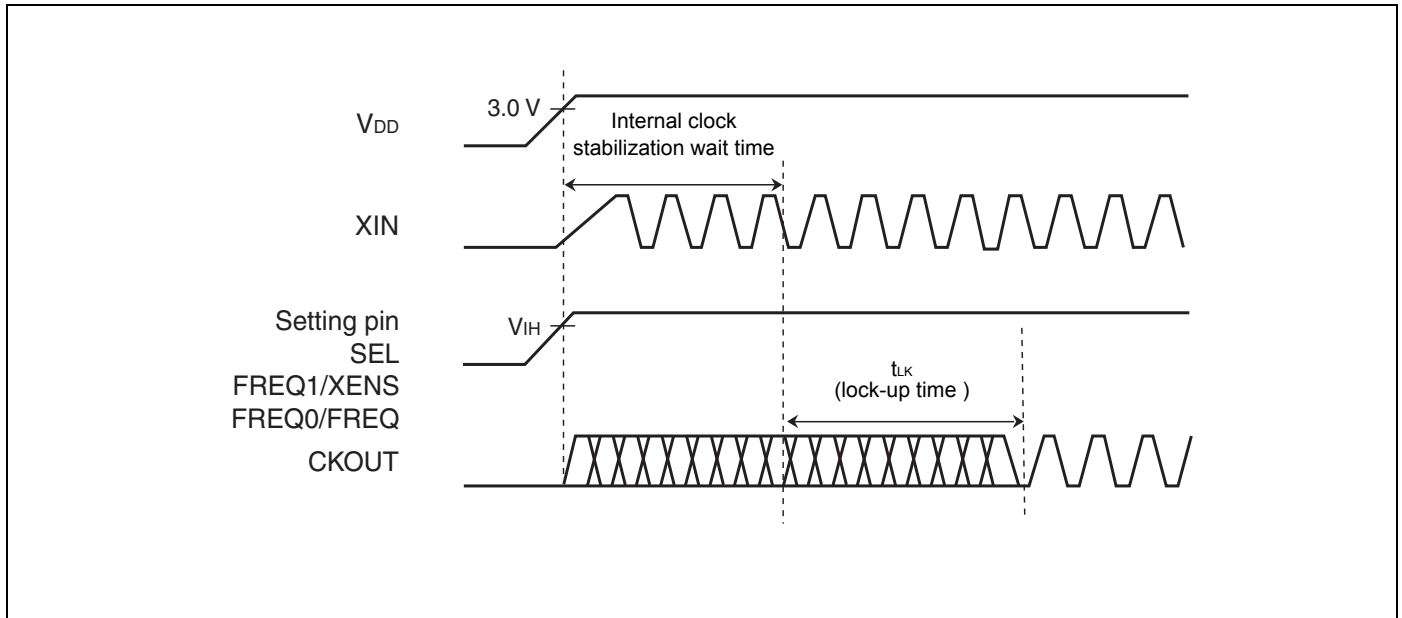

If the setting pin is fixed at the “H” or “L” level, the maximum time after the power is turned on until the set clock signal is output from CKOUT pin is (the stabilization wait time of input clock to XIN pin) + (the lock-up time “t_{LK}”). For the input clock stabilization time, check the characteristics of the resonator or oscillator used.

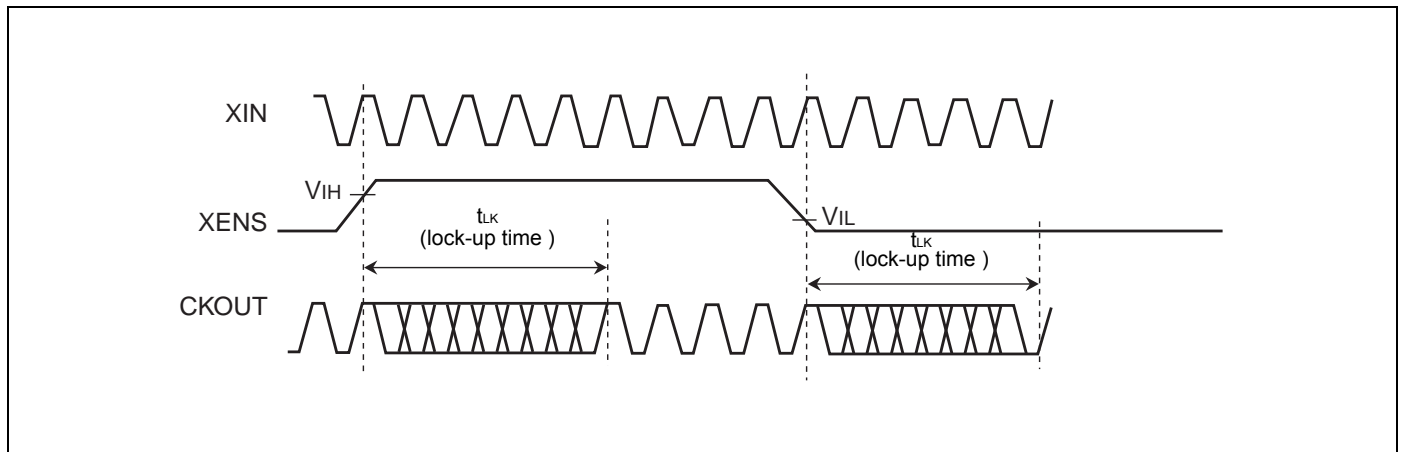

For modulation enable control using the XENS pin during normal operation, the set clock signal is output from CKOUT pin at most the lock-up time (t_{LK}) after the level at the XENS pin is determined.

Note: When the pin setting is changed, the CKOUT pin output clock stabilization time is required. Until the output clock signal becomes stable, the output frequency, output clock duty cycle, modulation period, and cycle-cycle jitter cannot be guaranteed. It is therefore advisable to perform processing such as cancelling a reset of the device at the succeeding stage after the lock-up time.

17. Oscillation Circuit

The left side of figures below shows the connection example about general resonator. The oscillation circuit has the built-in feedback resistance (R_f). The value of capacity (C_1 and C_2) is required adjusting to the most suitable value of an individual resonator. The right side of figures below shows the example of connecting for the 3rd over-tone resonator. The value of capacity (C_1 , C_2 and C_3) and inductance (L_1) is needed adjusting to the most suitable value of an individual resonator. The most suitable value is different by individual resonator. Please refer to the resonator manufacturer which you use for the most suitable value. When an external clock is used (the resonator is not used), input the clock to XIN pin and do not connect anything with XOUT pin.

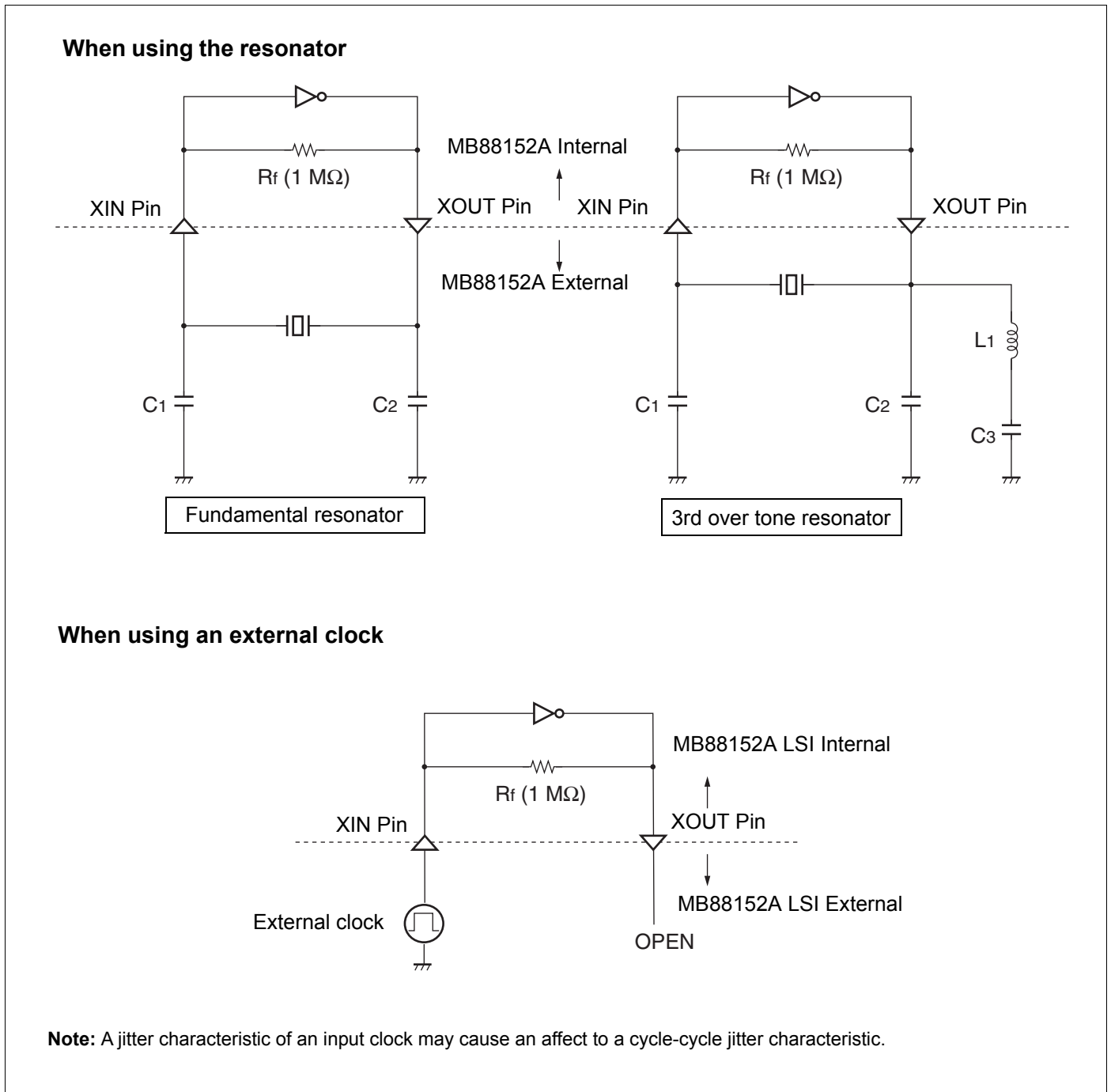

18. Interconnection Circuit Example

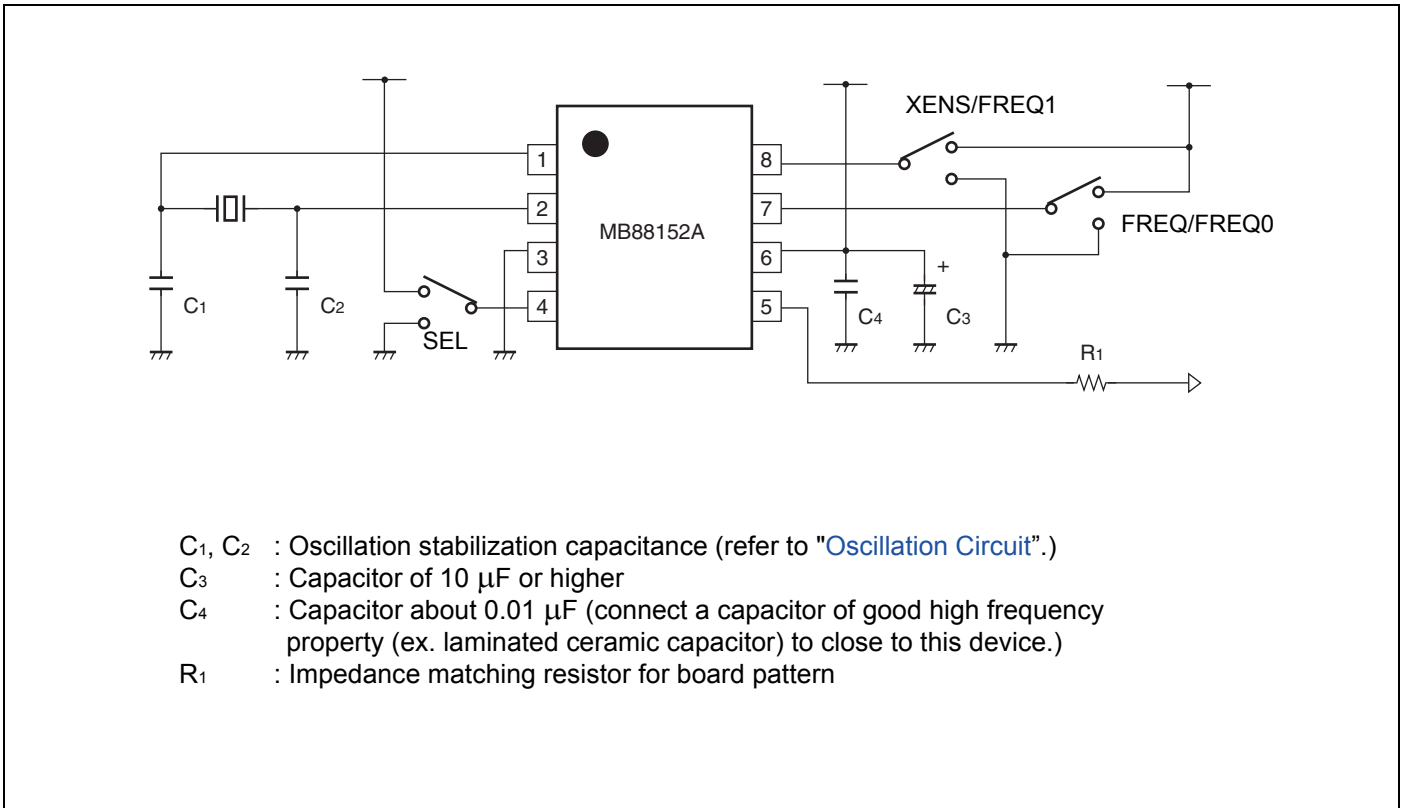

19. Example Characteristics

The condition of the examples of the characteristics is shown as follows : Input frequency = 20 MHz (Output frequency = 20 MHz : Use for MB88152A-111)

Power-supply voltage = 3.3 V, None load capacity, Modulation rate = $\pm 1.5\%$ (center spread) .

Spectrum analyzer HP4396B is connected with CKOUT. The result of the measurement with, RBW = 1 kHz (ATT use for -6 dB) .

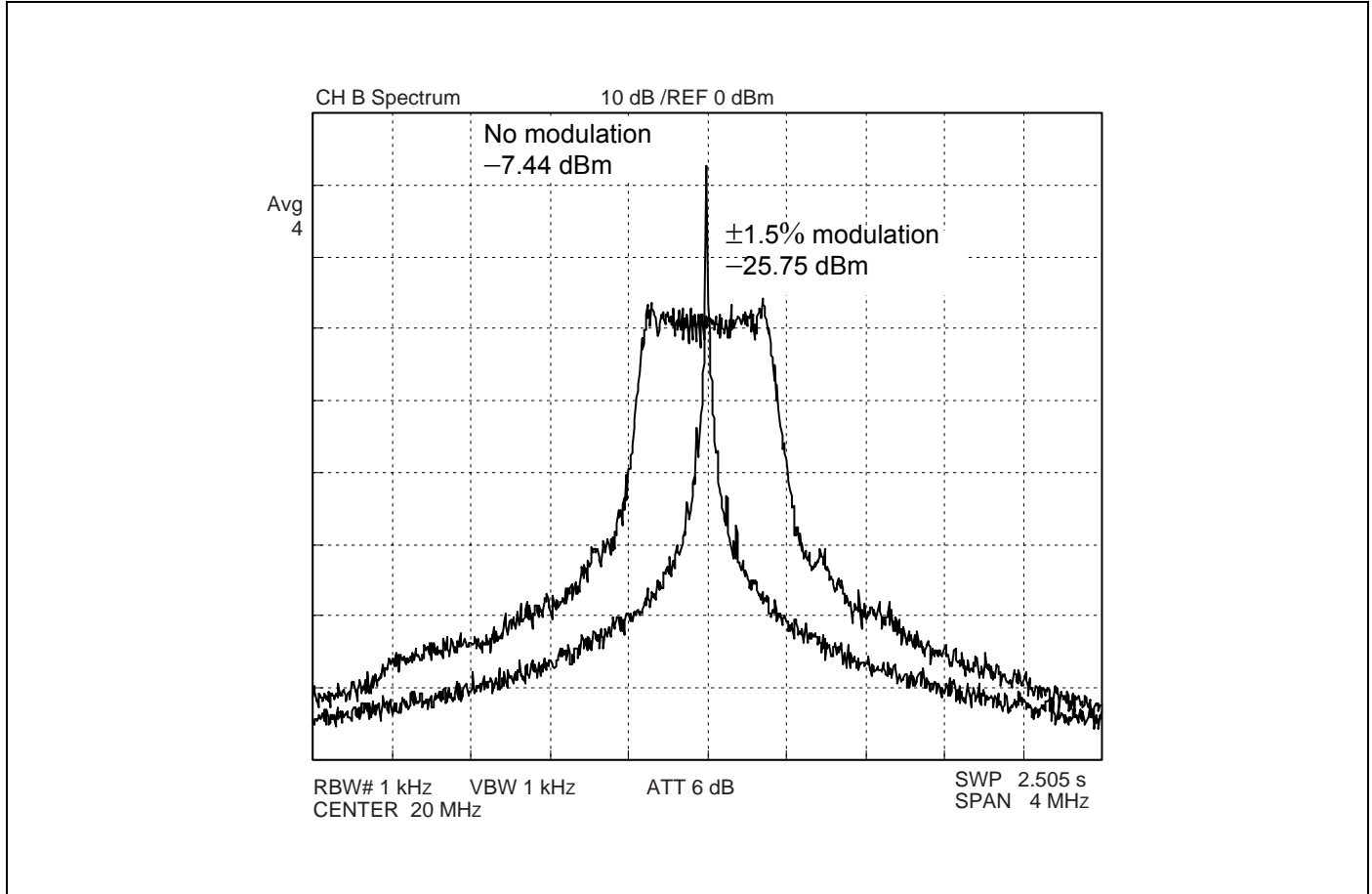

20. Ordering Information

Part number	Input/Output Frequency	Modulation type	Modulation enable pin	Package	Remarks
MB88152APNF-G-100-JNE1	16.6 MHz to 134 MHz	Down spread	No	8-pin plastic SOP (FPT-8P-M02)	
MB88152APNF-G-101-JNE1	16.6 MHz to 67 MHz	Down spread	Yes		
MB88152APNF-G-102-JNE1	40 MHz to 134 MHz	Down spread	Yes		
MB88152APNF-G-110-JNE1	16.6 MHz to 134 MHz	Center spread	No		
MB88152APNF-G-111-JNE1	16.6 MHz to 67 MHz	Center spread	Yes		
MB88152APNF-G-112-JNE1	40 MHz to 134 MHz	Center spread	Yes		
MB88152APNF-G-100-JNEFE1	16.6 MHz to 134 MHz	Down spread	No	8-pin plastic SOP (FPT-8P-M02)	Emboss tapping (EF type)
MB88152APNF-G-101-JNEFE1	16.6 MHz to 67 MHz	Down spread	Yes		
MB88152APNF-G-102-JNEFE1	40 MHz to 134 MHz	Down spread	Yes		
MB88152APNF-G-110-JNEFE1	16.6 MHz to 134 MHz	Center spread	No		
MB88152APNF-G-111-JNEFE1	16.6 MHz to 67 MHz	Center spread	Yes		
MB88152APNF-G-112-JNEFE1	40 MHz to 134 MHz	Center spread	Yes		
MB88152APNF-G-100-JNERE1	16.6 MHz to 134 MHz	Down spread	No	8-pin plastic SOP (FPT-8P-M02)	Emboss tapping (ER type)
MB88152APNF-G-101-JNERE1	16.6 MHz to 67 MHz	Down spread	Yes		
MB88152APNF-G-102-JNERE1	40 MHz to 134 MHz	Down spread	Yes		
MB88152APNF-G-110-JNERE1	16.6 MHz to 134 MHz	Center spread	No		
MB88152APNF-G-111-JNERE1	16.6 MHz to 67 MHz	Center spread	Yes		
MB88152APNF-G-112-JNERE1	40 MHz to 134 MHz	Center spread	Yes		

21. Package Dimension

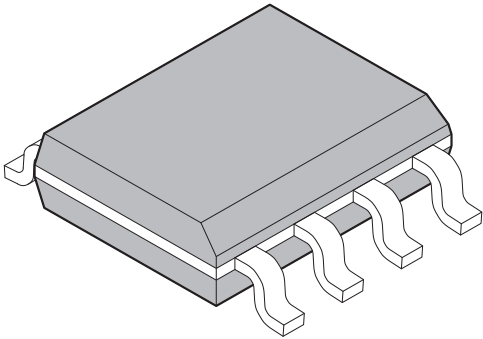
<p>8-pin plastic SOP</p>  <p>(FPT-8P-M02)</p>	Lead pitch	1.27 mm
	Package width × package length	3.9 × 5.05 mm
	Lead shape	Gullwing
	Sealing method	Plastic mold
	Mounting height	1.75 mm MAX
	Weight	0.06 g

8-pin plastic SOP (FPT-8P-M02)

Note 1) *1 : These dimensions include resin protrusion.
 Note 2) *2 : These dimensions do not include resin protrusion.
 Note 3) Pins width and pins thickness include plating thickness.
 Note 4) Pins width do not include tie bar cutting remainder.

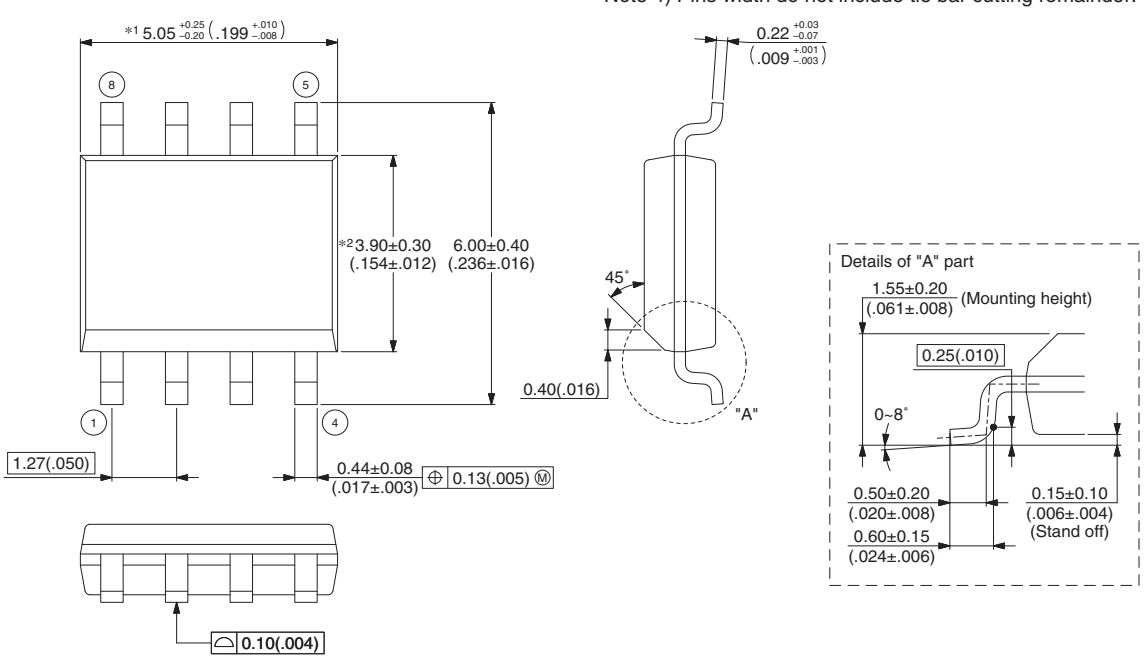

Dimensions in mm (inches).
 Note: The values in parentheses are reference values.

©2002-2008 FUJITSU MICROELECTRONICS LIMITED F08004S-c-4-8

Document History

Document Title: MB88152A Spread Spectrum Clock Generator				
Document Number: 002-08308				
Revision	ECN	Orig. of Change	Submission Date	Description of Change
**	–	TAOA	06/29/2009	Initial release.
*A	5560671	TAOA	12/28/2016	Migrated Spansion datasheet "DS04-29125-3E" into Cypress Template.

Sales, Solutions, and Legal Information

Worldwide Sales and Design Support

Cypress maintains a worldwide network of offices, solution centers, manufacturer’s representatives, and distributors. To find the office closest to you, visit us at [Cypress Locations](#).

Products

ARM® Cortex® Microcontrollers	cypress.com/arm
Automotive	cypress.com/automotive
Clocks & Buffers	cypress.com/clocks
Interface	cypress.com/interface
Internet of Things	cypress.com/iot
Lighting & Power Control	cypress.com/powerpsoc
Memory	cypress.com/memory
PSoC	cypress.com/psoc
Touch Sensing	cypress.com/touch
USB Controllers	cypress.com/usb
Wireless/RF	cypress.com/wireless

PSoC® Solutions

[PSoC 1](#) | [PSoC 3](#) | [PSoC 4](#) | [PSoC 5LP](#)

Cypress Developer Community

[Forums](#) | [WICED IoT Forums](#) | [Projects](#) | [Video](#) | [Blogs](#) | [Training](#) | [Components](#)

Technical Support

cypress.com/support

© Cypress Semiconductor Corporation, 2006-2016. This document is the property of Cypress Semiconductor Corporation and its subsidiaries, including Spansion LLC (“Cypress”). This document, including any software or firmware included or referenced in this document (“Software”), is owned by Cypress under the intellectual property laws and treaties of the United States and other countries worldwide. Cypress reserves all rights under such laws and treaties and does not, except as specifically stated in this paragraph, grant any license under its patents, copyrights, trademarks, or other intellectual property rights. If the Software is not accompanied by a license agreement and you do not otherwise have a written agreement with Cypress governing the use of the Software, then Cypress hereby grants you a personal, non-exclusive, nontransferable license (without the right to sublicense) (1) under its copyright rights in the Software (a) for Software provided in source code form, to modify and reproduce the Software solely for use with Cypress hardware products, only internally within your organization, and (b) to distribute the Software in binary code form externally to end users (either directly or indirectly through resellers and distributors), solely for use on Cypress hardware product units, and (2) under those claims of Cypress’s patents that are infringed by the Software (as provided by Cypress, unmodified) to make, use, distribute, and import the Software solely for use with Cypress hardware products. Any other use, reproduction, modification, translation, or compilation of the Software is prohibited.

TO THE EXTENT PERMITTED BY APPLICABLE LAW, CYPRESS MAKES NO WARRANTY OF ANY KIND, EXPRESS OR IMPLIED, WITH REGARD TO THIS DOCUMENT OR ANY SOFTWARE OR ACCOMPANYING HARDWARE, INCLUDING, BUT NOT LIMITED TO, THE IMPLIED WARRANTIES OF MERCHANTABILITY AND FITNESS FOR A PARTICULAR PURPOSE. To the extent permitted by applicable law, Cypress reserves the right to make changes to this document without further notice. Cypress does not assume any liability arising out of the application or use of any product or circuit described in this document. Any information provided in this document, including any sample design information or programming code, is provided only for reference purposes. It is the responsibility of the user of this document to properly design, program, and test the functionality and safety of any application made of this information and any resulting product. Cypress products are not designed, intended, or authorized for use as critical components in systems designed or intended for the operation of weapons, weapons systems, nuclear installations, life-support devices or systems, other medical devices or systems (including resuscitation equipment and surgical implants), pollution control or hazardous substances management, or other uses where the failure of the device or system could cause personal injury, death, or property damage (“Unintended Uses”). A critical component is any component of a device or system whose failure to perform can be reasonably expected to cause the failure of the device or system, or to affect its safety or effectiveness. Cypress is not liable, in whole or in part, and you shall and hereby do release Cypress from any claim, damage, or other liability arising from or related to all Unintended Uses of Cypress products. You shall indemnify and hold Cypress harmless from and against all claims, costs, damages, and other liabilities, including claims for personal injury or death, arising from or related to any Unintended Uses of Cypress products.

Cypress, the Cypress logo, Spansion, the Spansion logo, and combinations thereof, WICED, PSoC, CapSense, EZ-USB, F-RAM, and Traveo are trademarks or registered trademarks of Cypress in the United States and other countries. For a more complete list of Cypress trademarks, visit cypress.com. Other names and brands may be claimed as property of their respective owners.