

阅读申明

- 1.本站收集的数据手册和产品资料都来自互联网，版权归原作者所有。如读者和版权方有任何异议请及时告之，我们将妥善解决。
- 2.本站提供的中文数据手册是英文数据手册的中文翻译，其目的是协助用户阅读，该译文无法自动跟随原稿更新，同时也可能存在翻译上的不当。建议读者以英文原稿为参考以便获得更精准的信息。
- 3.本站提供的产品资料，来自厂商的技术支持或者使用者的心得体会等，其内容可能存在描述上的差异，建议读者做出适当判断。
- 4.如需与我们联系，请发邮件到marketing@iczoom.com，主题请标有“数据手册”字样。

Read Statement

1. The datasheets and other product information on the site are all from network reference or other public materials, and the copyright belongs to the original author and original published source. If readers and copyright owners have any objections, please contact us and we will deal with it in a timely manner.
2. The Chinese datasheets provided on the website is a Chinese translation of the English datasheets. Its purpose is for reader's learning exchange only and do not involve commercial purposes. The translation cannot be automatically updated with the original manuscript, and there may also be improper translations. Readers are advised to use the English manuscript as a reference for more accurate information.
3. All product information provided on the website refer to solutions from manufacturers' technical support or users the contents may have differences in description, and readers are advised to take the original article as the standard.
4. If you have any questions, please contact us at marketing@iczoom.com and mark the subject with "Datasheets" .

Description

The Cypress Semiconductor MB15F73UL is a serial input Phase Locked Loop (PLL) frequency synthesizer with a 2250 MHz and a 600-MHz prescalers. A 64/65 or a 128/129 for the 2250-MHz prescaler, and a 8/9 or a 16/17 for the 600 MHz prescaler can be selected for the prescaler that enables pulse swallow operation.

The BiCMOS process is used, as a result a supply current is typically 3.2 mA at 2.7 V. The supply voltage range is from 2.4 V to 3.6 V. A refined charge pump supplies well-balanced output current with 1.5 mA and 6 mA selectable by serial date. The data format is the same as the previous one MB15F03SL and MB15F73SP. Fast locking is achieved for adopting the new circuit.

Features

- High frequency operation
 - RF synthesizer: 2250 MHz Max
 - IF synthesizer: 600 MHz Max
- Low power supply voltage: $V_{CC} = 2.4 \text{ V to } 3.6 \text{ V}$
- Ultra low power supply current: $I_{CC} = 3.2 \text{ mA Typ}$ ($V_{CC} = V_p = 2.7 \text{ V}$, $SW_{IF} = SW_{RF} = 0$, $T_a = +25 \text{ }^\circ\text{C}$, in IF, RF locking state)
- Direct power saving function: Power supply current in power saving mode
 - Typ $0.1 \text{ } \mu\text{A}$ ($V_{CC} = V_p = 2.7 \text{ V}$, $T_a = +25 \text{ }^\circ\text{C}$)
 - Max $10 \text{ } \mu\text{A}$ ($V_{CC} = V_p = 2.7 \text{ V}$)
- Software selectable charge pump current : 1.5 mA/6.0 mA Typ
- Dual modulus prescaler: 2250-MHz prescaler (64/65 or 128/129) /600 MHz prescaler (8/9 or 16/17)
 - 23-bit shift register
 - Serial input binary 14-bit programmable reference divider: $R = 3 \text{ to } 16,383$
 - Serial input programmable divider consisting of:
 - Binary 7-bit swallow counter: 0 to 127
 - Binary 11-bit programmable counter: 3 to 2,047
 - Built-in high-speed tuning, low-noise phase comparator, current-switching type constant current circuit
 - On-chip phase control for phase comparator
 - On-chip phase comparator for fast lock and low noise
 - Built-in digital locking detector circuit to detect PLL locking and unlocking.
 - Operating temperature: $T_a = -40 \text{ }^\circ\text{C to } +85 \text{ }^\circ\text{C}$

Block Diagram

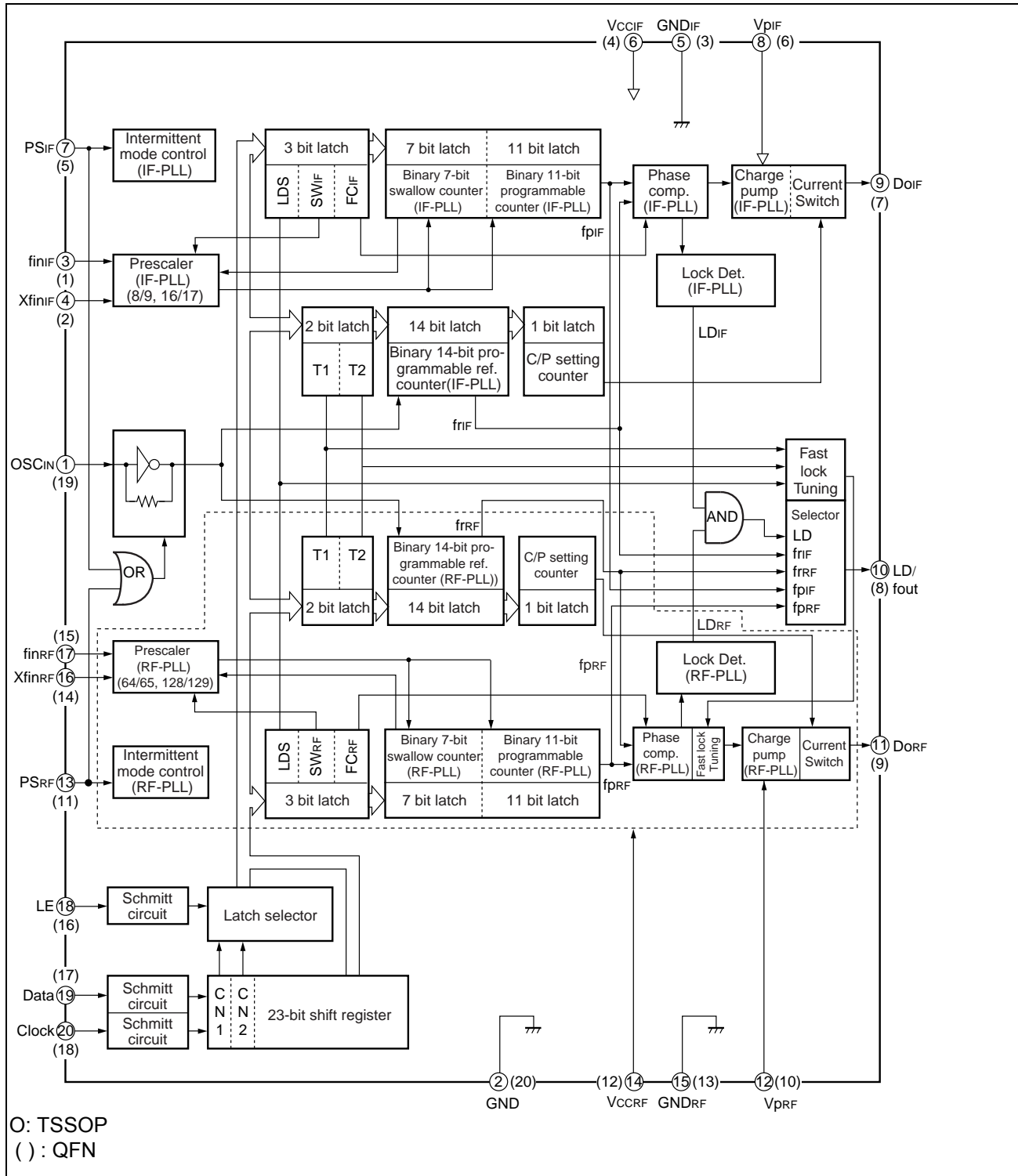

Contents

Pin Assignments	4	RF-PLL Do output current	18
Pin Description	5	IF-PLL Do output current	19
Absolute Maximum Ratings	6	fin input impedance	20
Recommended Operating Conditions	6	OSCIN input impedance	21
Electrical Characteristics	7	Reference Information (for Lock-up Time, Phase Noise, and	
Functional Description	9	Reference Leakage)	22
Pulse swallow function	9	Application Example	24
Serial Data Input	9	Usage Precautions	25
Shift Register Configuration	9	Ordering Information	25
Data setting	10	Package Dimensions	26
Power Saving Mode (Intermittent Mode		Document History Page	28
Control Circuit)	12	Sales, Solutions, and Legal Information	29
Serial Data Input Timing	13	Worldwide Sales and Design Support	29
Phase Comparator Output Waveform	14	Products	29
LD Output Logic	14	PSoC® Solutions	29
Test Circuit (for Measuring Input Sensitivity		Cypress Developer Community	29
fin/OSCIN)	15	Technical Support	29
Typical Characteristics	16		
Fin Input Sensitivity	16		
OSCIN input sensitivity	17		

Pin Assignments

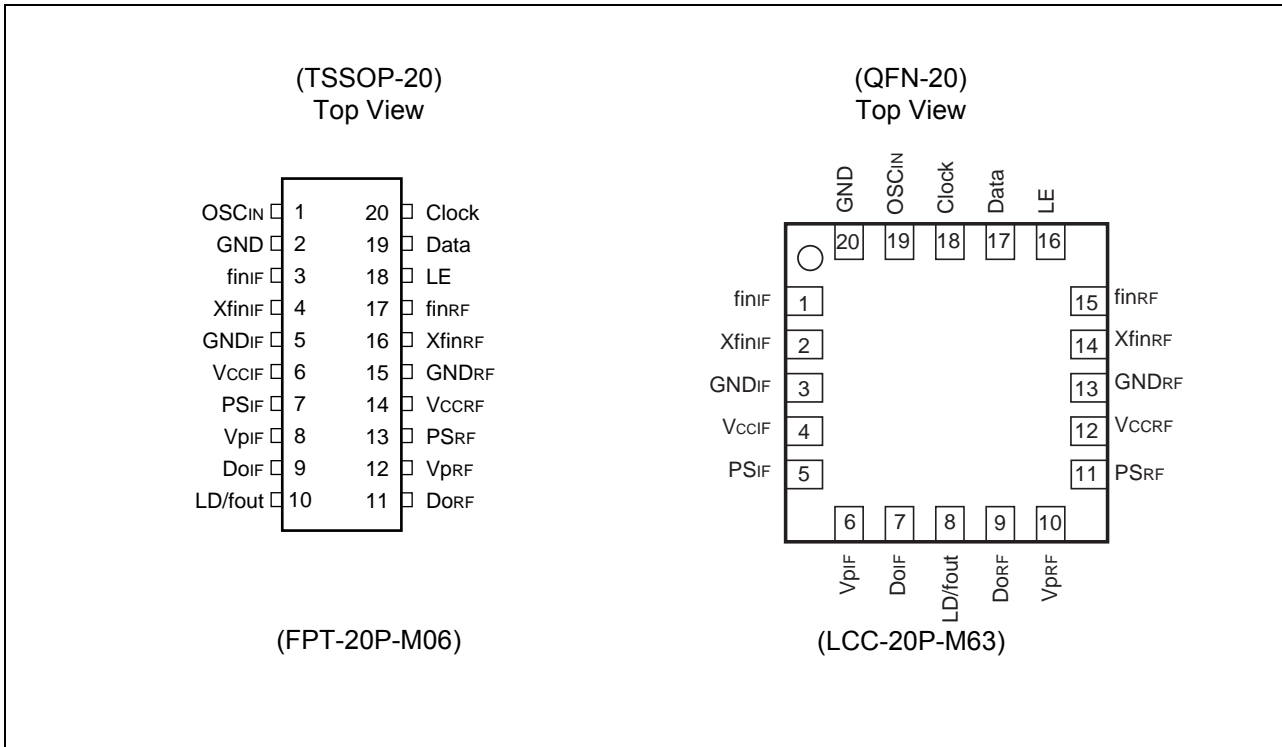

Pin Description

Pin no.		Pin name	I/O	Descriptions
TSSOP	QFN			
1	19	OSC _{IN}	I	The programmable reference divider input pin. TCXO should be connected with an AC coupling capacitor.
2	20	GND	–	Ground pin for OSC input buffer and the shift register circuit.
3	1	fin _{IF}	I	Prescaler input pin for the IF-PLL. Connection to an external VCO should be via AC coupling.
4	2	Xfin _{IF}	I	Prescaler complimentary input for the IF-PLL section. This pin should be grounded via a capacitor.
5	3	GND _{IF}	–	Ground pin for the IF-PLL section.
6	4	V _{CCIF}	–	Power supply voltage input pin for the IF-PLL section (except for the charge pump circuit), the shift register, and the oscillator input buffer.
7	5	PS _{IF}	I	Power saving mode control for the IF-PLL section. This pin must be set at “L” when the power supply is started up. (Open is prohibited.) PS _{IF} = “H”; Normal mode / PS _{IF} = “L”; Power saving mode
8	6	V _{pIF}	–	Power supply voltage input pin for the IF-PLL charge pump.
9	7	DO _{IF}	O	Charge pump output for the IF-PLL section.
10	8	LD/fout	O	Lock detect signal output (LD) /phase comparator monitoring output (fout) pin. The output signal is selected by LDS bit in the serial data. LDS bit = “H”; outputs fout signal / LDS bit = “L”; outputs LD signal
11	9	DO _{RF}	O	Charge pump output for the RF-PLL section.
12	10	V _{pRF}	–	Power supply voltage input pin for the RF-PLL charge pump.
13	11	PS _{RF}	I	Power saving mode control for the RF-PLL section. This pin must be set at “L” when the power supply is started up. (Open is prohibited.) PS _{RF} = “H”; Normal mode / PS _{RF} = “L”; Power saving mode
14	12	V _{CCRF}	–	Power supply voltage input pin for the RF-PLL section (except for the charge pump circuit)
15	13	GND _{RF}	–	Ground pin for the RF-PLL section
16	14	Xfin _{RF}	I	Prescaler complimentary input pin for the RF-PLL section. This pin should be grounded via a capacitor.
17	15	fin _{RF}	I	Prescaler input pin for the RF-PLL. Connection to an external VCO should be via AC coupling.
18	16	LE	I	Load enable signal input pin (with the schmitt trigger circuit) When LE is set “H”, data in the shift register is transferred to the corresponding latch according to the control bit in the serial data.
19	17	Data	I	Serial data input pin (with the schmitt trigger circuit) Data is transferred to the corresponding latch (IF-ref. counter, IF-prog. counter, RF-ref. counter, RF-prog. counter) according to the control bit in the serial data.
20	18	Clock	I	Clock input pin for the 23-bit shift register (with the schmitt trigger circuit) One bit of data is shifted into the shift register on a rising edge of the clock.

Absolute Maximum Ratings

Parameter	Symbol	Rating		Unit	
		Min	Max		
Power supply voltage	V_{CC}	-0.5	+4.0	V	
	V_p	V_{CC}	4.0	V	
Input voltage	V_I	-0.5	$V_{CC}+0.5$	V	
Output voltage	LD/fout	V_O	GND	V_{CC}	V
	DOIF, DORF	V_{DO}	GND	V_p	V
Storage temperature	Tstg	-55	+125	°C	

WARNING: Semiconductor devices can be permanently damaged by application of stress (voltage, current, temperature, etc.) in excess of absolute maximum ratings. Do not exceed these ratings.

Recommended Operating Conditions

Parameter	Symbol	Value			Unit	Remarks
		Min	Typ	Max		
Power supply voltage	V_{CC}	2.4	2.7	3.6	V	$V_{CCRF} = V_{CCIF}$
	V_p	V_{CC}	2.7	3.6	V	
Input voltage	V_I	GND	-	V_{CC}	V	
Operating temperature	T_a	-40	-	+85	°C	

Note: ■ V_{CCRF} , V_{pRF} , V_{CCIF} and V_{pIF} must supply equal voltage.

Even if either RF-PLL or IF-PLL is not used, power must be supplied to V_{CCRF} , V_{pRF} , V_{CCIF} and V_{pIF} to keep them equal. It is recommended that the non-use PLL is controlled by power saving function.

■ Although this device contains an anti-static element to prevent electrostatic breakdown and the circuitry has been improved in electrostatic protection, observe the following precautions when handling the device.

- When storing and transporting the device, put it in a conductive case.
- Before handling the device, confirm the (jigs and) tools to be used have been uncharged (grounded) as well as yourself. Use a conductive sheet on working bench.
- Before fitting the device into or removing it from the socket, turn the power supply off.
- When handling (such as transporting) the device mounted board, protect the leads with a conductive sheet.

WARNING: The recommended operating conditions are required in order to ensure the normal operation of the semiconductor device. All of the device's electrical characteristics are warranted when the device is operated within these ranges.

Always use semiconductor devices within their recommended operating condition ranges.

Operation outside these ranges may adversely affect reliability and could result in device failure.

No warranty is made with respect to uses, operating conditions, or combinations not represented on the datasheet. Users considering application outside the listed conditions are advised to contact their representatives beforehand.

Electrical Characteristics

($V_{CC} = 2.4\text{ V to }3.6\text{ V}$, $T_a = -40\text{ }^\circ\text{C to }+85\text{ }^\circ\text{C}$)

Parameter	Symbol	Condition	Value			Unit	
			Min	Typ	Max		
Power supply current	$I_{CCIF}^{[1]}$	$f_{inIF} = 480\text{ MHz}$ $V_{CCIF} = V_{pIF} = 2.7\text{ V}$	0.8	1.2	1.7	mA	
	$I_{CCRF}^{[1]}$	$f_{inRF} = 2000\text{ MHz}$ $V_{CCRF} = V_{pRF} = 2.7\text{ V}$	1.3	2.0	2.8	mA	
Power saving current	I_{PSIF}	$PS_{IF} = PS_{RF} = \text{"L"}$	–	0.1 ^[2]	10	μA	
	I_{PSRF}	$PS_{IF} = PS_{RF} = \text{"L"}$	–	0.1 ^[2]	10	μA	
Operating frequency	$f_{inIF}^{[3]}$	f_{inIF}	IF PLL	50	–	600	MHz
	$f_{inRF}^{[3]}$	f_{inRF}	RF PLL	200	–	2250	MHz
	OSC_{IN}	f_{OSC}	–	3	–	40	MHz
Input sensitivity	f_{inIF}	P_{finIF}	IF PLL, 50 Ω system	–15	–	+2	dBm
	f_{inRF}	P_{finRF}	RF PLL, 50 Ω system	–15	–	+2	dBm
	OSC_{IN}	V_{OSC}	–	0.5	–	V_{CC}	V_{P-P}
"H" level input voltage	Data, LE, Clock	V_{IH}	Schmitt trigger input	$0.7 V_{CC} + 0.4$	–	–	V
"L" level input voltage		V_{IL}	Schmitt trigger input	–	–	$0.3 V_{CC} - 0.4$	V
"H" level input voltage	PS_{IF} , PS_{RF}	V_{IH}	–	$0.7 V_{CC}$	–	–	V
"L" level input voltage		V_{IL}	–	–	–	$0.3 V_{CC}$	V
"H" level input current	Data, LE, Clock, PS_{IF} , PS_{RF}	$I_{IH}^{[4]}$	–	–1.0	–	+1.0	μA
"L" level input current		$I_{IL}^{[4]}$	–	–1.0	–	+1.0	μA
"H" level input current	OSC_{IN}	I_{IH}	–	0	–	+100	μA
"L" level input current		$I_{IL}^{[4]}$	–	–100	–	0	μA
"H" level output voltage	LD/fout	V_{OH}	$V_{CC} = V_p = 2.7\text{ V}$, $I_{OH} = -1\text{ mA}$	$V_{CC} - 0.4$	–	–	V
"L" level output voltage		V_{OL}	$V_{CC} = V_p = 2.7\text{ V}$, $I_{OL} = 1\text{ mA}$	–	–	0.4	V
"H" level output voltage	DO_{IF} , DO_{RF}	V_{DOH}	$V_{CC} = V_p = 2.7\text{ V}$, $I_{DOH} = -0.5\text{ mA}$	$V_p - 0.4$	–	–	V
"L" level output voltage		V_{DOL}	$V_{CC} = V_p = 2.7\text{ V}$, $I_{DOL} = 0.5\text{ mA}$	–	–	0.4	V
High impedance cutoff current	DO_{IF} , DO_{RF}	I_{OFF}	$V_{CC} = V_p = 2.7\text{ V}$ $V_{OFF} = 0.5\text{ V to }V_p - 0.5\text{ V}$	–	–	2.5	nA
"H" level output current	LD/fout	$I_{OH}^{[4]}$	$V_{CC} = V_p = 2.7\text{ V}$	–	–	–1.0	mA
"L" level output current		I_{OL}	$V_{CC} = V_p = 2.7\text{ V}$	1.0	–	–	mA

Notes

- Conditions; $f_{osc} = 12.8\text{ MHz}$, $T_a = +25\text{ }^\circ\text{C}$, SW = "L" in locking state.
- $V_{CCIF} = V_{pIF} = V_{CCRF} = V_{pRF} = 2.7\text{ V}$, $f_{osc} = 12.8\text{ MHz}$, $T_a = +25\text{ }^\circ\text{C}$, in power saving mode $PS_{IF} = PS_{RF} = \text{GND}$, $V_{IH} = V_{CC}$, $V_{IL} = \text{GND}$ (at CLK, Data, LE).
- AC coupling. 1000 pF capacitor is connected under the condition of minimum operating frequency.
- The symbol "–" (minus) means the direction of current flow.

$(V_{CC} = 2.4 \text{ V to } 3.6 \text{ V, } T_a = -40 \text{ }^\circ\text{C to } +85 \text{ }^\circ\text{C})$

Parameter	Symbol	Condition	Value			Unit	
			Min	Typ	Max		
"H" level output current	DoIF ^[5] , DoRF	I _{DOH} ^[4] V _{CC} = V _p = 2.7 V, V _{DOH} = V _p / 2, T _a = +25 °C	CS bit = "H"	-8.2	-6.0	-4.1	mA
			CS bit = "L"	-2.2	-1.5	-0.8	mA
"L" level output current	DoIF ^[5] , DoRF	I _{DOL} V _{CC} = V _p = 2.7 V, V _{DOL} = V _p / 2, T _a = +25 °C	CS bit = "H"	4.1	6.0	8.2	mA
			CS bit = "L"	0.8	1.5	2.2	mA
Charge pump current rate	I _{DOL} /I _{DOH}	I _{DOMT} ^[6] V _{DO} = V _p / 2	-	3	-	%	
	vs. V _{DO}	I _{DOVD} ^[7] 0.5 V ≤ V _{DO} ≤ V _p - 0.5 V	-	10	-	%	
	vs. T _a	I _{DOTA} ^[8] -40 °C ≤ T _a ≤ +85 °C, V _{DO} = V _p / 2	-	5	-	%	

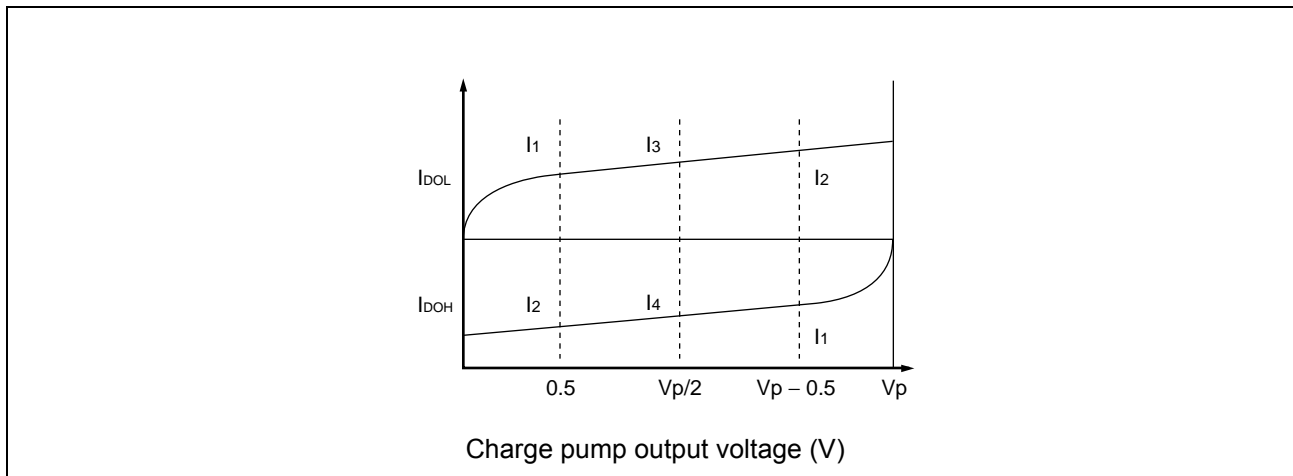
Notes

5. When Charge pump current is measured, set LDS = "L" T1 = "L" and T2 = "H".
6. $V_{CC} = V_p = 2.7 \text{ V, } T_a = +25 \text{ }^\circ\text{C} \left(\frac{|l_3| - |l_4|}{(|l_3| + |l_4|) / 2} \right) \times 100 \text{ (\%)}$.
7. $V_{CC} = V_p = 2.7 \text{ V, } T_a = +25 \text{ }^\circ\text{C} \left(\frac{(|l_2| - |l_1|) / 2}{(|l_1| + |l_2|) / 2} \right) \times 100 \text{ (\%)}$; (Applied to both I_{DOL} and I_{DOH}).
8. $V_{CC} = V_p = 2.7 \text{ V, } \left(\frac{|I_{DO(+85^\circ\text{C})}| - |I_{DO(-40^\circ\text{C})}|}{(|I_{DO(+85^\circ\text{C})}| + |I_{DO(-40^\circ\text{C})}|) / 2} \right) \times 100 \text{ (\%)}$ (Applied to both I_{DOL} and I_{DOH}).

Functional Description

Pulse Swallow Function

- $f_{VCO} = [(P \times N) + A] \times f_{osc} \div R$
 - f_{VCO} : Output frequency of external voltage controlled oscillator (VCO)
 - P : Preset divide ratio of dual modulus prescaler (8 or 16 for IF-PLL, 64 or 128 for RF-PLL)
 - N : Preset divide ratio of binary 11-bit programmable counter (3 to 2,047)
 - A : Preset divide ratio of binary 7-bit swallow counter ($0 \leq A \leq 127, A < N$)
 - f_{osc} : Reference oscillation frequency (OSC_{IN} input frequency)
 - R : Preset divide ratio of binary 14-bit programmable reference counter (3 to 16,383)

	The programmable reference counter for the IF-PLL	The programmable reference counter for the RF-PLL	The programmable counter and the swallow counter for the IF-PLL	The programmable counter and the swallow counter for the RF-PLL
CN1	0	1	0	1
CN2	0	0	1	1

Serial Data Input

The serial data is entered using three pins, Data pin, Clock pin, and LE pin. Programmable dividers of IF/RF-PLL sections, and programmable reference dividers of IF/RF-PLL sections are controlled individually.

The serial data of binary data is entered through Data pin.

On a rising edge of Clock, one bit of the serial data is transferred into the shift register. On a rising edge of load enable signal, the data stored in the shift register is transferred to one of latches depending upon the control bit data setting.

Shift Register Configuration

• Programmable Reference Counter

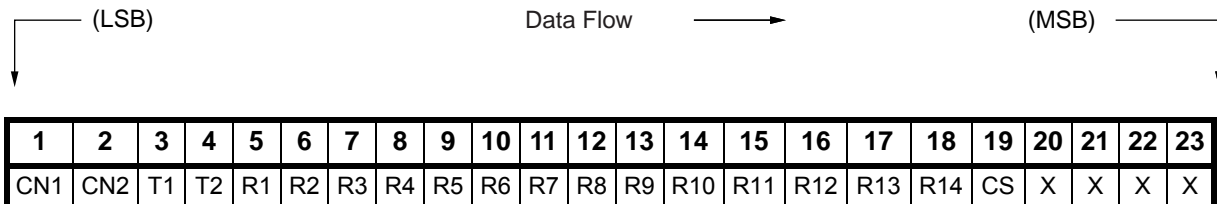

- CS : Charge pump current select bit
- R1 to R14 : Divide ratio setting bits for the programmable reference counter (3 to 16,383)
- T1, T2 : LD/fout output setting bit.
- CN1, CN2 : Control bit
- X : Dummy bits (Set "0" or "1")

Note: Data input with MSB first.

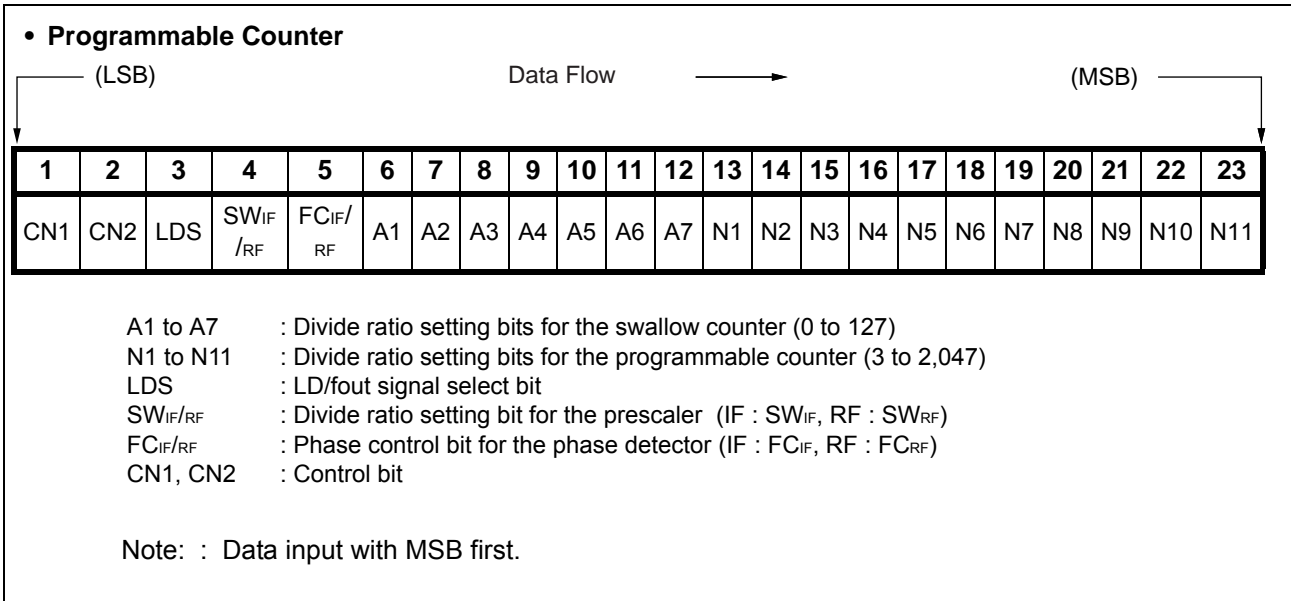

Data Setting

■ Binary 14-bit Programmable Reference Counter Data Setting (R1 to R14)

Divide ratio	R14	R13	R12	R11	R10	R9	R8	R7	R6	R5	R4	R3	R2	R1
3	0	0	0	0	0	0	0	0	0	0	0	0	1	1
4	0	0	0	0	0	0	0	0	0	0	0	1	0	0
•	•	•	•	•	•	•	•	•	•	•	•	•	•	•
•	•	•	•	•	•	•	•	•	•	•	•	•	•	•
•	•	•	•	•	•	•	•	•	•	•	•	•	•	•
16383	1	1	1	1	1	1	1	1	1	1	1	1	1	1

Note: Divide ratio less than 3 is prohibited.

■ Binary 11-bit Programmable Counter Data Setting (N1 to N11)

Divide ratio	N11	N10	N9	N8	N7	N6	N5	N4	N3	N2	N1
3	0	0	0	0	0	0	0	0	0	1	1
4	0	0	0	0	0	0	0	0	1	0	0
•	•	•	•	•	•	•	•	•	•	•	•
•	•	•	•	•	•	•	•	•	•	•	•
•	•	•	•	•	•	•	•	•	•	•	•
2047	1	1	1	1	1	1	1	1	1	1	1

Note: : Divide ratio less than 3 is prohibited.

■ Binary 7-bit Swallow Counter Data Setting (A1 to A7)

Divide ratio	A7	A6	A5	A4	A3	A2	A1
0	0	0	0	0	0	0	0
1	0	0	0	0	0	0	1
•	•	•	•	•	•	•	•
•	•	•	•	•	•	•	•
•	•	•	•	•	•	•	•
127	1	1	1	1	1	1	1

■ Prescaler Data Setting (SW)

Divide ratio	SW = "H"	SW = "L"
Prescaler divide ratio IF-PLL	8/9	16/17
Prescaler divide ratio RF-PLL	64/65	128/129

■ Charge Pump Current Setting (CS)

Current value	CS
±6.0 mA	1
±1.5 mA	0

■ LD/fout output Selectable Bit Setting

LD/fout Pin State		LDS	T1	T2
LD output		0	0	0
		0	1	0
		0	1	1
fout outputs	fr _{IF}	1	0	0
	fr _{RF}	1	1	0
	fp _{IF}	1	0	1
	fp _{RF}	1	1	1

■ Phase Comparator Phase Switching Data Setting (FC_{IF}, FC_{RF})

Phase comparator input	FC _{IF} = "H"	FC _{RF} = "H"	FC _{IF} = "L"	FC _{RF} = "L"
	Do _{IF}	Do _{RF}	Do _{IF}	Do _{RF}
fr > fp	H		L	
fr < fp	L		H	
fr = fp	Z		Z	

Z : High-impedance

Depending upon the VCO and LPF polarity, FC bit should be set.

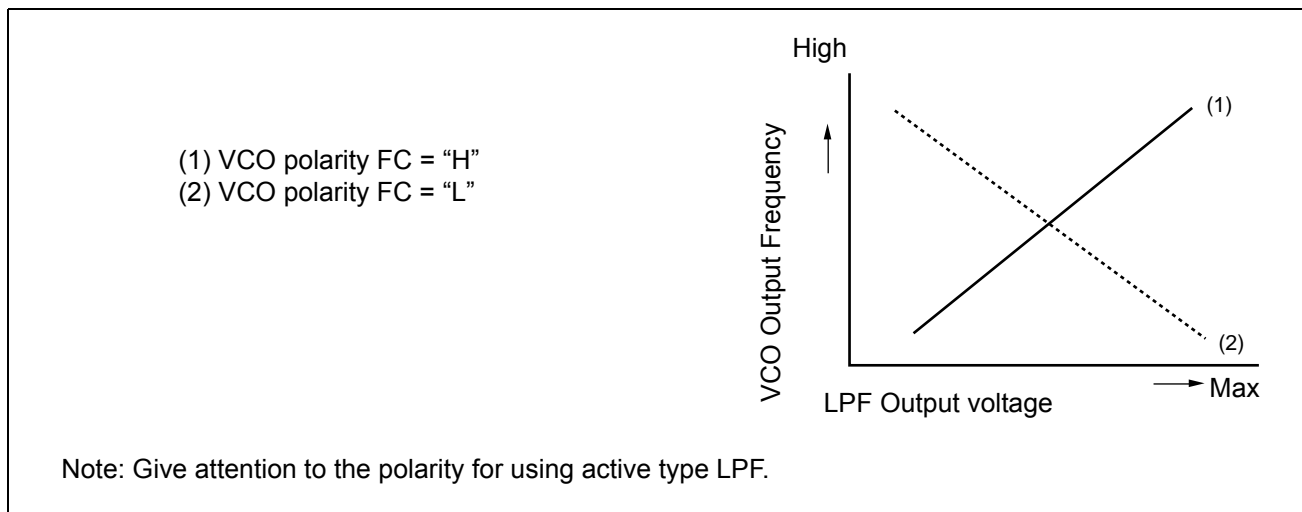

Power Saving Mode (Intermittent Mode Control Circuit)

Status	PS pins
Normal mode	H
Power saving mode	L

The intermittent mode control circuit reduces the PLL power consumption.

By setting the PS pin low, the device enters into the power saving mode, reducing the current consumption. See the Electrical Characteristics chart for the specific value.

The phase detector output, Do, becomes high impedance.

For the dual PLL, the lock detector, LD, is as shown in the LD Output Logic table.

Setting the PS pin high, releases the power saving mode, and the device works normally.

The intermittent mode control circuit also ensures a smooth startup when the device returns to normal operation. When the PLL is returned to normal operation, the phase comparator output signal is unpredictable. This is because of the unknown relationship between the comparison frequency (fp) and the reference frequency (fr) which can cause a major change in the comparator output, resulting in a VCO frequency jump and an increase in lockup time.

To prevent a major VCO frequency jump, the intermittent mode control circuit limits the magnitude of the error signal from the phase detector when it returns to normal operation.

Notes: ■ When power (Vcc) is first applied, the device must be in standby mode, PS = Low, for at least 1 μs.

■ PS pins must be set at “L” at Power-ON.

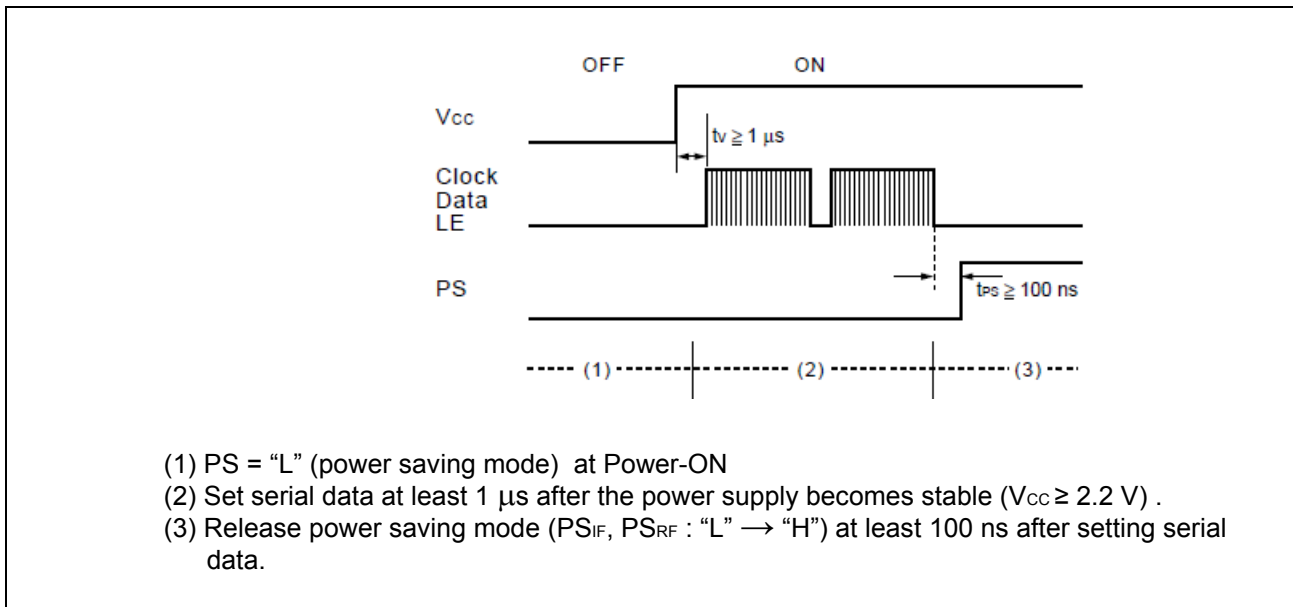

Serial Data Input Timing

Divide ratio is performed through a serial interface using the Data pin, Clock pin, and LE pin. Setting data is read into the shift register at the rise of the clock signal, and transferred to a latch at the rise of the LE signal. The following diagram shows the data input timing.

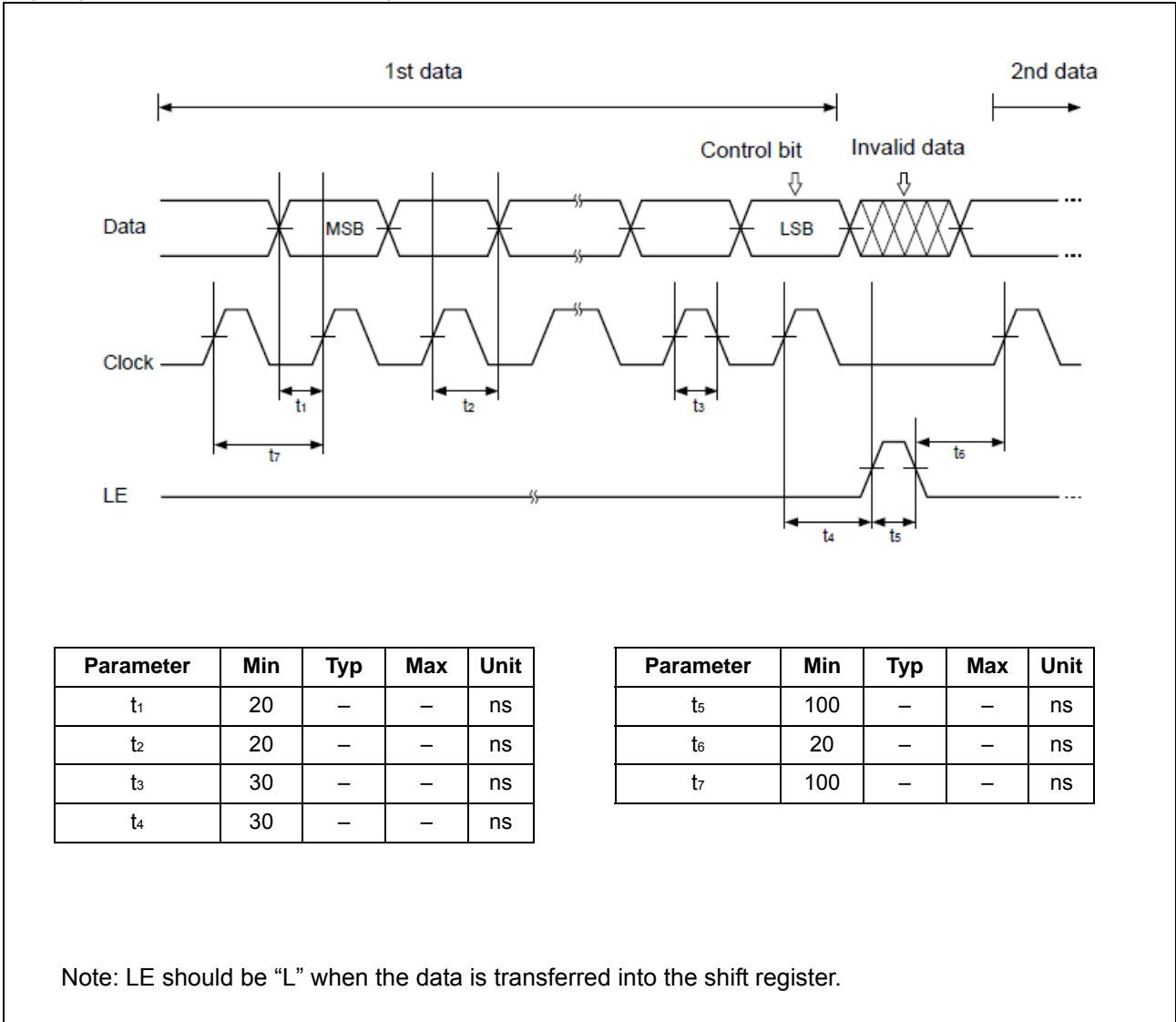

Phase Comparator Output Waveform

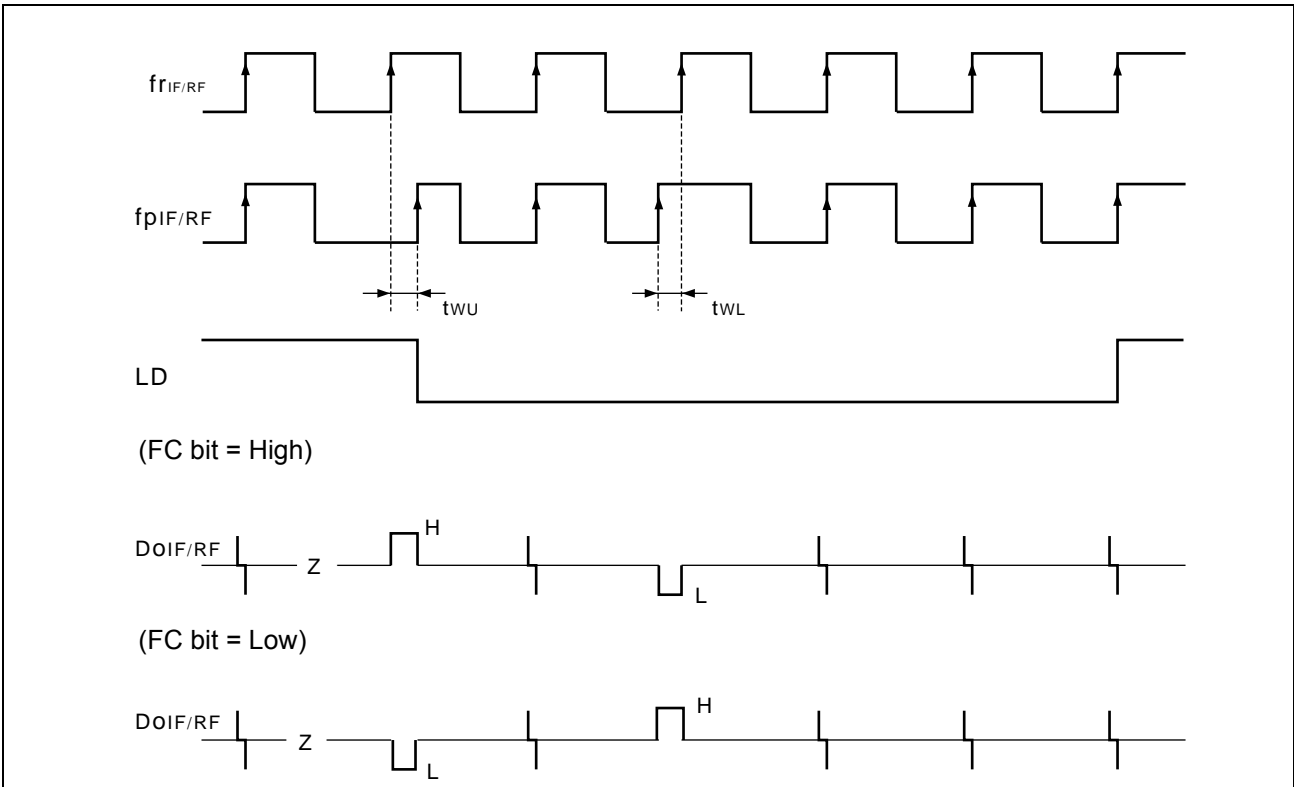

LD Output Logic

IF-PLL section	RF-PLL section	LD output
Locking state/Power saving state	Locking state/Power saving state	H
Locking state/Power saving state	Unlocking state	L
Unlocking state	Locking state/Power saving state	L
Unlocking state	Unlocking state	L

- Note:
- Phase error detection range = -2π to $+2\pi$
 - Pulses on $DoIF/RF$ signals are output to prevent dead zone.
 - LD output becomes low when phase error is t_{WU} or more.
 - LD output becomes high when phase error is t_{WL} or less and continues to be so for three cycles or more.
 - t_{WU} and t_{WL} depend on OSC_{IN} input frequency as follows.
 - $t_{WU} \geq 2/f_{osc}$: for example, $t_{WU} \geq 156.3$ ns when $f_{osc} = 12.8$ MHz
 - $t_{WU} \leq 4/f_{osc}$: for example, $t_{WL} \leq 312.5$ ns when $f_{osc} = 12.8$ MHz

Test Circuit (for Measuring Input Sensitivity f_{in}/OSC_{IN})

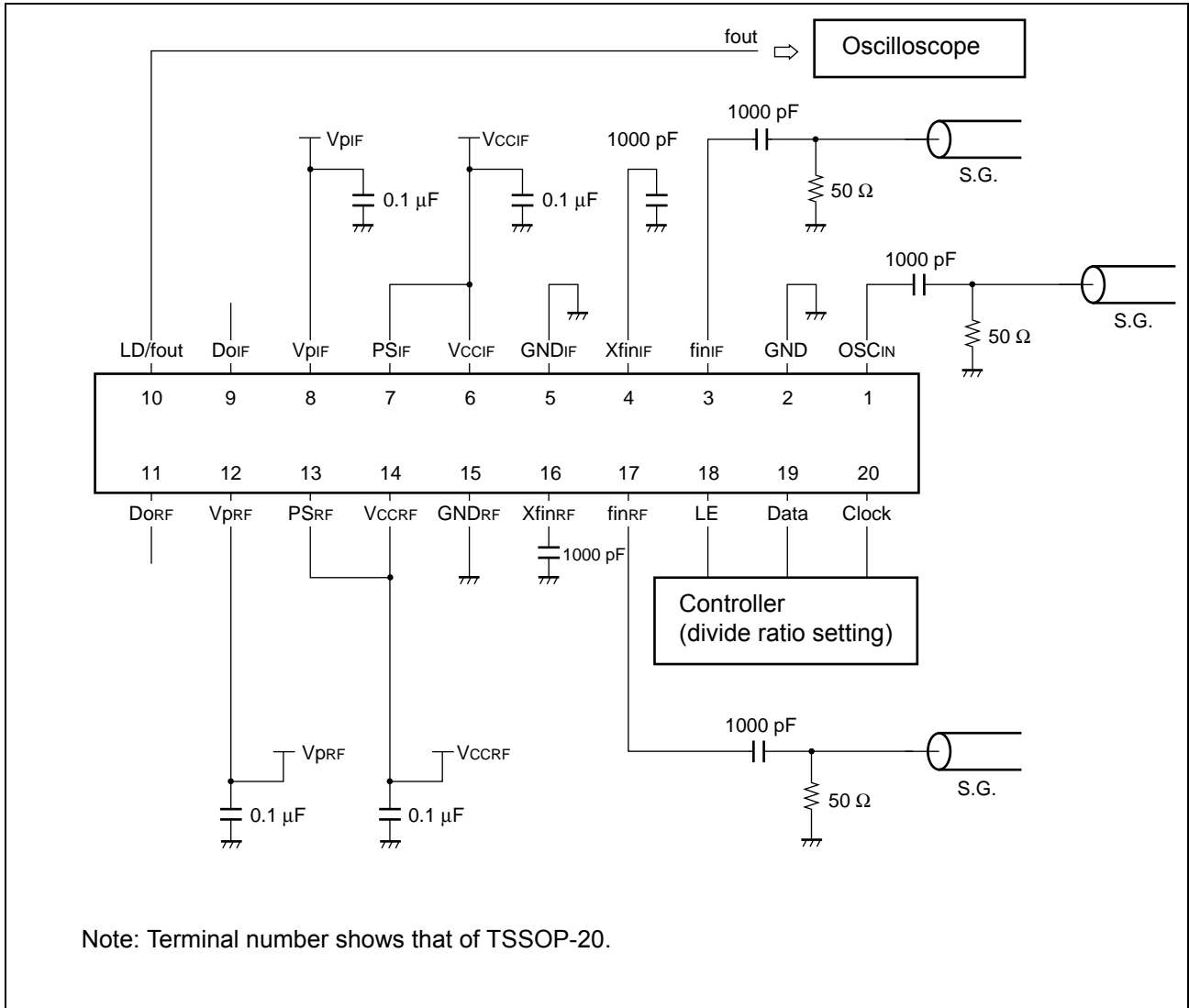

Typical Characteristics

Fin Input Sensitivity

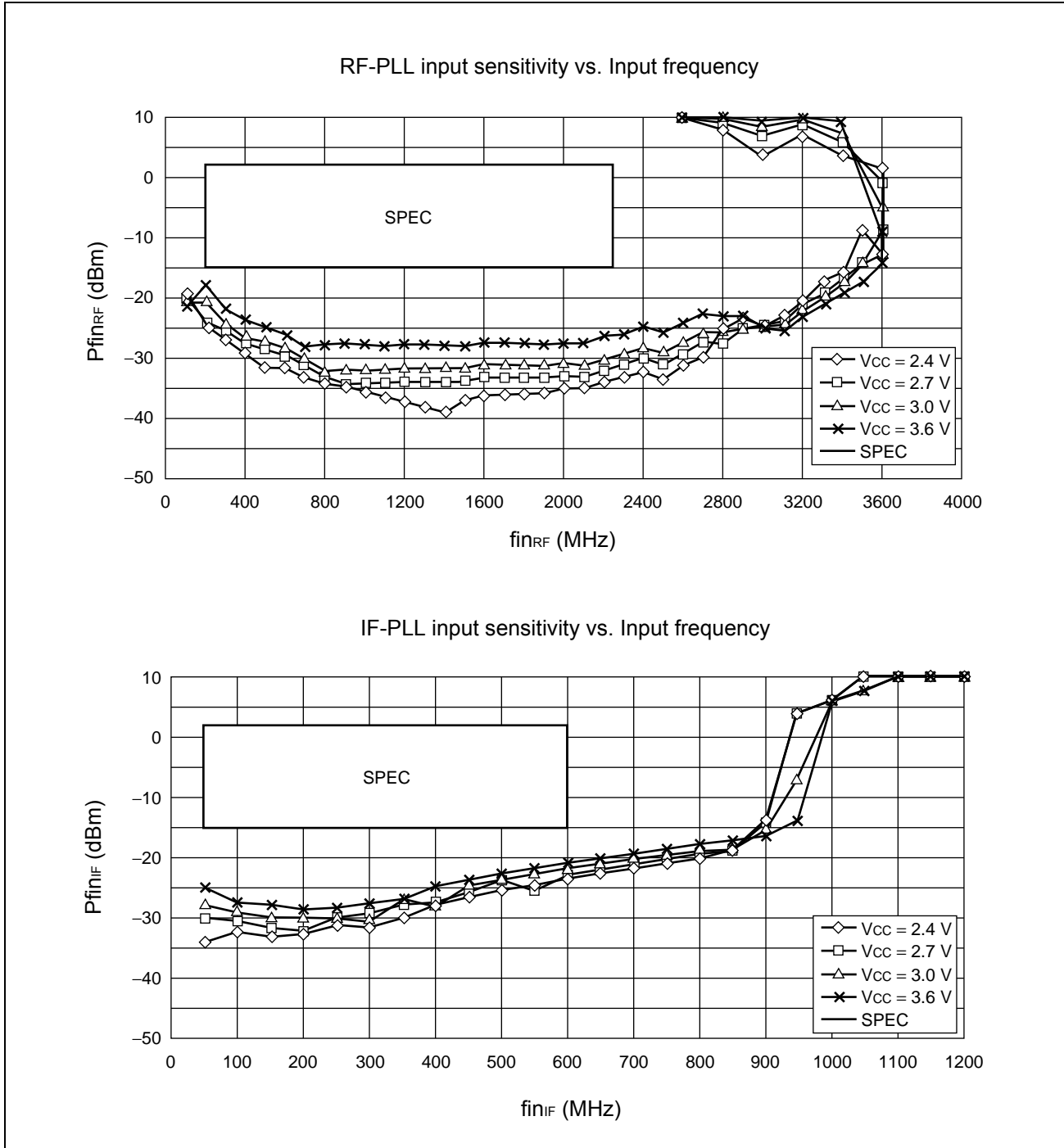

OSC_{IN} Input Sensitivity

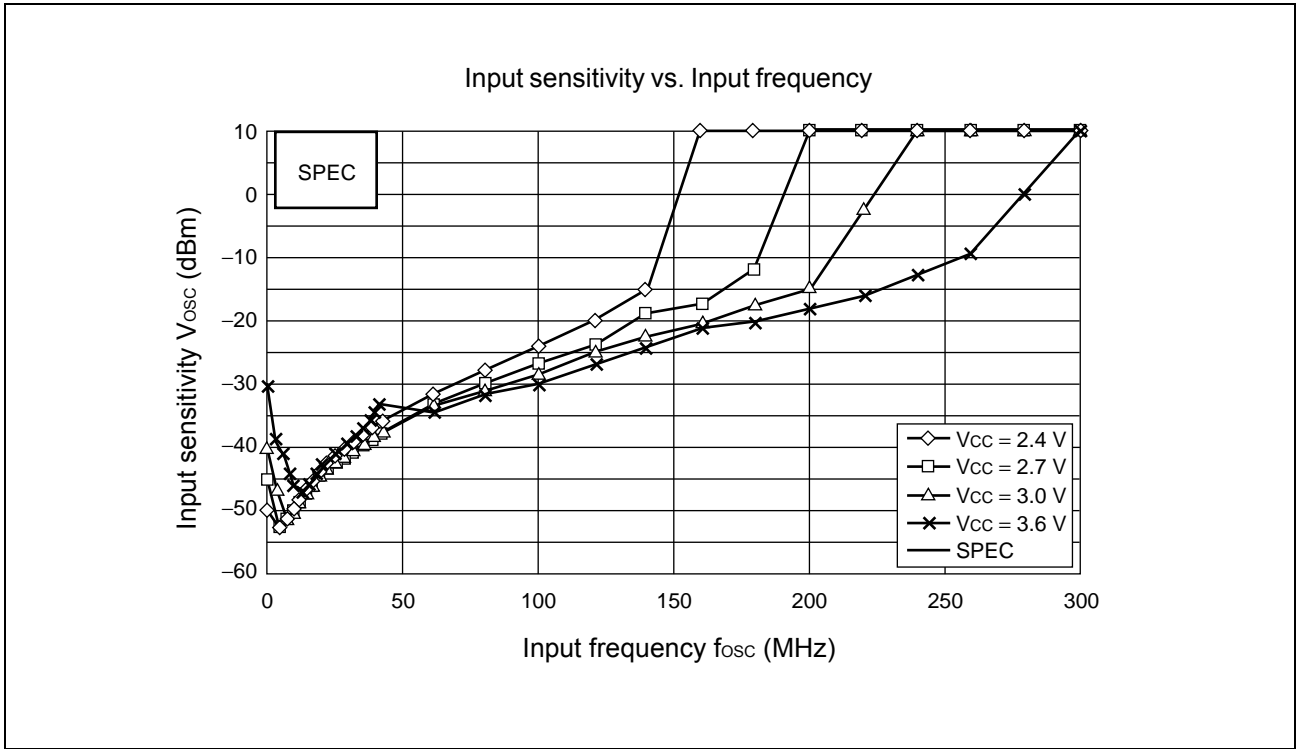

RF-PLL Do Output Current

- 1.5 mA mode

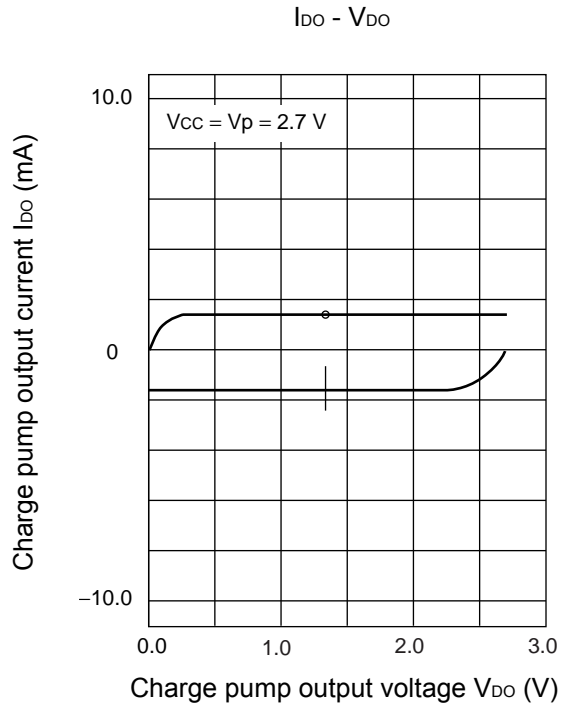

- 6.0 mA mode

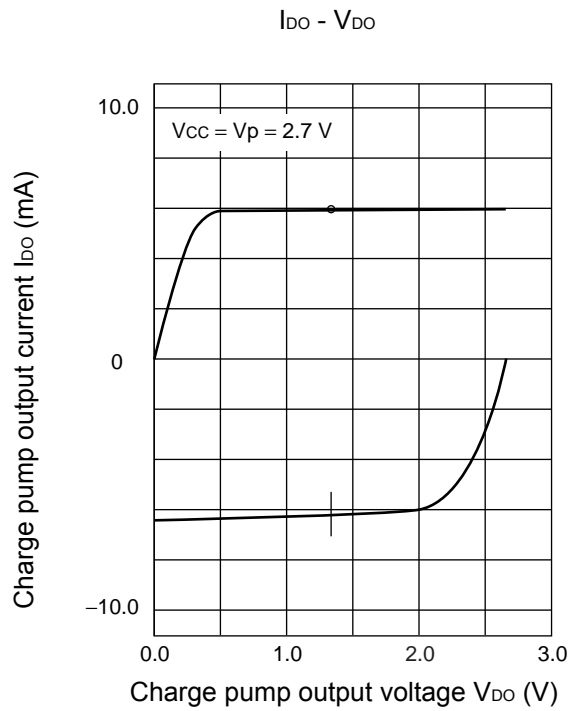

IF-PLL Do Output Current

- 1.5 mA mode

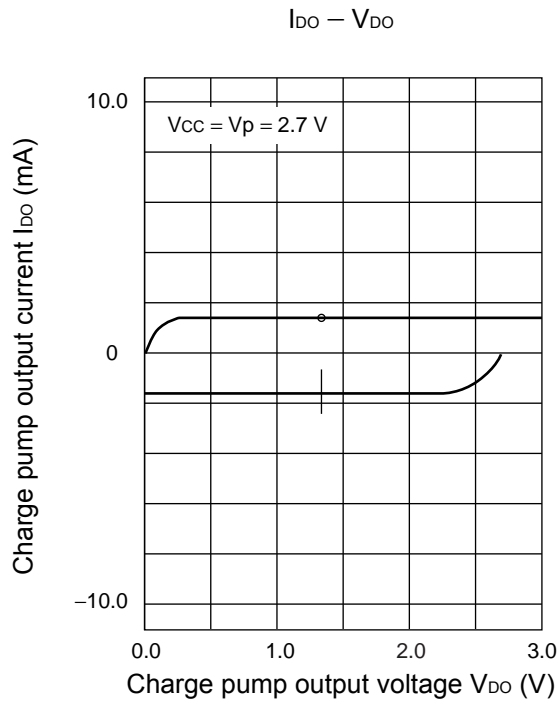

- 6.0 mA mode

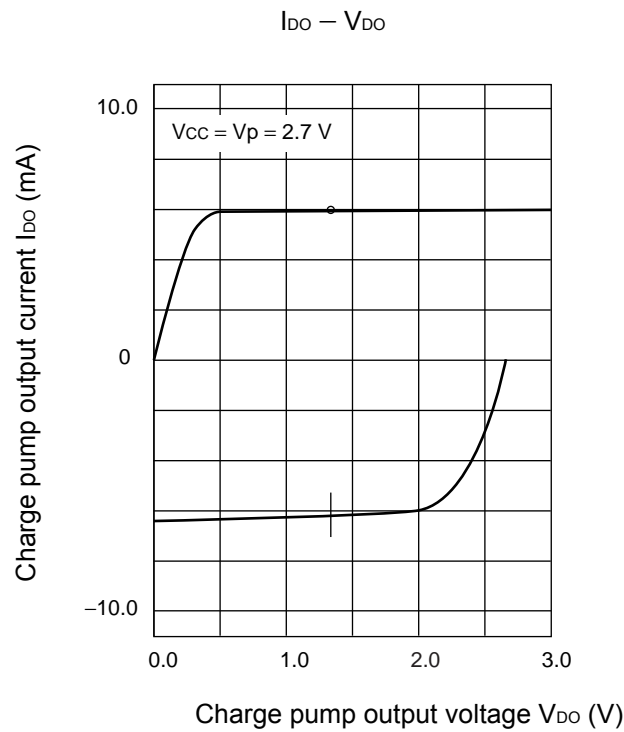

fin Input Impedance

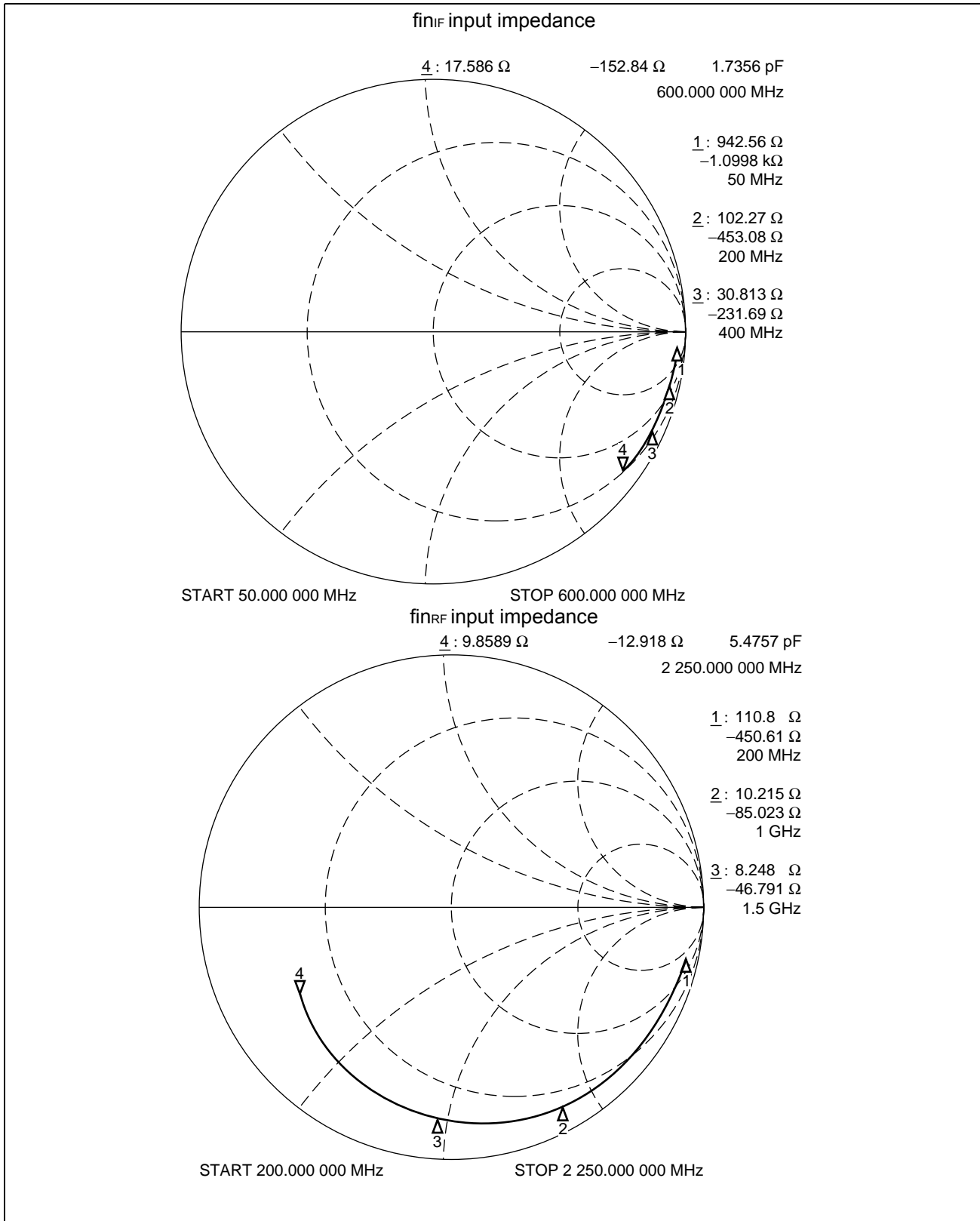

OSC_{IN} Input Impedance

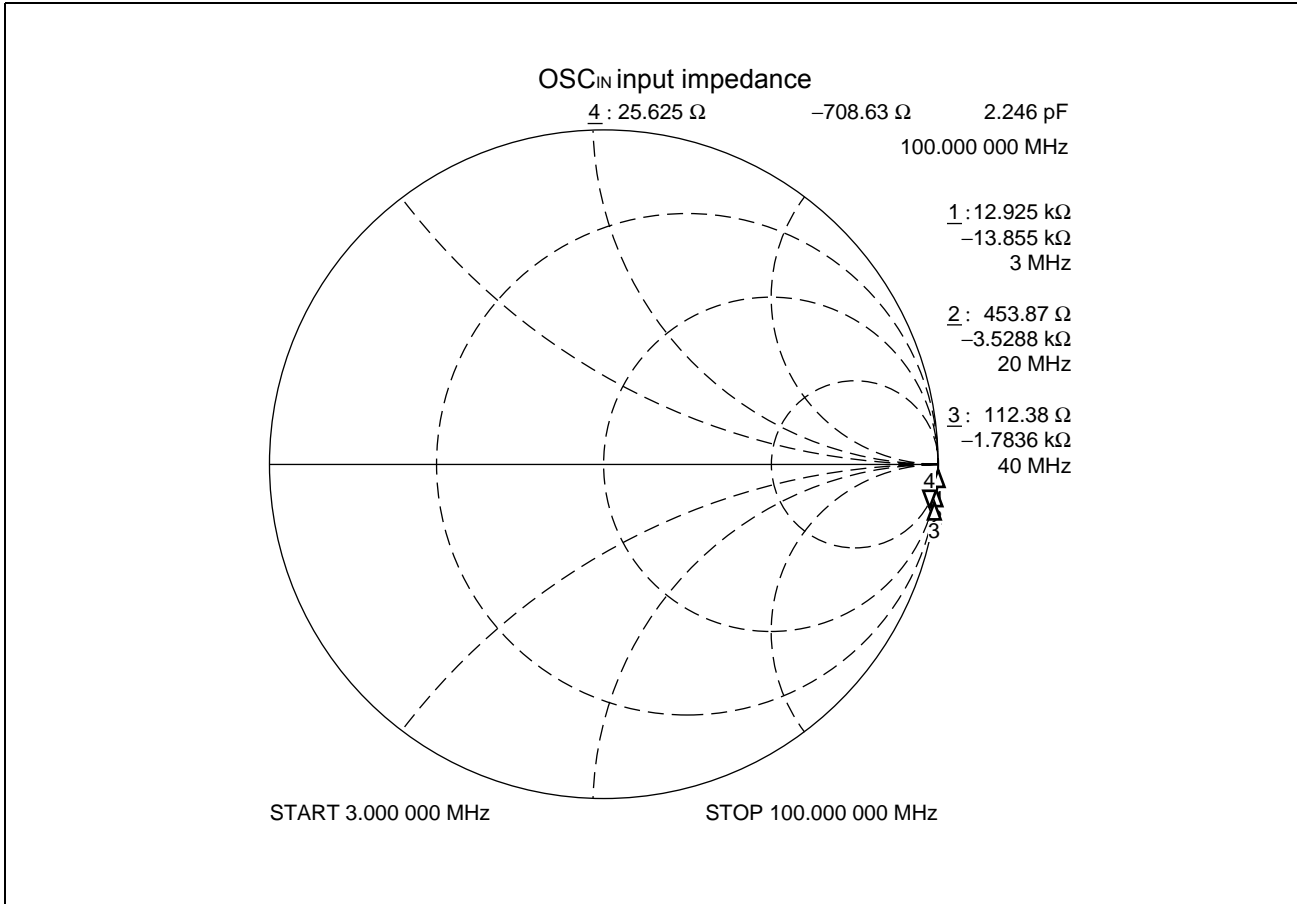

Reference Information (for Lock-up Time, Phase Noise, and Reference Leakage)

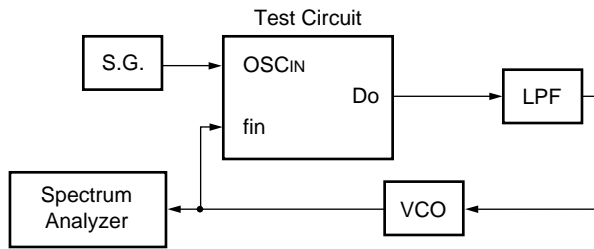

$f_{vco} = 1607 \text{ MHz}$ $V_{cc} = 3.0 \text{ V}$
 $K_v = 30 \text{ MHz/V}$ $V_{vco} = 2.3 \text{ V}$
 $f_r = 25 \text{ kHz}$ $T_a = +25 \text{ }^\circ\text{C}$
 $f_{osc} = 14.4 \text{ MHz}$ $CP : 6 \text{ mA mode}$
 LPF
 VCO : FUJITSU MEDIA DEVICES
 (VC-2R3A50-1619)

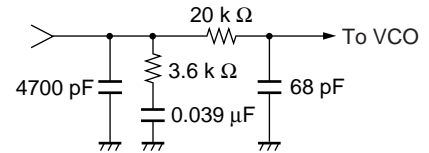

• PLL Reference Leakage

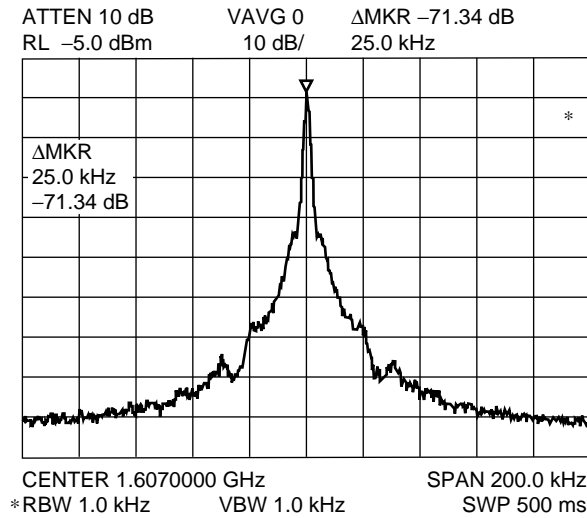

• PLL Phase Noise

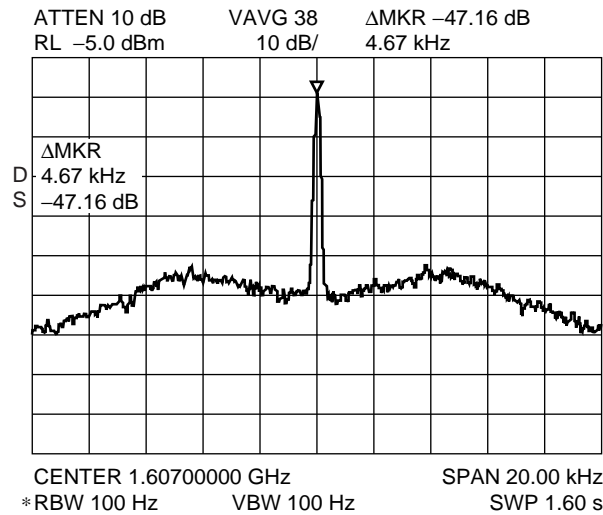

• PLL Lock Up time

1607 MHz → 1631 MHz within ± 1 kHz
Lch → Hch 1.09 ms

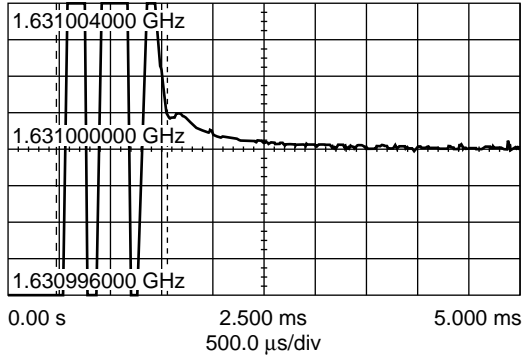

• PLL Lock Up time

1631 MHz → 1607 MHz within ± 1 kHz
Hch → Lch 1.28 ms

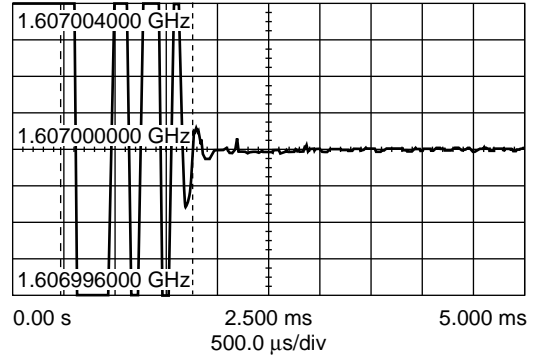

Application Example

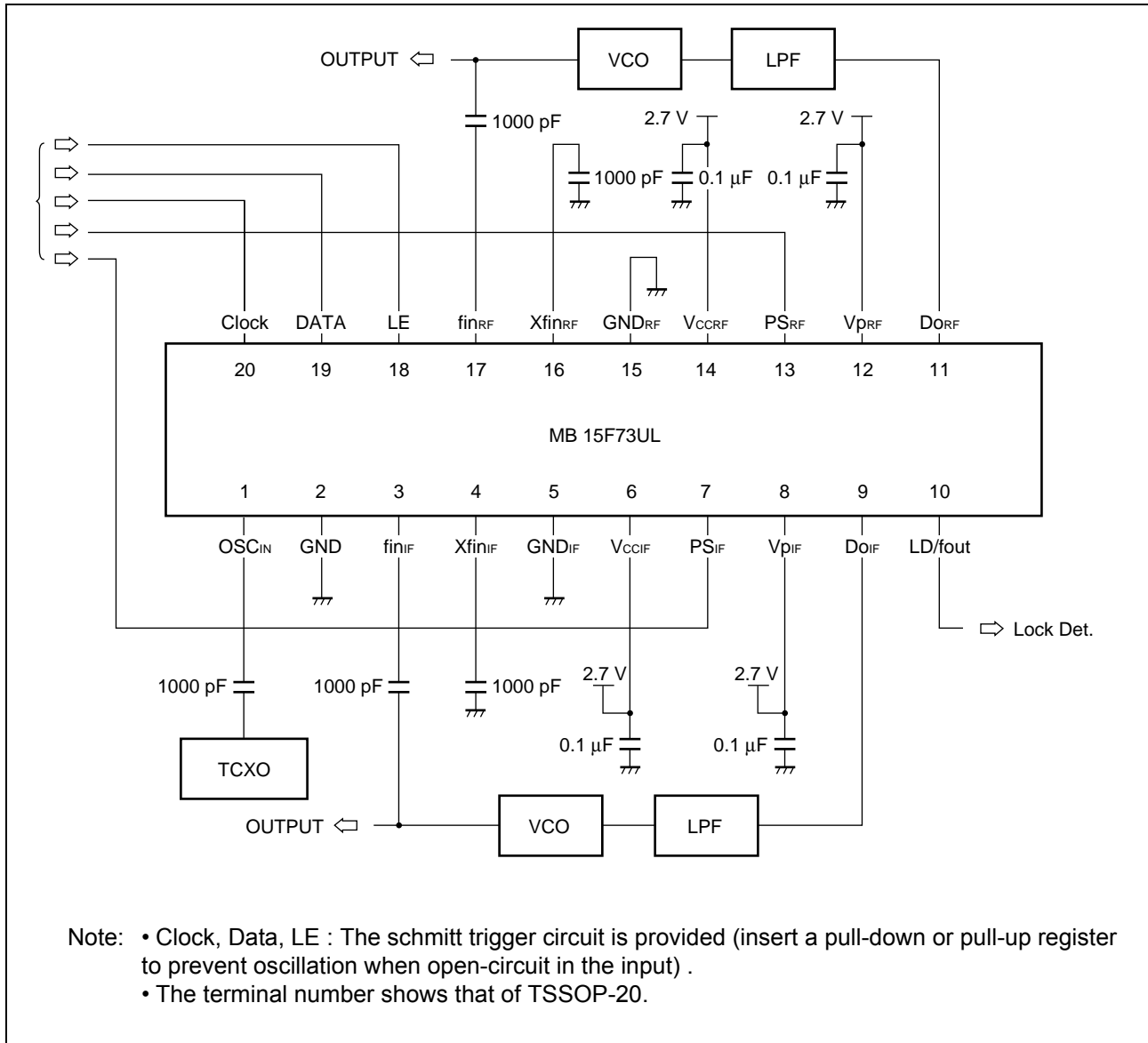

Usage Precautions

1. V_{CCRF} , V_{PRF} , V_{CCIF} and V_{PIF} must be equal voltage.
 - a. Even if either RF-PLL or IF-PLL is not used, power must be supplied to V_{CCRF} , V_{PRF} , V_{CCIF} and V_{PIF} to keep them equal. It is recommended that the non-use PLL is controlled by power saving function.
2. To protect against damage by electrostatic discharge, note the following handling precautions :
 - a. Store and transport devices in conductive containers.
 - b. Use properly grounded workstations, tools, and equipment.
 - c. Turn off power before inserting or removing this device into or from a socket.
 - d. Protect leads with conductive sheet, when transporting a board mounted device.

Ordering Information

Part number	Package	Remarks
MB15F73ULPFT	20-pin, plastic TSSOP (FPT-20P-M06)	
MB15F73ULWQN	20-pin, Plastic QFN (LCC-20P-M63)	

Package Dimensions

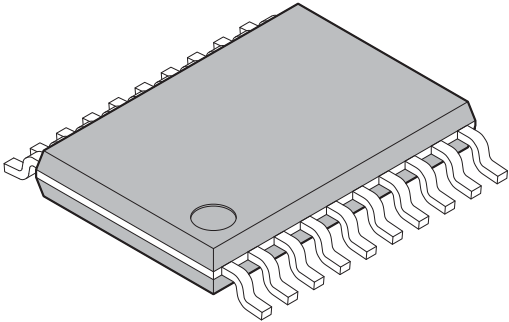
<p>20-pin plastic TSSOP</p>  <p>(FPT-20P-M06)</p>	Lead pitch	0.65 mm
	Package width × package length	4.40 × 6.50 mm
	Lead shape	Gullwing
	Sealing method	Plastic mold
	Mounting height	1.10 mm MAX
	Weight	0.08g
	Code (Reference)	P-TSSOP20-4.4×6.5-0.65

20-pin plastic TSSOP (FPT-20P-M06)

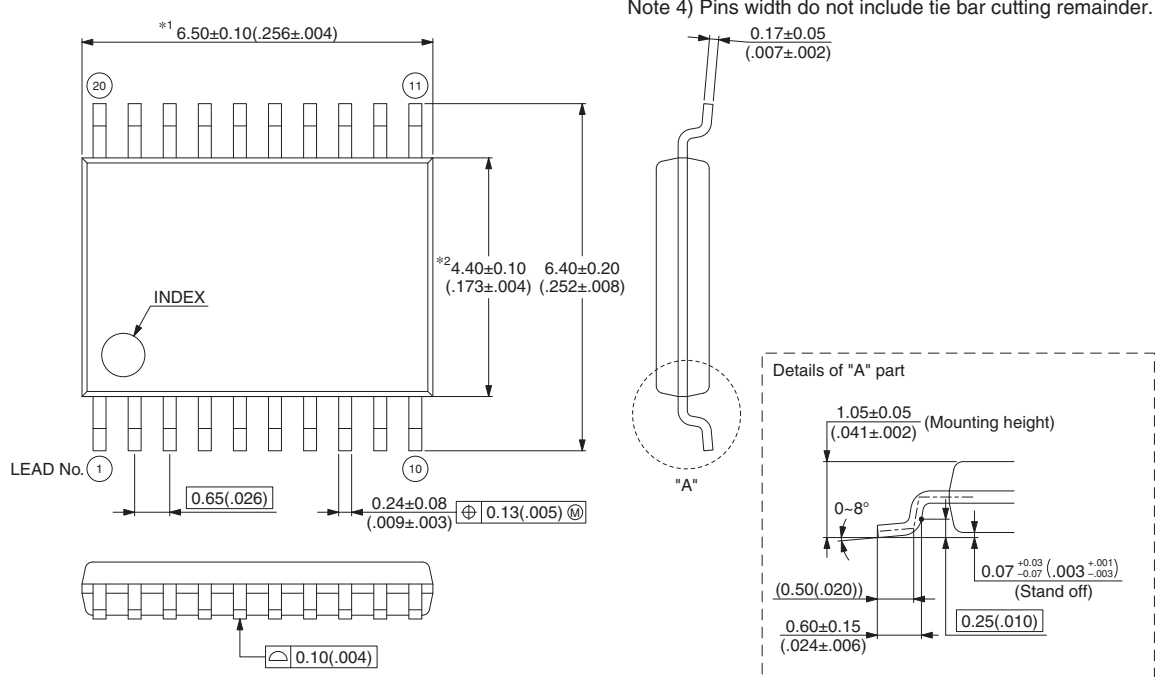

Note 1) *1 : Resin protrusion. (Each side : +0.15 (.006) Max).
 Note 2) *2 : These dimensions do not include resin protrusion.
 Note 3) Pins width and pins thickness include plating thickness.
 Note 4) Pins width do not include tie bar cutting remainder.

Dimensions in mm (inches).
 Note: The values in parentheses are reference values.

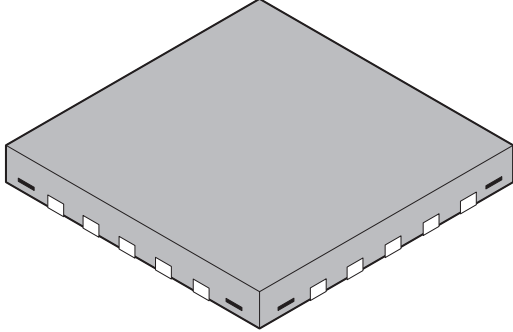
<p style="text-align: center;">20-pin plastic QFN</p>  <p style="text-align: center;">(LCC-20P-M63)</p>	Lead pitch	0.50 mm	
	Package width × package length	4.00 mm × 4.00 mm	
	Sealing method	Plastic mold	
	Mounting height	0.80 mm MAX	
	Weight	0.04 g	

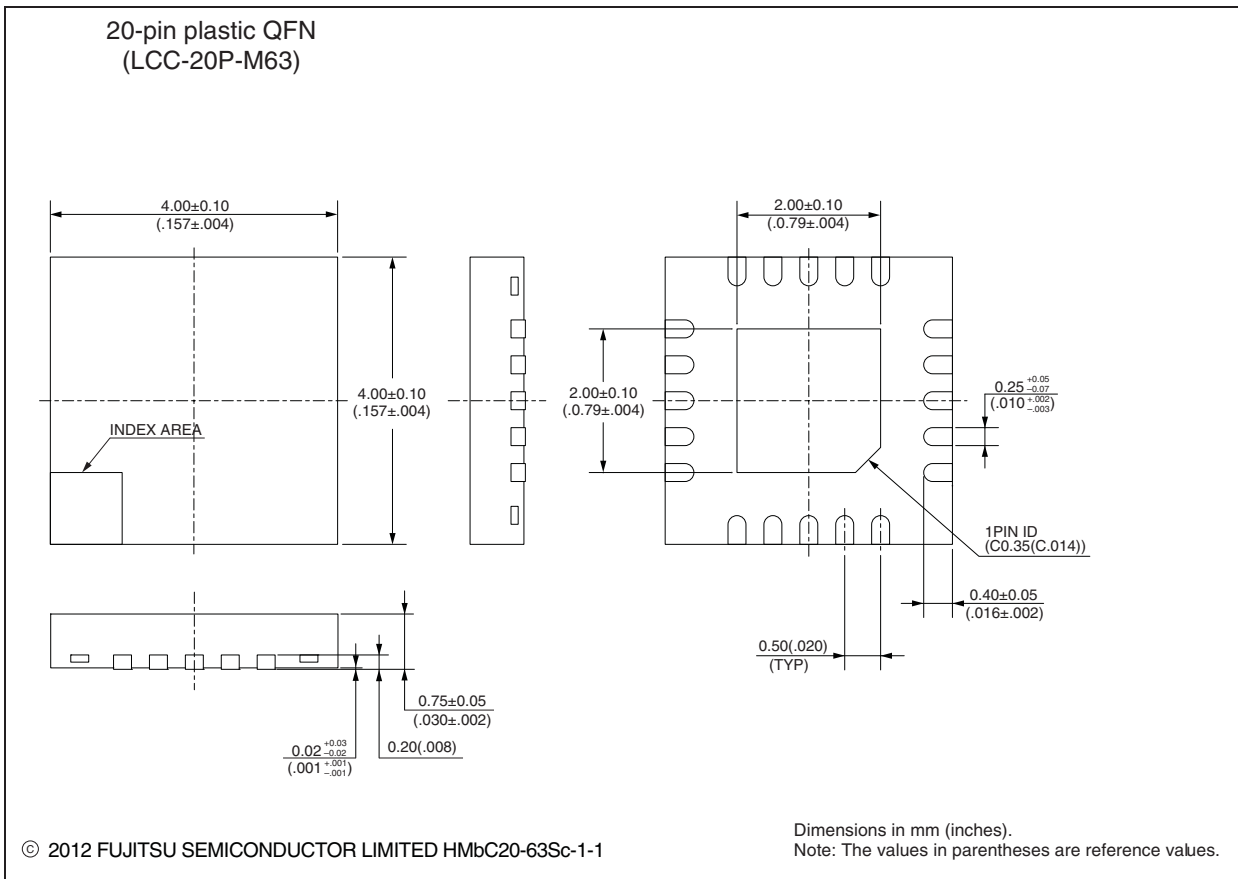

Document History

Spansion Publication Code: DS04-21368-2E

Document Title: MB15F73UL ASSP Dual Serial Input PLL Frequency Synthesizer Datasheet Document Number: 002-08480				
Revision	ECN	Orig. of Change	Submission Date	Description of Change
**	–	TAOA	05/31/2012	New datasheet
*A	5575514	TAOA	01/05/2017	Converted to Cypress template.

Sales, Solutions, and Legal Information

Worldwide Sales and Design Support

Cypress maintains a worldwide network of offices, solution centers, manufacturer's representatives, and distributors. To find the office closest to you, visit us at [Cypress Locations](#).

Products

ARM® Cortex® Microcontrollers	cypress.com/arm
Automotive	cypress.com/automotive
Clocks & Buffers	cypress.com/clocks
Interface	cypress.com/interface
Internet of Things	cypress.com/iot
Memory	cypress.com/memory
Microcontrollers	cypress.com/mcu
PSoC	cypress.com/psoc
Power Management ICs	cypress.com/pmic
Touch Sensing	cypress.com/touch
USB Controllers	cypress.com/usb
Wireless Connectivity	cypress.com/wireless

PSoC®Solutions

[PSoC 1](#) | [PSoC 3](#) | [PSoC 4](#) | [PSoC 5LP](#)

Cypress Developer Community

[Forums](#) | [WICED IOT Forums](#) | [Projects](#) | [Video](#) | [Blogs](#) | [Training](#) | [Components](#)

Technical Support

cypress.com/support

© Cypress Semiconductor Corporation, 2001-2017. This document is the property of Cypress Semiconductor Corporation and its subsidiaries, including Spansion LLC ("Cypress"). This document, including any software or firmware included or referenced in this document ("Software"), is owned by Cypress under the intellectual property laws and treaties of the United States and other countries worldwide. Cypress reserves all rights under such laws and treaties and does not, except as specifically stated in this paragraph, grant any license under its patents, copyrights, trademarks, or other intellectual property rights. If the Software is not accompanied by a license agreement and you do not otherwise have a written agreement with Cypress governing the use of the Software, then Cypress hereby grants you a personal, non-exclusive, nontransferable license (without the right to sublicense) (1) under its copyright rights in the Software (a) for Software provided in source code form, to modify and reproduce the Software solely for use with Cypress hardware products, only internally within your organization, and (b) to distribute the Software in binary code form externally to end users (either directly or indirectly through resellers and distributors), solely for use on Cypress hardware product units, and (2) under those claims of Cypress's patents that are infringed by the Software (as provided by Cypress, unmodified) to make, use, distribute, and import the Software solely for use with Cypress hardware products. Any other use, reproduction, modification, translation, or compilation of the Software is prohibited.

TO THE EXTENT PERMITTED BY APPLICABLE LAW, CYPRESS MAKES NO WARRANTY OF ANY KIND, EXPRESS OR IMPLIED, WITH REGARD TO THIS DOCUMENT OR ANY SOFTWARE OR ACCOMPANYING HARDWARE, INCLUDING, BUT NOT LIMITED TO, THE IMPLIED WARRANTIES OF MERCHANTABILITY AND FITNESS FOR A PARTICULAR PURPOSE. To the extent permitted by applicable law, Cypress reserves the right to make changes to this document without further notice. Cypress does not assume any liability arising out of the application or use of any product or circuit described in this document. Any information provided in this document, including any sample design information or programming code, is provided only for reference purposes. It is the responsibility of the user of this document to properly design, program, and test the functionality and safety of any application made of this information and any resulting product. Cypress products are not designed, intended, or authorized for use as critical components in systems designed or intended for the operation of weapons, weapons systems, nuclear installations, life-support devices or systems, other medical devices or systems (including resuscitation equipment and surgical implants), pollution control or hazardous substances management, or other uses where the failure of the device or system could cause personal injury, death, or property damage ("Unintended Uses"). A critical component is any component of a device or system whose failure to perform can be reasonably expected to cause the failure of the device or system, or to affect its safety or effectiveness. Cypress is not liable, in whole or in part, and you shall and hereby do release Cypress from any claim, damage, or other liability arising from or related to all Unintended Uses of Cypress products. You shall indemnify and hold Cypress harmless from and against all claims, costs, damages, and other liabilities, including claims for personal injury or death, arising from or related to any Unintended Uses of Cypress products.

Cypress, the Cypress logo, Spansion, the Spansion logo, and combinations thereof, WICED, PSoC, CapSense, EZ-USB, F-RAM, and Traveo are trademarks or registered trademarks of Cypress in the United States and other countries. For a more complete list of Cypress trademarks, visit cypress.com. Other names and brands may be claimed as property of their respective owners.