

阅读申明

- 1.本站收集的数据手册和产品资料都来自互联网，版权归原作者所有。如读者和版权方有任何异议请及时告之，我们将妥善解决。
- 2.本站提供的中文数据手册是英文数据手册的中文翻译，其目的是协助用户阅读，该译文无法自动跟随原稿更新，同时也可能存在翻译上的不当。建议读者以英文原稿为参考以便获得更精准的信息。
- 3.本站提供的产品资料，来自厂商的技术支持或者使用者的心得体会等，其内容可能存在描述上的差异，建议读者做出适当判断。
- 4.如需与我们联系，请发邮件到marketing@iczoom.com，主题请标有“数据手册”字样。

Read Statement

1. The datasheets and other product information on the site are all from network reference or other public materials, and the copyright belongs to the original author and original published source. If readers and copyright owners have any objections, please contact us and we will deal with it in a timely manner.
2. The Chinese datasheets provided on the website is a Chinese translation of the English datasheets. Its purpose is for reader's learning exchange only and do not involve commercial purposes. The translation cannot be automatically updated with the original manuscript, and there may also be improper translations. Readers are advised to use the English manuscript as a reference for more accurate information.
3. All product information provided on the website refer to solutions from manufacturers' technical support or users the contents may have differences in description, and readers are advised to take the original article as the standard.
4. If you have any questions, please contact us at marketing@iczoom.com and mark the subject with "Datasheets" .



MK2712 NTSC/PAL Clock Source

Description

The MK2712 is the ideal way to generate clocks for NTSC/PAL video encoders and decoders. Stored in the device are two sets of popular frequencies for NTSC and PAL. In an 8 pin SOIC, the chip can save component count, board space, and cost over surface mount crystals and oscillators, and increase reliability by eliminating one or two mechanical devices from the board. The power down pin turns off the device, drawing less than 20 μ A.

ICS/MicroClock offers many other clocks for computers and computer peripherals. Consult us when you need to remove crystals and oscillators from your board.

Features

- Packaged in 8 pin SOIC
- Ideal for chips such as Analog Devices AD722 and Brooktree BT819
- Input clock frequency of 27.0000 MHz
- Power down turns off chip
- Output enable tri-states output for system testing
- Frequencies are within 1 ppm with accurate input clock
- Low jitter
- Output clock frequencies of 14.31818MHz, 17.7345MHz, 28.6364MHz, or 35.46896MHz
- 25mA drive capability at TTL levels
- 3.3V or 5V supply voltage
- Advanced, low power CMOS process
- Insensitive to input clock duty cycle

Block Diagram

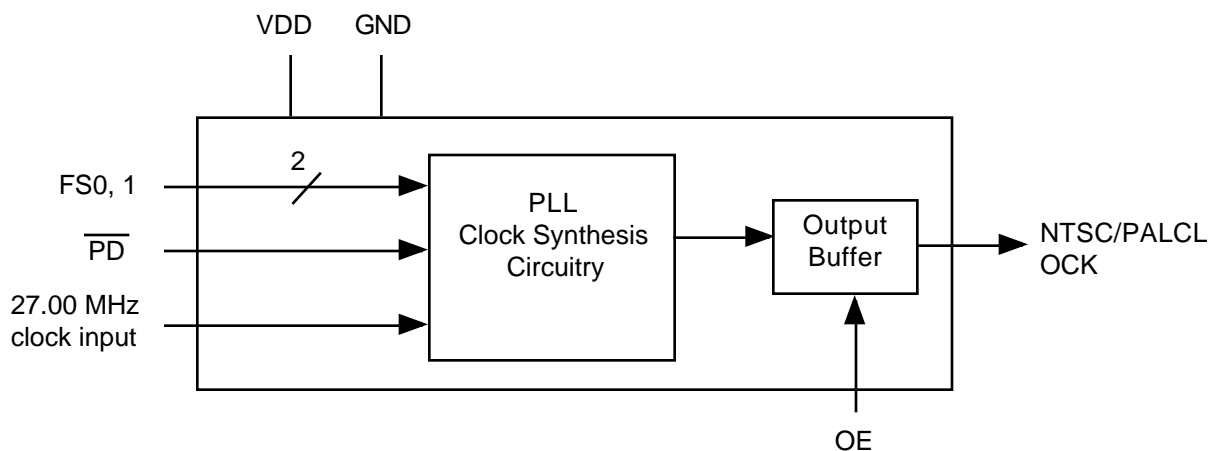



MK2712 NTSC/PAL Clock Source

Pin Assignment

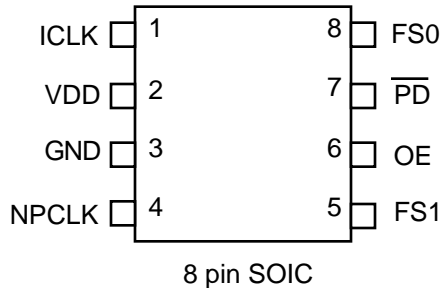

Decoding Table

FS1	FS0	NPCLK (MHz)	Error (ppm)
0	0	14.31818	0.3 ppm
0	1	17.73447	0.3 ppm
1	0	28.63636	0.3 ppm
1	1	35.46894	0.3 ppm

Pin Descriptions

Number	Name	Type	Description
1	ICLK	I	Input Clock. Connect to a 27.0000 MHz clock.
2	VDD	P	Connect to +3.3V or +5V.
3	GND	P	Connect to ground.
4	NPCLK	O	NTSC or PAL output clock. Selected by FS1, FS0 per tables above.
5	FS1	I	Frequency Select pin #1. Selects NTSC or PAL frequency per table above.
6	OE	I	Output Enable. Tri-states clock output when this input is low. Internal pull-up.
7	\overline{PD}	I	Power Down. Active low. Clocks stop low.
8	FS0	I	Frequency Select pin #0. Selects NTSC or PAL frequency per table above.

Key: I = Input, O = output, P = power supply connection

External Components/Crystal Selection

A minimum number of external components are required for proper oscillation. Connect a 27.000 MHz clock to ICLK. A decoupling capacitor of 0.1 μ F should be connected between VDD and GND on pins 2 and 3, and a 33 terminating resistor should be used on the clock output if the trace is longer than 1 inch.



MK2712 NTSC/PAL Clock Source

Electrical Specifications

Parameter	Conditions	Minimum	Typical	Maximum	Units
ABSOLUTE MAXIMUM RATINGS (note 1)					
Supply Voltage, VDD	Referenced to GND			7	V
Inputs	Referenced to GND	-0.5		VDD+.5V	V
Clock Outputs	Referenced to GND	-0.5		VDD+.5V	V
Ambient Operating Temperature		0		70	°C
Soldering Temperature	Max of 10 seconds			260	°C
Storage temperature		-65		150	°C
DC CHARACTERISTICS (at 5.0V unless otherwise noted)					
Operating Voltage, VDD		4.5		5.5	V
Input High Voltage, VIH, input clock only	ICLK pin	3.5	2.5		V
Input Low Voltage, VIL, input clock only	ICLK pin		2.5	1.5	V
Input High Voltage, VIH		2			V
Input Low Voltage, VIL				0.8	V
Output High Voltage, VOH	IOH=-4mA	VDD-0.4			V
Output High Voltage, VOH	IOH=-25mA	2.4			V
Output Low Voltage, VOL	IOL=25mA			0.4	V
Operating Supply Current, IDD	No Load, FS1=1. FS0=1		13		mA
Power Down Supply Current, IDDPD	No Load		10		µA
Input Capacitance			5		pF
Actual Mean Frequency versus Target	With exact ICLK		0.3	0.3	ppm
AC CHARACTERISTICS (at 5.0V unless otherwise noted)					
Input Clock Frequency			27		MHz
Input Clock Duty Cycle	Time above 2.5V	20		80	%
Output Clock Rise Time	0.8 to 2.0V			1.5	ns
Output Clock Fall Time	2.0 to 0.8V			1.5	ns
Output Clock Duty Cycle	Time above 1.5V	40	50	60	%
Absolute Maximum Clock Period Jitter, 15 pF	Variation from mean		± 90		ps
One Sigma Clock Period Jitter, 15 pF load			30		ps
Absolute Maximum Clock Period Jitter, 15 pF	VDD=3.3V		± 180		ps
One Sigma Clock Period Jitter, 15 pF load	VDD=3.3V		50		ps

Notes:

- Stresses beyond those listed under Absolute Maximum Ratings could cause permanent damage to the device. Prolonged exposure to levels above the operating limits but below the Absolute Maximums may affect device reliability.
- Typical values are at 25°C.



MK2712 NTSC/PAL Clock Source

Package Outline and Package Dimensions

8 pin SOIC

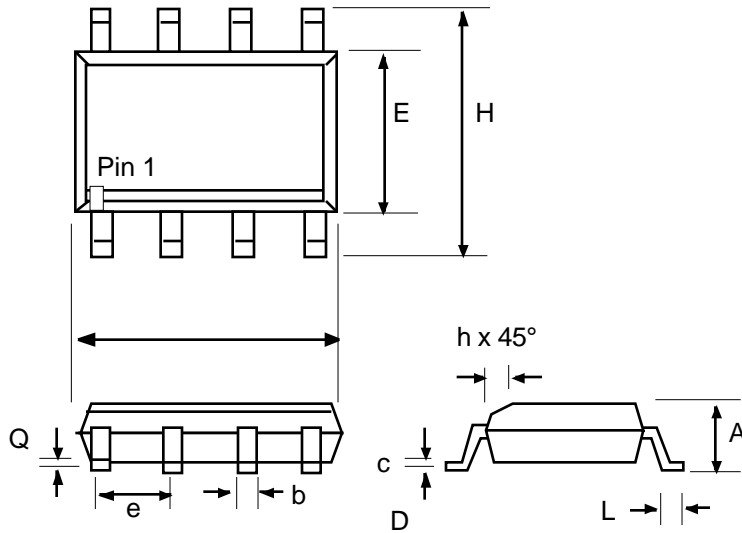

Symbol	Inches		Millimeters	
	Min	Max	Min	Max
A	0.055	0.061	1.397	1.5494
b	0.013	0.019	0.330	0.483
D	0.185	0.200	4.699	5.080
E	0.150	0.160	3.810	4.064
H	0.225	0.245	5.715	6.223
e	.050 BSC		1.27 BSC	
h		0.015		0.381
L	0.016	0.035	0.406	0.889
Q	0.004	0.01	0.102	0.254

Ordering Information

Part/Order Number	Marking	Package	Temperature
MK2712S	MK2712S	8 pin SOIC	0-70°C
MK2712STR	MK2712S	Add tape and reel	0-70°C
MK2712SLF	MK2712SL	8 pin SOIC	0-70°C
MK2712SLFTR	MK2712SL	Add tape and reel	0-70°C

While the information presented herein has been checked for both accuracy and reliability, Integrated Circuit Systems, Inc (ICS) assumes no responsibility for either its use or for the infringement of any patents or other rights of third parties, which would result from its use. No other circuits, patents, or licenses are implied. This product is intended for use in normal commercial applications. Any other applications such as those requiring extended temperature range, high reliability, or other extraordinary environmental requirements are not recommended without additional processing by ICS. ICS reserves the right to change any circuitry or specifications without notice. ICS does not authorize or warrant any ICS product for use in life support devices or critical medical instruments.