

## 阅读申明

- 1.本站收集的数据手册和产品资料都来自互联网，版权归原作者所有。如读者和版权方有任何异议请及时告之，我们将妥善解决。
- 2.本站提供的中文数据手册是英文数据手册的中文翻译，其目的是协助用户阅读，该译文无法自动跟随原稿更新，同时也可能存在翻译上的不当。建议读者以英文原稿为参考以便获得更精准的信息。
- 3.本站提供的产品资料，来自厂商的技术支持或者使用者的心得体会等，其内容可能存在描述上的差异，建议读者做出适当判断。
- 4.如需与我们联系，请发邮件到marketing@iczoom.com，主题请标有“数据手册”字样。

## Read Statement

1. The datasheets and other product information on the site are all from network reference or other public materials, and the copyright belongs to the original author and original published source. If readers and copyright owners have any objections, please contact us and we will deal with it in a timely manner.
2. The Chinese datasheets provided on the website is a Chinese translation of the English datasheets. Its purpose is for reader's learning exchange only and do not involve commercial purposes. The translation cannot be automatically updated with the original manuscript, and there may also be improper translations. Readers are advised to use the English manuscript as a reference for more accurate information.
3. All product information provided on the website refer to solutions from manufacturers' technical support or users the contents may have differences in description, and readers are advised to take the original article as the standard.
4. If you have any questions, please contact us at marketing@iczoom.com and mark the subject with "Datasheets" .

# ASM3P2180A

## Peak Reducing EMI Solution

### Product Description

The ASM3P2180A is a versatile spread spectrum frequency modulator designed specifically for a wide range of clock frequencies. ASM3P2180A reduces electromagnetic interference (EMI) at the clock source, allowing system wide reduction of EMI of down stream clock and data dependent signals. ASM3P2180A allows significant system cost savings by reducing the number of circuit board layers, and shielding that are traditionally required to pass EMI regulations. ASM3P2180A modulates the output of a single PLL in order to “spread” the bandwidth of a synthesized clock, thereby decreasing the peak amplitudes of its harmonics. This results in significantly lower system EMI compared to the typical narrow band signal produced by oscillators and most clock generators. Lowering EMI by increasing a signal’s bandwidth is called spread spectrum clock generation. ASM3P2180A uses the most efficient and optimized modulation profile approved by the FCC and is implemented by using a proprietary all-digital method.

### Features

- Generates a 1x EMI Optimized Clock Output
- Input Frequency:
  - ◆ 6 MHz – 10 MHz
  - ◆ 18 MHz – 30 MHz
- Output Frequency:
  - ◆ 6 MHz – 10 MHz
  - ◆ 18 MHz – 30 MHz
- Two Selectable Down Spread Options
- Selectable Frequency Range
- Integrated Loop Filter Components
- Operates with a 3.3 V Supply
- CMOS Design
- 8-Pin SOIC Packages
- This Device is Pb-Free, Halogen Free and is RoHS Compliant

### Applications

The ASM3P2180A is targeted towards notebook LCD displays, other displays using an LVDS interface, PC peripheral devices and embedded systems.



ON Semiconductor®

[www.onsemi.com](http://www.onsemi.com)



SOIC-8 NB  
CASE 751

### PIN CONNECTION

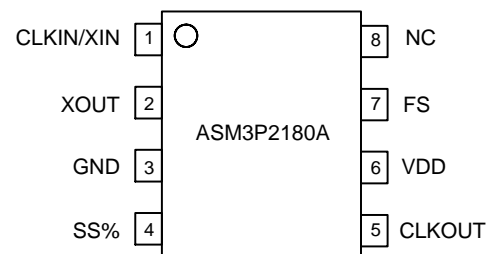

### MARKING DIAGRAM

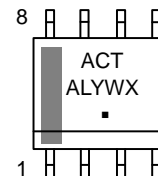

ACT = Specific Device Code  
A = Assembly Location  
L = Wafer Lot  
Y = Year  
W = Work Week  
■ = Pb-Free Package

(Note: Microdot may be in either location)

### ORDERING INFORMATION

See detailed ordering and shipping information on page 4 of this data sheet.

# ASM3P2180A

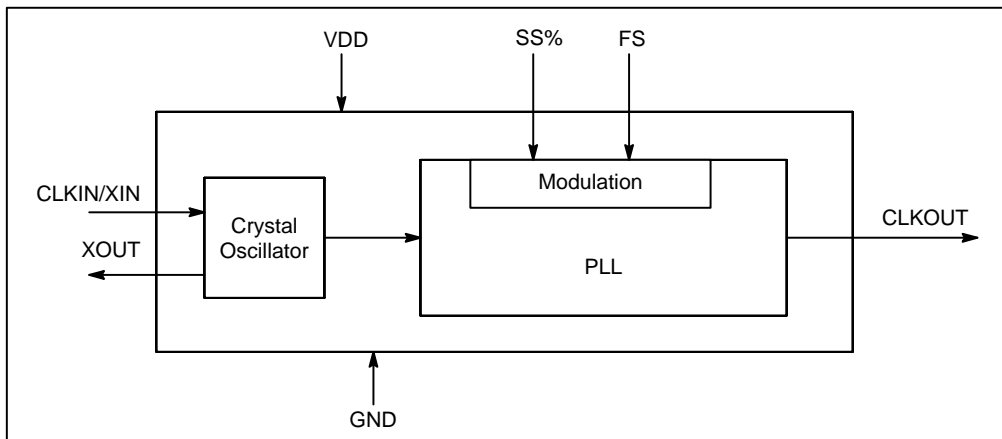

Figure 1. Block Diagram

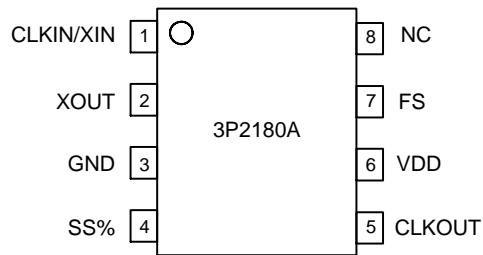

Figure 2. Pin Diagram

Table 1. PIN DESCRIPTION

Pin#	Pin Name	Type	Description
1	CLKIN/XIN	I	Crystal Connection or External Reference Clock Input
2	XOUT	O	Connection for an External Crystal. If using an External Reference, this Pin must be Left Unconnected
3	GND	P	Ground to Entire Chip
4	SS%	I	Spread Selection Input. Has an Internal Pull-Up Resistor
5	CLKOUT	O	Modulated Clock Output
6	VDD	P	Power Supply for the Entire Chip
7	FS	I	Frequency Selection Bit. This Pin Selects the Frequency Range of Operation (See Table 2). Has an Internal Pull-Up Resistor
8	NC	-	No Connect

Table 2. FREQUENCY RANGE SELECTION

FS	Frequency Range (MHz)
0	6–10
1	18–30

# ASM3P2180A

**Table 3. SPREAD SELECTION**

SS%	Frequency (MHz)		Deviation (%) (Typ)
	FS = 0	FS = 1	
0	6	18	-2
	8	24	-1.5
	10	30	-1
1	6	18	-4
	8	24	-3
	10	30	-2

**Table 4. ABSOLUTE MAXIMUM RATINGS**

Symbol	Parameter	Rating	Unit
VDD, VIN	Voltage on any Pin with Respect to Ground	-0.5 to +4.6	V
TSTG	Storage Temperature	-60 to +125	°C
TS	Maximum Soldering Temperature (10 s)	260	°C
TJ	Junction Temperature	150	°C
TDV	Static Discharge Voltage (as per JEDEC STD22-A114-B)	2	kV

Stresses exceeding those listed in the Maximum Ratings table may damage the device. If any of these limits are exceeded, device functionality should not be assumed, damage may occur and reliability may be affected.

**Table 5. RECOMMENDED OPERATING CONDITIONS**

Parameter	Description	Min	Max	Unit
VDD	Supply Voltage	2.8	3.7	V
TA	Operating Temperature (Ambient Temperature)	-40	+85	°C
CL	Load Capacitance	-	15	pF
CIN	Input Capacitance	-	4	pF

Functional operation above the stresses listed in the Recommended Operating Ranges is not implied. Extended exposure to stresses beyond the Recommended Operating Ranges limits may affect device reliability.

**Table 6. DC ELECTRICAL CHARACTERISTICS**

Symbol	Parameter	Min	Typ	Max	Unit
VIL	Input Low Voltage	GND - 0.3	-	0.8	V
VIH	Input High Voltage	2.0	-	VDD + 0.3	V
IIL	Input Low Current (Pull-Up Resistors on Inputs SS%, FS)	-	-	-27	µA
IIH	Input High Current	-	-	18	µA
I <sub>XOL</sub>	X <sub>OUT</sub> Output Low Current (@ 0.4 V, VDD = 3.3 V)	-	3	-	mA
I <sub>XOH</sub>	X <sub>OUT</sub> Output High Current (@ 2.5 V, VDD = 3.3 V)	-	4	-	mA
VOL	Output Low Voltage (VDD = 3.3 V, IOL = 4 mA)	-	-	0.4	V
VOH	Output High Voltage (VDD = 3.3 V, IOH = 4 mA)	2.5	-	-	V
ICC	Dynamic Supply Current Normal Mode (3.3 V and 10 pF Loading)	10	15	25	mA
IDD*	Static Supply Current Standby Mode	-	-	7	mA
VDD	Operating Voltage	2.8	3.3	3.7	V
tON	Power-Up Time (First Locked Clock Cycle after Power-Up)	-	0.18	-	ms
ZOUT	Clock Output Impedance	-	50	-	Ω

\* CLKIN pin pulled to GND.

# ASM3P2180A

**Table 7. AC ELECTRICAL CHARACTERISTICS**

Symbol	Parameter	Min	Typ	Max	Unit
CLKIN	Input Frequency FS = 0 FS = 1	6 18	– –	10 30	MHz
CLKOUT	Output Frequency FS = 0 FS = 1	6 18	– –	10 30	MHz
t <sub>LH</sub> *	Output Rise Time (Measured at 0.8 V to 2.0 V)	1.2	1.3	1.4	ns
t <sub>HL</sub> *	Output Fall Time (Measured at 2.0 V to 0.8 V)	0.8	0.9	1.0	ns
t <sub>JC</sub>	Jitter (Cycle to Cycle)	–	±325	–	ps
t <sub>D</sub>	Output Duty Cycle	45	50	55	%

\* t<sub>LH</sub> and t<sub>HL</sub> are measured into a capacitive load of 15 pF.

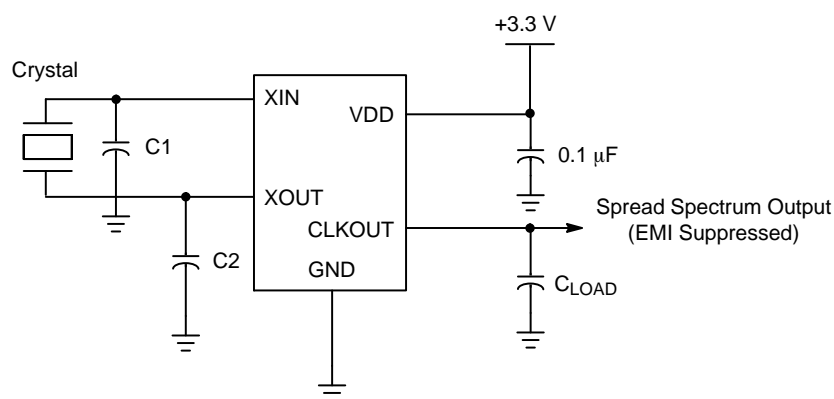

**Figure 3. Typical Test Circuit**

**Table 8. ORDERING INFORMATION**

Part Number	Marking	Package	Temperature	Shipping†
ASM3P2180AF-08SR	ACT	SOIC-8 NB (Pb-Free)	0 to 70°C	2500 / Tape & Reel

†For information on tape and reel specifications, including part orientation and tape sizes, please refer to our Tape and Reel Packaging Specification Brochure, [BRD8011/D](#).

# ASM3P2180A

## PACKAGE DIMENSIONS

### SOIC-8 NB CASE 751-07 ISSUE AK

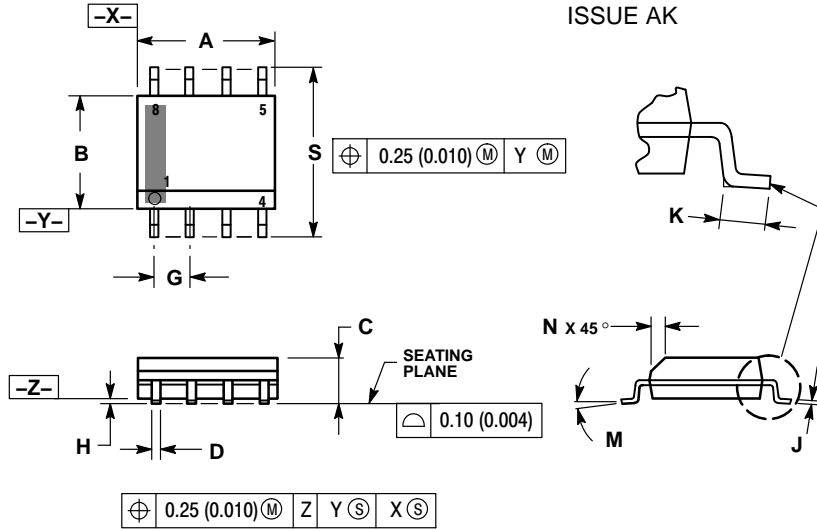

#### NOTES:

1. DIMENSIONING AND TOLERANCING PER ANSI Y14.5M, 1982.
2. CONTROLLING DIMENSION: MILLIMETER.
3. DIMENSION A AND B DO NOT INCLUDE MOLD PROTRUSION.
4. MAXIMUM MOLD PROTRUSION 0.15 (0.006) PER SIDE.
5. DIMENSION D DOES NOT INCLUDE DAMBAR PROTRUSION. ALLOWABLE DAMBAR PROTRUSION SHALL BE 0.127 (0.005) TOTAL IN EXCESS OF THE D DIMENSION AT MAXIMUM MATERIAL CONDITION.
6. 751-01 THRU 751-06 ARE OBSOLETE. NEW STANDARD IS 751-07.

DIM	MILLIMETERS		INCHES	
	MIN	MAX	MIN	MAX
A	4.80	5.00	0.189	0.197
B	3.80	4.00	0.150	0.157
C	1.35	1.75	0.053	0.069
D	0.33	0.51	0.013	0.020
G	1.27 BSC		0.050 BSC	
H	0.10	0.25	0.004	0.010
J	0.19	0.25	0.007	0.010
K	0.40	1.27	0.016	0.050
M	0°	8°	0°	8°
N	0.25	0.50	0.010	0.020
S	5.80	6.20	0.228	0.244

### SOLDERING FOOTPRINT\*

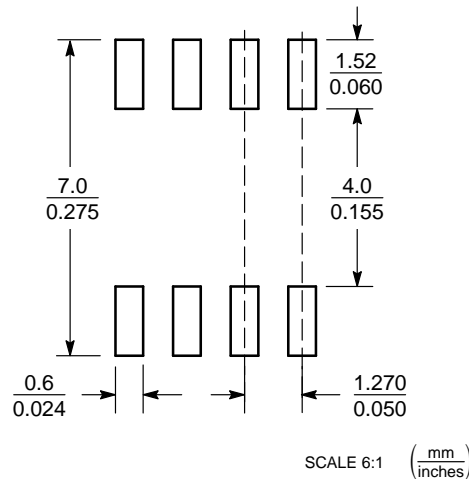

\*For additional information on our Pb-Free strategy and soldering details, please download the ON Semiconductor Soldering and Mounting Techniques Reference Manual, SOLDERRM/D.

ON Semiconductor and are trademarks of Semiconductor Components Industries, LLC dba ON Semiconductor or its subsidiaries in the United States and/or other countries. ON Semiconductor owns the rights to a number of patents, trademarks, copyrights, trade secrets, and other intellectual property. A listing of ON Semiconductor's product/patent coverage may be accessed at [www.onsemi.com/site/pdf/Patent-Marketing.pdf](http://www.onsemi.com/site/pdf/Patent-Marketing.pdf). ON Semiconductor reserves the right to make changes without further notice to any products herein. ON Semiconductor makes no warranty, representation or guarantee regarding the suitability of its products for any particular purpose, nor does ON Semiconductor assume any liability arising out of the application or use of any product or circuit, and specifically disclaims any and all liability, including without limitation special, consequential or incidental damages. Buyer is responsible for its products and applications using ON Semiconductor products, including compliance with all laws, regulations and safety requirements or standards, regardless of any support or applications information provided by ON Semiconductor. "Typical" parameters which may be provided in ON Semiconductor data sheets and/or specifications can and do vary in different applications and actual performance may vary over time. All operating parameters, including "Typicals" must be validated for each customer application by customer's technical experts. ON Semiconductor does not convey any license under its patent rights nor the rights of others. ON Semiconductor products are not designed, intended, or authorized for use as a critical component in life support systems or any FDA Class 3 medical devices or medical devices with a same or similar classification in a foreign jurisdiction or any devices intended for implantation in the human body. Should Buyer purchase or use ON Semiconductor products for any such unintended or unauthorized application, Buyer shall indemnify and hold ON Semiconductor and its officers, employees, subsidiaries, affiliates, and distributors harmless against all claims, costs, damages, and expenses, and reasonable attorney fees arising out of, directly or indirectly, any claim of personal injury or death associated with such unintended or unauthorized use, even if such claim alleges that ON Semiconductor was negligent regarding the design or manufacture of the part. ON Semiconductor is an Equal Opportunity/Affirmative Action Employer. This literature is subject to all applicable copyright laws and is not for resale in any manner.

### PUBLICATION ORDERING INFORMATION

**LITERATURE FULFILLMENT:**  
Literature Distribution Center for ON Semiconductor  
19521 E. 32nd Pkwy, Aurora, Colorado 80011 USA  
**Phone:** 303-675-2175 or 800-344-3860 Toll Free USA/Canada  
**Fax:** 303-675-2176 or 800-344-3867 Toll Free USA/Canada  
**Email:** [orderlit@onsemi.com](mailto:orderlit@onsemi.com)

**N. American Technical Support:** 800-282-9855 Toll Free  
USA/Canada  
**Europe, Middle East and Africa Technical Support:**  
Phone: 421 33 790 2910  
**Japan Customer Focus Center**  
Phone: 81-3-5817-1050

**ON Semiconductor Website:** [www.onsemi.com](http://www.onsemi.com)  
**Order Literature:** <http://www.onsemi.com/orderlit>

For additional information, please contact your local Sales Representative